

# POPULAR MECHANICS

## MAGAZINE

WRITTEN SO YOU CAN UNDERSTAND IT

**Special  
AUTO  
SECTION**



*John Fitch and Phil Walters tell about  
the WORLD'S GREAT ROAD RACES*

**46 PAGES ABOUT  
AUTOMOBILES** including...

- Parade of the '54 Models
- What Car Owners Want Next
- How to Buy a Used Car
- What Makes a Car Run

8-Page **COLOR ALBUM**  
of the Finest American  
Classic Cars

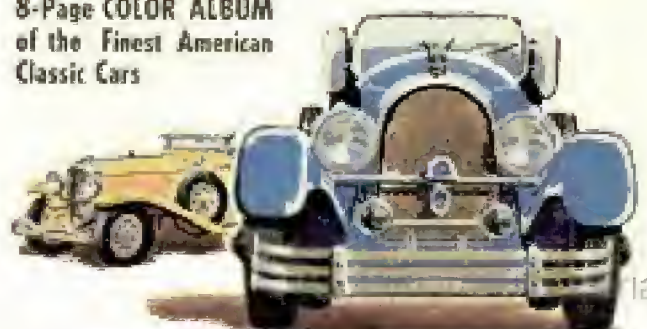

Recognize 1954's new "faces"?—See page 154

# NOW! PUSH-BUTTON POWER!



ELECTRIC STARTING SEA-HORSE 25

- **Electric Starting!**  
(ALSO EQUIPPED FOR MANUAL STARTING)
- **25 Horsepower!**
- **Speeds Over 30 mph!**
- **Fitted for Ship-Master Remote Control!**
- **Gear Shift!** FORWARD-NEUTRAL-REVERSE
- **Mile-Master Fuel System**  
(6 GALLON)
- **Twist-Grip Speed Control**



**FREE!** Write for the new Sea-Horse Catalog. Complete details on the 5 great motors of the 1954 Johnson line—including the revolutionary quiet Sea-Horse 5½ and the flashing, newly-styled Sea-Horse 10. Your copy sent free.

**JOHNSON MOTORS,**  
400 Pershing Road, Waukegan, Illinois  
In Canada: Mtd. by Johnson Motors, Peterborough

**Johnson**  
**SEA-HORSES**  
FOR **DEPENDABILITY**

Here is the last word in sheer outboard luxury—*push-button starting!* The new Electric Starting Sea-Horse 25 is a complete unit (except for battery) ready to spin into action at the touch of your finger. With Ship-Master Remote Control for shift and throttle (Johnson accessory), you now have concentrated command of power at your steering wheel. Choke, start, shift, throttle, steer from any seat in your boat! . . . See your Johnson Dealer. Look for his name under "Outboard Motors" in your classified telephone directory.

#### THE NEW 1954 SEA-HORSES

- SEA-HORSE 5½—5½ hp. Johnson's new "Suspension Drive" sensation. It's quiet! . . . \$210.00\*
- ELECTRIC STARTING SEA-HORSE 25—25 hp. . . . . \$498.00\*
- SEA-HORSE 25—25 hp. Speeds over 30 mph! With 6-gal. Mile-Master Fuel System. Gear Shift. Twist-Grip. Only . . . \$410.00\*
- SEA-HORSE 10—10 hp. Power, speed and terrific "getaway." With Mile-Master Fuel System. Gear Shift. Twist-Grip Speed Control. Outboard motoring's great buy . . . . . \$297.50\*
- SEA-HORSE 3—3 hp. 32-lb. twin / Angle-matic Drive. . . \$145.00\*

\*F.O.B. factory, subject to change. Weight approx. OBC certified brake hp at 4000 rpm.



**Never  
needs  
waxing!**

**"We installed it ourselves — and look!  
ALL THROUGH IN TIME FOR SUPPER!"**

**J**EANNE and I had heard about the wonders of Goodyear VINYL-TILE flooring, and decided to take a try at installing it ourselves in our kitchen.

So on Saturday morning we went to work, and we were all through by early afternoon!

But Jeanne deserves the credit, for she was the one who stopped by the dealer's and picked up the handy, home installation kit and the "How To Install" folder put out by Goodyear.

After that, it was simple (except she did have trouble making up her mind about which of the 18 beautiful VINYL-TILE colors to use!).

And it's simpler still to keep VINYL-TILE clean and sparkling. You see, it is specially pre-polished at the factory to a natural, lasting luster.

A swish of a sudsy mop does the trick—we've found it unnecessary to wax it ever!

P.S. Goodyear VINYL-TILE comes in tiles and yard-wide rolls—flexes easily, is ideal for counter tops and contour coving. SEND FOR FREE VINYL-TILE "SELF INSTALLATION" BOOKLET—address a postcard to: Goodyear, Flooring Dept. N-8318, Akron 16, Ohio.



**FLOR-MASTER INSTALLATION KIT** provides the simple tools required to do a professional job in jig time. Available at all better dealers' — where Goodyear VINYL-TILE is sure to be a featured item.

**GOODYEAR Vinyl-Tile**

**FLOORING, COUNTER TOPS, WALLS—BY THE YARD OR TILE**

Flor-Master—T. M. The Goodyear Tire & Rubber Company, Akron, Ohio

# What you can learn from the airlines about **CHAMPION** Spark Plugs for YOUR CAR!



ALL OF THESE AIRLINES  
ARE CHAMPION USERS

Allegheny Airlines  
 American Airlines  
 Braniff International Airways, Inc.  
 California Central Airlines  
 Capital Airlines  
 Central Airlines  
 Colonial Airlines  
 Continental Air Lines  
 Delta-C & S. Air Lines, Inc.  
 Eastern Air Lines  
 Flying Tiger Line  
 Frontier Airlines  
 Maritime Central Airways  
 National Airlines  
 North Central Airlines  
 Northeast Airlines  
 Northwest Airlines, Inc.  
 Pacific Northern Airlines  
 Pan American-Grace Airways, Inc.  
 Pan American World Airways, Inc.  
 Piedmont Airlines  
 Pioneer Air Lines  
 Silek Airways  
 Southern Airways  
 Southwest Airways  
 Trans-Canada Airlines  
 Trans-Texas Airways  
 Trans-World Airlines, Inc.  
 United Air Lines  
 West Coast Airlines  
 Western Air Lines  
 Iberia  
 Sabena  
 Swissair  
 Air France  
 Iranian Airways  
 Air Ceylon Limited  
 Israel Airlines, Ltd.  
 KLM Royal Dutch Airlines  
 Compania de Aviacion "Foucart" S.A.  
 British Commonwealth Pacific Airlines  
 Braathens South-American &  
     Far East Airtransport  
 Scandinavian Airlines System  
 Servicos Aereos Cruzeiro Do Sul, Ltda.  
 Linea Aeropostal Venezolana  
 Canadian Pacific Airlines, Ltd.  
 Caribbean-Atlantic Airlines, Inc.  
 Linea Aerea Italiana S.P.A.  
 Lloyd Aereo Boliviano S.A.  
 Aerovias Guent, S.A.  
 National Greek Airlines  
 Orient Airways Ltd.  
 Trans-Australia Airlines  
 Turkish State Airlines  
 Aerolineas Argentinas  
 Air-India International, Ltd.  
 Air-India, Ltd.  
 Philippine Airlines  
 Hawaiian Airlines Limited  
 Aerovias de Mexico, S.A.  
 Panair do Brasil, S.A.  
 Airways (India) Ltd.  
 CAT Incorporated  
 Aer Lingus  
 Aero O/Y Air Services of India, Ltd.  
 Cathay Pacific Airways, Ltd.  
 South African Airways  
 Ethiopian Airlines, Inc.  
 Compagnie Air Algeris  
 Garuda Indonesian Airways N.V.  
 Transportes Aereos Mexicanos, S.A.  
 Union Aeronautique de Transport  
 Flugfelag Islands, H.F.  
 Air Tahiti  
 Qantas Empire Airways, Ltd.  
 Aerovias Nacionales de Colombia  
 Aerovias Venezolanas, S.A.  
 Compania Cubana de Aviacion, S.A.  
 Lineas Aereas Unidas, S.A.  
 Serv. Aereos de Chiapas, S.A.  
 Transp. Aereos de Yajalon, S.A.  
 Companhia Itau de Transportes Aereos  
 Empresa de Transportes Aerovias Brasil  
 Laida Aerea Nacional S/A  
 Real S/A-Transportes Aereos  
 Transportes Aereos Nacional Ltda.  
 Viacao Aerea Sao Paulo, S/A  
 Societe des Transports Aeriens de  
     L'Extreme Orient (Cosara)  
 Bharat Airways Ltd.  
 Deccan Airways Ltd.  
 Aerovias Reforma, S.A.  
 Thai Airways Co., Ltd.  
 Central African Airways Corp.  
 Cia. Mexicana de Aviacion, S.A.  
 Aerolinee Italiane Internazionali (Alitalia)

Here's why the selection of Champion Spark Plugs by every major airlines is important to you.

They buy Champions because the airlines' own laboratory and flight tests prove Champions superior to all other aviation spark plugs. The same engineering, research and manufacturing skills that produce the world's best aircraft spark plugs produce the Champion Spark Plugs for your car.

That's why when you buy Champions you get spark plugs that combine peak performance and top dependability with maximum operating economy.

See your nearby garage or service station for Champions specially engineered for your car.



GET DEPENDABLE

## CHAMPION

SPARK PLUGS



# Popular Mechanics Magazine

Registered in U. S. Patent Office and Canada

H. H. WINDSOR, Founder

H. H. WINDSOR, JR., Editor and Publisher



## this month's cover

THAT'S A SUNBEAM ALPINE hurtling along a mountain road on our cover, and at the wheel is John Fitch, America's best-known sports-car racing driver. Fitch is the only American ever to win the coveted Coupe des Alpes in the Alpine Rally. In a special PM interview on page 178, he and Phil Walters, his teammate, give a fascinating picture of the great road races of the world. They describe Le Mans, Mille Miglia, the Tourist Trophy, the Mexican Road Race and all the other famous open and closed circuits. And they name the course which is the most challenging of all to the world's best drivers. This is just one of many auto stories in the special section which starts on page 144. You'll find a colorful album of the finest American classic cars and a "Report to Detroit" by the car owners, who turn designers themselves to tell the makers what they want

Published monthly by Popular Mechanics Company, 200 E. Ontario St., Chicago 11, Ill. H. H. Windsor, Jr., President; Wm. Harrison Strauss, exec. vice-pres.; H. F. Windsor, vice-president and secretary-treasurer; H. H. Windsor III, vice-president; Clover L. Perkins, advertising manager; Alan M. Deane, circulation manager. Single copy in the United States and Canada, 35 cents; elsewhere, 45 cents. In the United States and possessions, Canada, Philippines and countries of the Pan-American Postal Union, 1 year \$3.50; 2 years, \$6.00; 3 years \$8.00. To all other countries add \$1.00 a year over United States prices for overseas postage. If you plan to move, notify us at least 30 days in advance so you will not miss an issue. Give both your old and new addresses. Entered as Second Class Matter, September 15, 1903, at the Post Office at Chicago, Illinois, under Act of March 3, 1879. Entered as Second Class Matter at Post Office Dept., Canada. Registered as Second Class Matter at the Post Office at Mexico, D. F., Mexico, June 20, 1950. Copyright 1953 by Popular Mechanics Company. Copyright under International Copyright Union. Copyright in France. All rights reserved under Pan-American Copyright Union. Printed in the United States of America.

Volume 101

FEBRUARY 1954

Number 2

Address all communications to:  
200 East Ontario Street, Chicago 11, Illinois

Managing Editor.....Roderick M. Grant  
Assistant Managing Editor.....Wayne Whittaker  
Shop Notes and Crafts Editor.....James R. Ward  
Radio-Television, Electronics Editor.....Frank L. Brittin  
Associate Editor, Aviation.....Aubrey O. Cookman, Jr.  
Associate Editor.....Clifford B. Hicks  
Associate Editor, Automotive.....Arthur R. Railton  
Associate Editor, Shop Notes and Crafts.....Wayne C. Leckay  
Assistant Editor, Shop Notes.....W. Clyde Lamney  
Assistant Editor, Crafts.....Frank N. Stephany  
Assistant Editor, Makeup.....John C. Dalen  
Automotive Correspondent.....Leo Donovan  
Art Director.....Frank Beatty

### Assistant Editors

Leonard F. Hiltz                      Jay W. Hedden                      Elliott H. McCleary  
Eastern Editor.....Richard F. Dampewolff  
Empire State Bldg., Room 2906, New York City 1  
Western Editor.....Thomas E. Stimson, Jr.  
London Manager.....Douglas W. Wedderspoon  
Eagle House, Jermyn St., London S. W. 1, England  
Director, Bureau of Information.....Allan Carpenter  
200 E. Ontario St., Chicago 11

## IN THIS ISSUE

<u>Guided Missiles on Leash</u> - - - - -	<u>97</u>
<u>Mr. Peepers Does His Homework</u> - - - - -	<u>110</u>
<u>The Iron Road to Labrador</u> - - - - -	<u>118</u>
<u>Do It With Staples</u> - - - - -	<u>128</u>
<u>TV Joins the Air Force</u> - - - - -	<u>134</u>
<b>Special Auto Section—</b>	
<u>The Twelve Finest American Classics</u> - - - - -	<u>144</u>
<u>Parade of New Cars</u> - - - - -	<u>154</u>
<u>What's New in '54</u> - - - - -	<u>164</u>
<u>Report to Detroit</u> - - - - -	<u>168</u>
<u>What Makes Your Car Run?</u> - - - - -	<u>174</u>
<u>The Great Road Races of the World</u> - - - - -	<u>178</u>

## For the Craftsman

<u>3 Sewing Cabinets From Single Design</u> - - - - -	<u>185</u>
<u>Pull Toy in Eight Models</u> - - - - -	<u>191</u>
<u>Salving Home Problems</u> - - - - -	<u>196</u>
<u>Buy Your Boat in a Package</u> - - - - -	<u>205</u>
<u>Make a Model of the Midway—Part II</u> - - - - -	<u>212</u>
<u>How to Buy a Used Car</u> - - - - -	<u>222</u>
<u>Tips on Buying Used Electric Motors</u> - - - - -	<u>229</u>
<u>Know Your Metal Shaper</u> - - - - -	<u>234</u>
<u>Radio, TV and Electronics</u> - - - - -	<u>245</u>

Other items, and manufacturers of available products described, are listed on pages 16, 20 and 22



*This 1951 Nash is typical of many fine, low-priced used cars on Nash dealers' lots right now!*

*Why are Nash cars more economical to run? Every Nash has a sealed-in Iso-Thermal Intake Manifold, and high compression to deliver more power on less gasoline, under all conditions. Every Nash engine has the vibration-free smoothness of a counterbalanced crankshaft. And every Nash engine today has a special oil-controlling ring employing a new principle to give low oil consumption over thousands of miles.*



***The car with the "Double Lifetime"***

Drive your Nash as long as you want—as far as you like . . . you probably will never use up the reservoir of service—the "DOUBLE LIFETIME" that was built into it originally. That means, of course, it will be worth more when you sell it—you'll be money ahead when you pass it along to the next owner.

***How exclusive Nash features  
Double your Travel Pleasure***

Now let's forget the dollars and cents you save—and think about the pleasure you gain when you buy a used Nash.

You'll get extra room for passengers and luggage to make traveling so much more enjoyable.

Most Nash used cars have the famous Weather Eye Conditioned Air heating and ventilating system—and built-in beds for overnight sleeping!

So when you are looking for a good used car, remember these facts about Nash "DOUBLE LIFETIME" Value. You'll treat yourself to the finest buy you ever had in an automobile!



***Nash*** *The Car With The Double Lifetime  
... Built to Stay New Longer*



**SEE A NASH DEALER FOR THE  
BEST USED CAR "BUY" IN TOWN**

*Nash Motors, Division Nash-Kelvinator Corporation, Detroit, Mich.*

# USED CAR BUYERS!

Here's New Proof That Nash—  
*The "Car with the Double Lifetime"*  
—Is the Best Used Car You Can Buy!

---

**I**T JUST makes good common sense that the more quality and durability built into a new car originally, the more good miles you'll get from it as a used car. And Nash is the car with the "DOUBLE LIFETIME" built in—built to last twice as long as the average automobile—as so many owners will testify.

Read these paragraphs from a letter by enthusiastic Nash owner, Clyde H. Andrist, of Fort Collins, Colorado:

*"I have had extremely fine service from all my Nash cars . . . drove a 1941 Nash Ambassador 256,000 miles and had only one motor overhaul. Drove a 1948 Ambassador 89,000 miles and had no work done on it at all. Traded it in on a '49 Nash which still looked and performed like new at 134,000 miles when I again traded—for a new Nash.*

*"My cars are subject to hard usage . . . averaging 60 miles per hour on long drives . . . I still average better than 22 miles per gallon and never add oil between changes . . . on all kinds of roads . . . plowing through heavy mud or deep snow . . . in temperatures as low as 54° below zero and up to 118°."* Think of it—134,000 miles on a '49 Nash Ambassador—and it still *runs like new—and looked like new!*

## **What this means to Used Car Buyers**

When you buy a used Nash, you can look

forward to more wonderful miles than you ever dreamed a car would deliver.

Because that's the way every Nash is built—built to give a "DOUBLE LIFETIME" of care-free motoring.

*Why do Nash cars last longer?* Because of exclusive Nash Airflyte Construction!

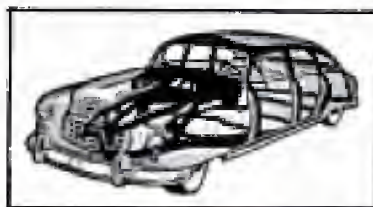

Instead of the ordinary body bolted to a frame, the structure of every Nash is a solid, welded

unit. There are no body bolts to loosen, rattle or squeak. It is twice as rigid, stronger and safer—stays new years longer.

*Why do Nash cars seldom need repainting?*

Unlike other car-makers that use quick-drying

lacquers, Nash employs specially formulated enamels baked to a hard, porcelain-like finish. This durable finish is



"anchored" to sheet metal completely treated with the famous Bonderite rust-proofing process to resist aging, cracking, rusting—to stay beautiful years longer.

THIS ONE



PHOK-GHK-WZQH

Copyrighted material

## Animals Protect Themselves



Normally of a very timid nature, a Doe will fight ferociously and effectively

to protect its fawn against attacks of Rattlesnakes and other natural enemies.

### **AC ALUVAC PROTECTS MORE NEW CAR ENGINES THAN ANY OTHER BRAND**

Every car engine has its natural enemies too—the dust, dirt, grit and sludge that collect in motor oil—ready to attack smooth-surfaced bearings, pistons and other precision parts.

AC's Aluvac Element provides proved protection against these engine oil enemies. Its special accordion fold gives ten times the filtering area of ordinary elements, and its specially formulated filtering material screens out particles as fine as 1/100,000 of an inch.

Change your oil filter element at from 4000 to 6000 miles—and change to AC Aluvac to make your car's engine run better, longer.



WITH  
**ALUVAC**  
ELEMENTS



AC SPARK PLUG DIVISION

GENERAL MOTORS CORPORATION

in this corner.....

## THE EDITORS



FOR THE PIN-UP photographs of the great American Classic cars which we bring you in the color pages that open the special automobile section in this issue, our staff photographer and automobile editor traveled hundreds of miles.

The Classics they sought were found in family garages from California to New



England. The 1931 Duesenberg roadster, which was acclaimed as the greatest American Classic, is owned by William S. McKelvy of Pittsburgh, Pa., but Associate Editor Art Railton (shown lending a muscle at the rear fender) and Photographer Don Honick (who took this picture) found the Duesenberg in Jim Hoe's garage, seven miles off in the woods from Westport, Conn. At the moment it was undergoing an engine overhaul. Hoe is probably the nation's outstanding Duesenberg mechanic, and his garage was filled with Duesenbergs in various phases of repair. Hoe, incidentally, has a Duesenberg of his own which he races—and usually brings in a winner.

### **To the Editor:**

What can be done to decrease the number of traffic violations on our streets and highways? We are firmly convinced that radar speed-control techniques can help in cutting down the number of violators of speed regulations and thereby reduce accidents.

Members of the staff of our Center for Safety Education at New York University have completed a 16-week study using radar in 11 eastern states from Maine to Maryland. This has involved hundreds of speed checks both within city limits and on rural highways. These studies were conducted at the invitation of state traffic authorities. On some highways we were

(Continued to page 10)



# This **FREE SAMPLE LESSON** will prove you can become an expert **BOOKKEEPER... ACCOUNTANT** **OR C.P.A.**

This well-paid  
LaSalle-trained  
Accountant's  
success could  
be yours.



## FREE SAMPLE LESSON

We offer you this free sample lesson so that you can prove to yourself that you CAN master Accountancy—quickly, thoroughly—in spare time at home.

You will see exactly how LaSalle's famous "Problem Method" works... how you are led step-by-step through actual accounting work—learning by doing and not by study of theory alone. First you tackle easy problems, then more difficult ones—until soon you master them all. And at every step you have the close personal guidance of LaSalle's large staff of C.P.A. instructors.

## HIGHER ACCOUNTANCY

By the LaSalle Problem Method..

### Practical Accounting

Assignment 1

THE BALANCE SHEET



**QUESTIONS** from the "Journal of Accountancy" on the subject of the "Practical Accounting" of the "Higher Accountancy" course of the LaSalle Extension University.

The accounting profession is probably the best paid in the world. It has few professions to which the average person is admitted to membership. It is not known to all.

There is a need for accountants. There is ample opportunity for advancement. There is no prospect that the supply will ever exceed the demand within the limits of our country.

LaSalle Extension University  
A Correspondence Institution  
CHICAGO

**THIS SAME LESSON HAS STARTED HUNDREDS OF THOUSANDS** toward well-paid accounting careers—in business, government, and as C.P.A.'s. Even without previous knowledge, progress is rapid—earning power climbs fast. This sample lesson shows why.

**I**f you have been envying the high incomes and good jobs enjoyed by thousands of men and women Accountants today... incomes ranging from \$4,000 to \$10,000 and more per year... why not launch such a career for yourself?

Do you doubt that you can?

Then let us send you—without cost or obligation—the same Lesson Number One with which LaSalle has started several hundred thousand

men and women toward successful accounting careers. We want you to see for yourself how this remarkable method, originated by LaSalle, makes Accountancy simple, interesting, practical, and certain... how it leads you step-by-step to a complete mastery of Accounting—and on up to the coveted degree of Certified Public Accountant if you so aspire.

It doesn't matter whether you've had previous bookkeeping experience, or whether you don't know a debit from a credit. Whether you wish to qualify as an expert bookkeeper, advanced accountant, cost accountant, auditor, government accountant, income tax specialist, or public accountant... you'll find in LaSalle's Problem Method the exact plan to prepare you rapidly and inexpensively—in spare hours at home—without losing a day from your present job.

So right now, today... if you are an adult, employed, and earnestly ambitious for rapid advancement in this highest-paying of all professions... send your name and address on the coupon below. We'll send the free sample lesson—plus our 48-page book outlining today's career opportunities and how you can qualify for them. A coupon like this has started many thousands toward greater success. It can do the same for you. Mail it today!

### Clip Coupon... Mail TODAY!

LaSalle Extension University... A Correspondence Institution

Dept. 264H, 417 S. Dearborn Street, Chicago 5, Illinois

YES, I want to see how LaSalle's "Problem Method" works... how I can qualify for high-pay Accountancy positions. Send Free Sample Lesson—also your 48-page book, "Accountancy, the Profession That Pays"....all without cost or obligation.

Name.....Age.....

Street Address.....

City, Zone & State.....

Present Position.....



**Nearly 10%  
of all C.P.A.'s  
in the U.S. have  
been trained by the  
LaSalle Problem  
Method**

## GOOD-PAY JOBS IN 5 BIG FIELDS

If you were an expert accountant right now, chances are you would find yourself among the highest-paid of all professional men and women. Surveys show that accountants earn more than those in other major professions.

There are five big fields of opportunity open to Accountancy-trained men and women... opportunities that are wide open and highly inviting, offering maximum income and job security in good times or bad. And under LaSalle's "Problem Method" you can start earning while still learning—either in spare-time or full-time employment... or in business for yourself with no capital required.

Get the latest information by sending for our 48-page book, "Accountancy, the Profession That Pays"... plus free sample lesson. The coupon at right will bring both to you without cost or obligation. LaSalle Extension, 417 S. Dearborn St., Chicago 5, Ill.

# Here's proof you can



*Here are the results of a recent survey conducted by I.C.S.—a sheaf of reports from I.C.S. 10-year graduates and non-graduates. This group alone shows an average pay increase of 103%. You can match this!*

"Thanks to I.C.S., I've been able to increase my income 250%."

"I was making \$65 a week when I enrolled. Now making over \$100."

"I.C.S. course in Mechanical Drafting made it possible for me to get a better job at twice my former pay."

"If it weren't for I.C.S., I'd still be back in the '35 a week class."

"I consider my enrollment with I.C.S. the most important step in my career."



Just imagine what you could do with twice your present income. While you're still young, you could enjoy a standard of living usually associated with success . . . \$65 suits . . . an \$18,000 home . . . security for your family . . . new respect from your friends.

If you're like the average I.C.S. graduate surveyed, you'll *actually be making twice your present income within 10 years.*

**From \$2,514.63 to \$5,114.84**

This is the jump made by the average I.C.S. student over a 10-year period.

**Get Expert Guidance with 2 FREE BOOKS.** By return mail, you get complete catalog on the career you check. Also 40-page pocket-size guide, "How to Succeed," Both FREE! Just mark the coupon.



Average increase — 103%. You can expect I.C.S. to double *your* present salary *if you are an average student.* With a little extra effort, you can be even better off!

#### **277 success-tested subjects**

I.C.S. courses cover practical subjects in a practical way. You use your spare time—time that others waste—to acquire knowledge worth thousands of dollars to business and industry.

If you want to be twice as well off in just a few years as you are today, mark and mail the coupon at right.

**NOTE:** The average man or woman will put off mailing this coupon till later. Consider yourself above average, with a better-than-average chance of doubling your income, if you mail the coupon now.

# double your income

What's your income rating?

Returns from 21 states . . . from accountants, draftsmen, engineers, technicians . . . show the following important facts about your expected income over a 10-year period.

	Age 30	Age 40	% Increase
Average income for all U. S. men	\$3,288.00	\$3,617.00	10%
Average income for college graduates (men)	\$4,227.00	\$5,142.00	20%
Average income for 41 I. C. S. graduates and non-graduates surveyed, Jan. '53	\$2,514.63 before I. C. S. training	\$5,114.84 as of Jan. '53	103%

Source: 1950 Census

I. C. S., Scranton 9, Penna.

## INTERNATIONAL CORRESPONDENCE SCHOOLS

ICS

BOX 5611-L, SCRANTON 9, PENNA.

Without cost or obligation, send me "HOW to SUCCEED" and the booklet about the course BEFORE which I have marked X:

- |   |  |   |  |   |
|---|--|---|--|---|
| <p><b>ART</b></p> <input type="checkbox"/> Commercial Art<br><input type="checkbox"/> Magazine Illustrating<br><input type="checkbox"/> Fashion Illustrating<br><input type="checkbox"/> Cartooning<br><input type="checkbox"/> Sketching and Painting<br><input type="checkbox"/> Show Card and Sign Lettering <p><b>AUTOMOTIVE</b></p> <input type="checkbox"/> Automobile Mechanic<br><input type="checkbox"/> Auto Elec. Technician<br><input type="checkbox"/> Auto Body Rebuilding and Refinishing<br><input type="checkbox"/> Diesel-Gas Engines <p><b>AVIATION</b></p> <input type="checkbox"/> Aeronautical Engineering Jr.<br><input type="checkbox"/> Aircraft Engine Mechanic<br><input type="checkbox"/> Airplane Drafting <p><b>BUILDING</b></p> <input type="checkbox"/> Architecture<br><input type="checkbox"/> Arch. Drafting<br><input type="checkbox"/> Building Contractor<br><input type="checkbox"/> Estimating<br><input type="checkbox"/> Carpenter and Mill Work<br><input type="checkbox"/> Carpenter Foreman<br><input type="checkbox"/> Reading Blueprints<br><input type="checkbox"/> House Planning<br><input type="checkbox"/> Plumbing | <p><input type="checkbox"/> Heating<br/> <input type="checkbox"/> Painting Contractor<br/> <input type="checkbox"/> Air Conditioning<br/> <input type="checkbox"/> Electrician</p> <p><b>BUSINESS</b></p> <input type="checkbox"/> Business Administration<br><input type="checkbox"/> Certified Public Accountant<br><input type="checkbox"/> Bookkeeping and Accounting<br><input type="checkbox"/> Office Management<br><input type="checkbox"/> Stenography and Typing<br><input type="checkbox"/> Secretarial<br><input type="checkbox"/> Federal Tax<br><input type="checkbox"/> Business Correspondence<br><input type="checkbox"/> Letter-Writing Improvement<br><input type="checkbox"/> Personnel and Labor Relations<br><input type="checkbox"/> Advertising<br><input type="checkbox"/> Retail Business Management<br><input type="checkbox"/> Managing Small Business<br><input type="checkbox"/> Ocean Navigation<br><input type="checkbox"/> Sales Management<br><input type="checkbox"/> Short Story Writing<br><input type="checkbox"/> Creative Salesmanship<br><input type="checkbox"/> Traffic Management <p><b>CHEMISTRY</b></p> <input type="checkbox"/> Chemical Engineering<br><input type="checkbox"/> Chemistry<br><input type="checkbox"/> Analytical Chemistry | <p><input type="checkbox"/> Petroleum—Nat'l Gas<br/> <input type="checkbox"/> Pulp and Paper Making<br/> <input type="checkbox"/> Plastics</p> <p><b>CIVIL, STRUCTURAL ENGINEERING</b></p> <input type="checkbox"/> Civil Engineering<br><input type="checkbox"/> Structural Engineering<br><input type="checkbox"/> Surveying and Mapping<br><input type="checkbox"/> Structural Drafting<br><input type="checkbox"/> Highway Engineering<br><input type="checkbox"/> Reading Blueprints<br><input type="checkbox"/> Construction Engineering<br><input type="checkbox"/> Sanitary Engineering <p><b>DRAFTING</b></p> <input type="checkbox"/> Aircraft Drafting<br><input type="checkbox"/> Architectural Drafting<br><input type="checkbox"/> Electrical Drafting<br><input type="checkbox"/> Mechanical Drafting<br><input type="checkbox"/> Structural Drafting<br><input type="checkbox"/> Sheet Metal Drafting<br><input type="checkbox"/> Ship Drafting<br><input type="checkbox"/> Mine Surveying and Drafting <p><b>ELECTRICAL</b></p> <input type="checkbox"/> Electrical Engineering<br><input type="checkbox"/> Electrician<br><input type="checkbox"/> Electrical Maintenance | <p><input type="checkbox"/> Electrical Drafting<br/> <input type="checkbox"/> Electric Power and Light<br/> <input type="checkbox"/> Lineman</p> <p><b>HIGH SCHOOL</b></p> <input type="checkbox"/> High School Subjects<br><input type="checkbox"/> Mathematics<br><input type="checkbox"/> Commercial<br><input type="checkbox"/> Good English <p><b>MECHANICAL AND SHOP</b></p> <input type="checkbox"/> Mechanical Engineering<br><input type="checkbox"/> Industrial Engineering<br><input type="checkbox"/> Industrial Supervision<br><input type="checkbox"/> Foremanship<br><input type="checkbox"/> Mechanical Drafting<br><input type="checkbox"/> Machine Design-Drafting<br><input type="checkbox"/> Machine Shop Practice<br><input type="checkbox"/> Tool Design<br><input type="checkbox"/> Industrial Instrumentation<br><input type="checkbox"/> Machine Shop Inspection<br><input type="checkbox"/> Reading Blueprints<br><input type="checkbox"/> Toolmaking<br><input type="checkbox"/> Gas-Electric Welding<br><input type="checkbox"/> Heat Treatment—Metallurgy<br><input type="checkbox"/> Sheet Metal Work<br><input type="checkbox"/> Sheet Metal Pattern Drafting<br><input type="checkbox"/> Refrigeration | <p><b>POWER</b></p> <input type="checkbox"/> Combustion Engineering<br><input type="checkbox"/> Diesel—Electric<br><input type="checkbox"/> Electric Light and Power<br><input type="checkbox"/> Stationary Steam Engineering<br><input type="checkbox"/> Stationary Fireman <p><b>RADIO, TELEVISION COMMUNICATIONS</b></p> <input type="checkbox"/> Practical Radio—TV Eng'ing<br><input type="checkbox"/> Radio Operating<br><input type="checkbox"/> Radio and TV Servicing<br><input type="checkbox"/> Television—Technician<br><input type="checkbox"/> Electronics<br><input type="checkbox"/> Telephone Work <p><b>RAILROAD</b></p> <input type="checkbox"/> Locomotive Engineer<br><input type="checkbox"/> Diesel Locomotive<br><input type="checkbox"/> Air Brakes <input type="checkbox"/> Car Inspector<br><input type="checkbox"/> Railroad Administration <p><b>TEXTILE</b></p> <input type="checkbox"/> Textile Engineering<br><input type="checkbox"/> Cotton, Rayon, Woolen Mfg.<br><input type="checkbox"/> Carding and Spinning<br><input type="checkbox"/> Weaving and Weaving<br><input type="checkbox"/> Loom Fixing <input type="checkbox"/> Throwing<br><input type="checkbox"/> Finishing and Dyeing<br><input type="checkbox"/> Textile Designing |
|---|--|---|--|---|

Name \_\_\_\_\_ Age \_\_\_\_\_ Home Address \_\_\_\_\_

City \_\_\_\_\_ Zone \_\_\_\_\_ State \_\_\_\_\_ Working Hours \_\_\_\_\_ A.M. to P.M. \_\_\_\_\_

Occupation \_\_\_\_\_

Canadian residents send coupon to International Correspondence Schools Canadian, Ltd., Montreal, Canada. . . . Special tuition rates to members of the U. S. Armed Forces.

# DRAFTSMEN



**EARN  
BIG MONEY!**

Want more money? Steady employment? Clean, interesting work? Look into Drafting. You'll quickly see why there's real opportunity, more money in this prosperous professional-type work. Want ads show trained draftsmen are in great demand. Find out how you can qualify in a few months for a good job in Drafting.

**LEARN IN SPARE TIME—AT HOME  
(or at the College in Chicago)**

A few hours of pleasant home study every week—that's all. All the tools you need to train at home; valuable drawing outfit included. For 50 years this nationally famous school has prepared men quickly for good positions in industry.

**FREE INFORMATION—SEND COUPON**

Find out how C.T.C. practical training has boosted the pay for hundreds, what it can do for you. Learn what Chicago Tech graduates say about their work, earnings, success. Don't wait! Investigate now. Send for this **FREE TRIAL LESSON**. No charge for this lesson, now or later. Fill out and mail coupon or send post card today.



## CHICAGO TECHNICAL COLLEGE

8-252 Tech Bldg., 2000 So. Michigan Ave.,  
Chicago 16, Illinois

Mail me **FREE Lesson** with information about big opportunities in **DRAFTING**.

NAME.....AGE.....

ADDRESS.....

CITY.....ZONE.....STATE.....

(Continued from page 6)

able to run checks for two days. One afternoon, we clocked speeds for over an hour on a highway leading from an air force base. With the speed limit at 45 miles per hour, 59 violators were clocked doing from 60 to 75; they were stopped and given warnings. The next day this was repeated over a longer period; necessary warnings dropped to six.

While our radar car covered over 10,500 miles and ran hundreds of checks, a comprehensive study would require months in each state. There are certain observations that can be made:

1. The percent of violations on 25-miles-per-hour streets runs high, from 25 to over 90. In many cases, especially the outskirts of cities, this speed limit may be too low.



2. Speed violations are lower on 30 to 35-miles-per-hour roadways. On the other hand, on superhighways with a 50-miles-per-hour limit, violations run high, considerably higher than on two or three-lane main highways.

3. Motorists tend to drive too fast at night. The hours around midnight are now running second to the sundown period as the most hazardous.

4. Many motorists do not appear to heed important warning signs. It occurred to us that some roads may have too many unimportant signs. It might be worth-while if drivers apprehended for speeding were required to take a series of vision tests to measure acuity, depth perception, glare blindness and other aspects of vision.

5. We cannot put the blame for speeding on drivers of high-powered, modern vehicles, nor any particular age group, for example, younger drivers. Curiously enough, we caught a state highway-department employee and found that he was one of the crew that had recently erected the speed-zone signs!

Anyone who has had the opportunity of working with enforcement officers in the 11 states visited could not fail to recognize the intensive efforts being made to reduce accidents. How much can radar techniques aid in this work? Radar is another scientific

(Continued to page 14)

# INVENTORS

Learn how to protect your invention. The U. S. Patent Laws provide that any new and useful art, machine, article of manufacture, or composition of matter, or any new and useful improvement thereof, may be patented if the act of invention is involved. Therefore, every inventor with a valuable invention should take advantage of the Patent Laws and proceed for patent protection in order to safeguard his rights.

A patent gives the inventor the exclusive right to prevent others from making, using, or selling the invention claimed in the patent for a period of seventeen years.

The Patent Laws were enacted for the benefit of the inventor to give him protection for the features of his invention which are patentable. These features must be properly and concisely set forth and claimed in a formal application for patent, in order to comply with the requirements of the Patent Laws. For that reason, unless the inventor is familiar with patent matters, he should engage a competent registered patent attorney or agent to represent him. We are registered to practice before the U. S. Patent Office and are prepared to serve you in the handling of your patent matters.

A specially prepared booklet entitled "Patent Guide for the Inventor", containing detailed information with respect to patent protection and procedure, together with a "Record of Invention" form will be promptly forwarded to you without obligation upon request.

---

## CLARENCE A. O'BRIEN & HARVEY JACOBSON

*Registered Patent Attorneys*

41-B DISTRICT NATIONAL BUILDING

WASHINGTON 5, D. C.

## Our 40th Year

NRI training is thorough, practical, up-to-date. When you enroll with NRI you benefit from our 40 years of successful experience training men at home.

*J. E. Smith*

President  
National Radio Institute  
Washington, D. C.



# I'll Train You RADIO-

## You Practice Broadcasting with Parts I Send



As part of my Communications Course I send you parts to build low-power Broadcasting Transmitter at left, and other equipment. Use it to get practical experience. You put this station "on the air," perform procedures demanded of station operators. An FCC Commercial Operator's License can be your ticket to a bright future. My Course trains you to get your license. Mail Coupon now!



## Television Is Today's Good Job Maker

Television now reaches from coast-to-coast. More than 25 million Television sets are already in use and require servicing; thousands more sets are being sold every week. About 200 TV stations are now on the air with hundreds more being built. This means new jobs, more jobs, better pay for trained men. The time to act is NOW! Start learning Radio-Television servicing or communications.

## You Practice Servicing with Parts I Send

Nothing takes the place of PRACTICAL EXPERIENCE. NRI training is based on LEARNING BY DOING. You use parts I send to build many circuits common to Radio and TV. You build the modern radio at right. Use Multi-tester you build to make money fixing sets. Many students make \$10, \$15 a week extra fixing neighbors' sets in spare time, starting soon after enrolling. All equipment I send is yours to keep.



## Make Extra Money in Spare Time While Learning

Keep your job while training. Many NRI students make \$10, \$15 and more a week extra fixing neighbors' Radios in spare time. The day you enroll I start sending you special booklets that show you how to service sets. Multi-tester you build helps discover and correct Radio troubles, gives PRACTICAL EXPERIENCE on circuits common to radio and TV. Mail coupon today.



Keep your job while training. Many NRI students make \$10, \$15 and more a week extra fixing neighbors' Radios in spare time. The day you enroll I start sending you special booklets that show you how to service sets. Multi-tester you build helps discover and correct Radio troubles, gives PRACTICAL EXPERIENCE on circuits common to radio and TV. Mail coupon today.

## I Trained these Men at Home



Laborer  
Finds  
Success in  
Radio-TV

"I was a laborer with no future. Now I have a position that pays well. My spare time servicing pays good money, too. Thanks to NRI."—Robert Ford, Johnstown, Pa.



Switched  
to TV  
Servicing

"I recently switched from studio work and am now holding a position as TV service technician. Enjoy my work more and more."—Norman Ward, Ridgely Park, N. J.



Paid for  
Course, Car  
in Spare  
Time

"By the time I graduated I had paid for my course, a car and testing equipment. I can handle any job in Radio-TV."—E. J. Streitberger, New Boston, Ohio



\$10 to \$15  
Week  
Spare Time

"Four months after enrolling, was able to service Radios . . . averaged \$10 to \$15 a week spare time. Now have full time business."—W. Weyde, Brooklyn, N. Y.

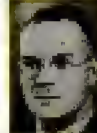

Employed as  
Transmitter  
Operator

"A former employer recommended NRI training to me. Now employed as transmitter operator in Harrisburg."—Albert Herr, New Cumberland, Penna.

# AT HOME for Good Jobs in TELEVISION

There is Success-Good Pay-Security for You in America's Fast Growing Industry



## NRI Training Leads to These Jobs in RADIO-TELEVISION

**BROADCASTING**  
Chief Technician  
Chief Operator  
Power Monitor  
Recording Operator

**SERVICING**  
Home and Auto Radios  
Television Receivers  
P.A. Systems

**MANUFACTURING**  
Design Technician  
Service Manager  
Tester  
Research Assistant

**SHIP AND HARBOR RADIO**  
Chief Operator  
Radiotelephone Operator  
Assistant Operator

**GOVERNMENT RADIO**  
Operator in Army, Navy, Marine Corps  
Airways Operator  
Forestry Dispatcher  
**AVIATION RADIO**  
Transmitter Technician  
Airport Transmitter Operator

**TELEVISION**  
Pick-up Operator  
Technician  
Remote Control Operator  
Service and Maintenance Technician

**POLICE RADIO**  
Transmitter Operator  
Receiver Serviceman

DO YOU want good pay, a job with a bright future, security? Would you like to have a profitable business of your own? If so, find out how you can realize your ambition in the fast-growing RADIO-TELEVISION industry. Even without Television, the industry is bigger than ever before. Just think, over 115 million home and auto Radios, 3000 Radio Broadcasting Stations, plus 25 million Television sets and about 200 Television Broadcasting Stations. Expanding use of Aviation and Police Radio, Micro-wave Relay, Two-way Radio for buses, taxis etc., are making opportunities for Servicing and Communications technicians and FCC Licensed Operators.

### My Training Includes Television

You get practical experience by working on circuits common to both Radio and Television. My graduates are filling jobs, making good money in both Radio and Television. Many NRI trained men start their own Radio and Television servicing business with capital earned in spare time. Let me show you how you can be your own boss; earn \$10 to \$15 a week extra even while still learning. Now is the time to get ready for success in Radio-Television. Coupon below brings you Actual Lesson and 64-page book.

### Find Out What Radio-Television Offers You

What will YOU be doing one year from today? Decide now that you are going to know more and earn more. ACT NOW. Send the coupon below NOW for my FREE DOUBLE OFFER. You get Actual Servicing Lesson. Also my 64-page Book, "How to Be a Success in Radio-Television." Read what my graduates are doing, earning, see equipment you practice with at home. Mail coupon now. Send in envelope or paste on postal. J. E. SMITH, President, Dept. 4BA, National Radio Institute, Washington 9, D. C. Our 40th Year.

### Actual Lesson and 64-page Book

**BOTH FREE**

The ABC's of SERVICING

## MAIL THIS NOW!

MR. J. E. SMITH, President, Dept. 4BA  
National Radio Institute, Washington 9, D. C.

Mail me Sample Lesson and 64-page Book, FREE. (No salesman will call. Please write plainly.)

Name..... Age.....

Address.....

City..... Zone..... State.....

**VETS** write in date of discharge.....



Control Operator, Station WEAN

"Received my License and worked on ships. Now with Station WEAN, NRI Course is no complete as any radio course can be."  
--Raymond E. Arnold, Numford, L. I.

Available to **VETERANS** under G. I. Bills

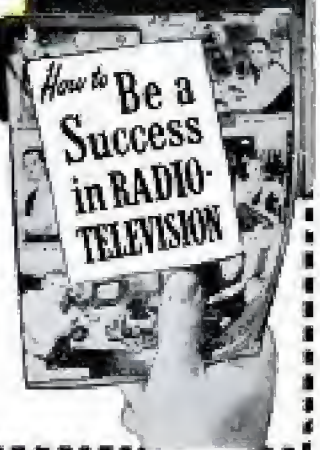

# WHAT ALL AUTO MECHANICS WANT TO KNOW

1664 PAGES



This Big Practical Book gives full information with working diagrams covering the principles, construction, ignition, service and repair of modern cars, trucks and buses.

### Diesel Engines, Hydramatic & Fluid Drives Fully Explained.

A complete Guide of 1664 pages, with over 1500 illustrations showing inside views of working parts, with instructions for service jobs.

### IT PAYS TO KNOW

How to fit pistons—How to locate engine knocks—How to fit connecting rod bearings—How to service main bearings—How to recondition valves—How to time valves—How to adjust fan belts—How to adjust carburetors and chokes, How

to rebuild a clutch—How to service automatic transmissions—How to service brakes—How to adjust steering gear—How to cope with ignition troubles—How to service distributors—How to time ignition—How to "tune up" an engine.



**\$4 COMPLETE - PAY \$1 A MO.**  
TO GET THIS ASSISTANCE FOR YOURSELF SIMPLY FILL IN AND MAIL COUPON TODAY.

Step up your own skill with the facts and figures of your trade. Audel's Mechanics Guides contain Practical Inside Trade Information in a Handy Form, Fully Illustrated and Easy to Understand, Highly Endorsed. Check the book you want for 7 DAYS FREE EXAMINATION, Send No Money, Nothing to pay just now.

## MAIL ORDER



**Check NOW!**

You Can Look Over Any Guide In Your Own Home — Start the Easy Payments If Satisfied

**MAIL THIS TODAY**



AUDEL, Publishers, 49 W. 23 St., NEW YORK 10, N. Y.

Please send me postpaid for FREE EXAMINATION books marked as below. If I decide to keep them I agree to mail \$3 in 7 days on each book or get ordered and further mail \$1 monthly on each book or get until I have paid price, otherwise I will return them.

- AUTOMOBILE MECHANICS GUIDE, \$4
- TRUCK & TRACTOR GUIDE, 1299 Pages . . . 4
- DIESEL ENGINE MANUAL, 575 Pages . . . 2
- MACHINISTS HANDY BOOK, 1650 Pages . . . 4
- WELDERS GUIDE, 400 Pages . . . 1
- BLUE PRINT READING, 416 Pages . . . 2
- MATHEMATICS & CALCULATIONS, 700 Pages . . . 2
- SHEET METAL PATTERN LAYOUTS, 1300 Pages . . . 4
- SHEET METAL WORKERS HANDY BOOK, 398 Pgs. . . 1
- MECHANICAL DRAWING GUIDE, 160 Pages . . . 1
- MECHANICAL DRAWING & DESIGN, 400 Pages . . . 2
- AIRCRAFT WORKER, 240 Pages . . . 1
- TELEVISION SERVICE MANUAL, 384 Pages . . . 2
- RADIIAMANS GUIDE, 914 Pages . . . 4
- ELECTRONIC DEVICES, 216 Pages . . . 2
- ELECTRIC MOTOR GUIDE, 1000 Pages . . . 4
- ELECTRIC WIRING DIAGRAMS, 272 Pages . . . 1
- ELECTRICIANS EXAMINATIONS, 250 Pages . . . 1
- ELECTRIC POWER CALCULATIONS, 425 Pages . . . 2
- HANDY BOOK OF ELECTRICITY, 1440 Pages . . . 4
- ELECTRIC DICTIONARY, 900 Terms . . . 2
- ELECTRIC LIBRARY, 7000 Pages (12 Book Set) 18
- MARINE ENGINEERS HANDY BOOK, 1258 Pgs. . . 4
- SHIPFITTERS HANDY BOOK, 250 Pages . . . 1
- REFRIGERATION & Air Conditioning, 1280 Pgs. . . 4
- MILLWRIGHTS & MECHANICS GUIDE, 1200 Pgs. . . 4
- POWER PLANT ENGINEERS GUIDE, 1500 Pages . . . 4
- ENGINEERS & FIREMANS EXAMS, 525 Pages . . . 1
- PUMPS, Hydraulics & Air Compressors, 1658 Pgs. . . 4
- ENGINEERS LIBRARY (3 Book Set) . . . 9
- MECHANICAL DICTIONARY, 950 Pages . . . 4
- GARDENERS & GROWERS GUIDES (4 Book Set) . . . 6
- CARPENTERS & BUILDERS GUIDES (4 Book Set) . . . 6
- PLUMBERS & Steamfitters Guides (4 Book Set) . . . 6
- MASONS AND BUILDERS GUIDES (4 Book Set) . . . 6
- PAINTERS & DECORATORS MANUAL, 450 Pgs. . . 2
- HOUSE HEATING GUIDE, 1000 Pages . . . 4
- OIL BURNER GUIDE, 384 Pages . . . 1

Name \_\_\_\_\_  
Address \_\_\_\_\_  
Occupation \_\_\_\_\_  
Employed by \_\_\_\_\_

(Continued from page 10)

tool that is now available to local enforcement agencies. It can be used to make speed studies and volume counts. When used with graphic recorders, permanent records can be made for courts and for selective enforcement. But radar is only a tool; it will not eliminate traffic problems. We believe that radar's chief value lies in educating motorists.

Herbert J. Stack, Director,  
Center for Safety Education,  
New York University.  
William J. Toth,  
Staff member of the Center.

### Red Tails in the Sunset

When a French shepherd walked into a bicycle shop in Villebois-Lavalette and requested 130 red reflectors, the proprietor was a bit mystified. What kind of a fleet did he own? The explanation was simple. He



had lost nearly half his flock of sheep to motorists as he herded them along the road after dark. He fastened a red reflector to the tail of each sheep; any motorist discovering 130 sparkling red mirrors on the road in front was likely to slow down, he figured.

### To the Editor:

During recent years, some of our automobiles have been fitted with a half-section horn ring. I happen to have one of them, a 1950 Chevrolet. I was dissatisfied with it the day I bought it and it has been a hazard ever since. I've wondered many times why a necessity on a car should be applied in such an unsafe way, until I read an article in *Popular Mechanics* April 1953 issue by Floyd Clymer, who said that it was too hard to watch the dials with a complete horn ring. (The poor dial watchers.) I've driven automobiles hundreds of thousands of miles during the last thirty years. We all know that all automobiles have blind front corners. It has happened to all of us, including myself, that while turning a corner a human being suddenly pops into view from around that blind corner. It's a funny feeling. The steering wheel being turned,

(Continued to page 304)





# Are you too old to learn?

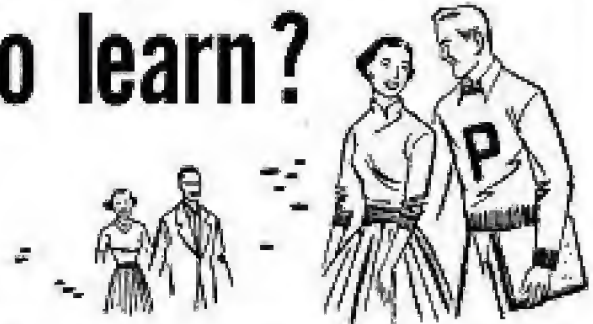

not at all, new tests show!

## EXPERT SAYS YOU CAN LEARN NEW TRICKS!

New tests, cited by an expert in news stories, show that: your ability to think increases with age; your powers of deduction are greater; your judgment is better.

**I. C. S. KNEW IT ALL THE TIME!** In the I. C. S. files are thousands of case histories of men and women of every age. Their successes, their promotions, their raises prove that men and women past school age can learn! Listen to A.L.G.\* "Up until I took the course, I did what I was told. But now . . . I tell others what to do."

**I. C. S. GIVES YOU EXPERT GUIDANCE FREE!** Do you have the feeling you're "stuck" in your job?

Your trained I. C. S. counselor will appraise your abilities, help you plan for the future. Listen to D.F.K.\* "Before enrolling, I was a foundry laborer. Today I am a draftsman, enjoying a 1/2 increase in salary."

**IT'S NEVER TOO LATE TO GET STARTED!** You study with I. C. S. at home, in your spare time. There's no interference with business or social activity. Famous I. C. S. texts make learning easy. And whatever your age, you're more capable now than you've ever been. But don't delay! Pick your field from the coupon below. Mail the coupon today! We'll send free "success" book, survey of opportunities in your field! *Mail now for 2 free books.*

\*Names on request

I. C. S., Scranton 9, Penna.

## INTERNATIONAL CORRESPONDENCE SCHOOLS

ICS

BOX 5612-L, SCRANTON 9, PENNA.

Without cost or obligation, send me "HOW TO SUCCEED" and the booklet about the course BEFORE which I have marked X:

- |   |   |  |   |   |
|---|---|--|---|---|
| <p><b>ART</b></p> <ul style="list-style-type: none"> <li><input type="checkbox"/> Commercial Art</li> <li><input type="checkbox"/> Magazine Illustrating</li> <li><input type="checkbox"/> Fashion Illustrating</li> <li><input type="checkbox"/> Cartooning</li> <li><input type="checkbox"/> Sketching and Painting</li> <li><input type="checkbox"/> Show Card and Sign Lettering</li> </ul> <p><b>AUTOMOTIVE</b></p> <ul style="list-style-type: none"> <li><input type="checkbox"/> Automobile Mechanic</li> <li><input type="checkbox"/> Auto Elec. Technician</li> <li><input type="checkbox"/> Auto Body Rebuilding and Refinishing</li> <li><input type="checkbox"/> Diesel—Gas Engines</li> </ul> <p><b>AVIATION</b></p> <ul style="list-style-type: none"> <li><input type="checkbox"/> Aeronautical Engineering Jr.</li> <li><input type="checkbox"/> Aircraft Engine Mechanic</li> <li><input type="checkbox"/> Airplane Drafting</li> </ul> <p><b>BUILDING</b></p> <ul style="list-style-type: none"> <li><input type="checkbox"/> Architecture</li> <li><input type="checkbox"/> Arch. Drafting</li> <li><input type="checkbox"/> Building Contractor</li> <li><input type="checkbox"/> Estimating</li> <li><input type="checkbox"/> Carpenter and Mill Work</li> <li><input type="checkbox"/> Carpenter Foreman</li> <li><input type="checkbox"/> Reading Blueprints</li> <li><input type="checkbox"/> House Planning</li> <li><input type="checkbox"/> Plumbing</li> </ul> | <ul style="list-style-type: none"> <li><input type="checkbox"/> Heating</li> <li><input type="checkbox"/> Painting Contractor</li> <li><input type="checkbox"/> Air Conditioning</li> <li><input type="checkbox"/> Electrician</li> </ul> <p><b>BUSINESS</b></p> <ul style="list-style-type: none"> <li><input type="checkbox"/> Business Administration</li> <li><input type="checkbox"/> Certified Public Accountant</li> <li><input type="checkbox"/> Bookkeeping and Accounting</li> <li><input type="checkbox"/> Office Management</li> <li><input type="checkbox"/> Stenography and Typing</li> <li><input type="checkbox"/> Secretarial</li> <li><input type="checkbox"/> Federal Tax</li> <li><input type="checkbox"/> Business Correspondence</li> <li><input type="checkbox"/> Letter-writing Improvement</li> <li><input type="checkbox"/> Personnel and Labor Relations</li> <li><input type="checkbox"/> Advertising</li> <li><input type="checkbox"/> Retail Business Management</li> <li><input type="checkbox"/> Managing Small Business</li> <li><input type="checkbox"/> Ocean Navigation</li> <li><input type="checkbox"/> Sales Management</li> <li><input type="checkbox"/> Short Story Writing</li> <li><input type="checkbox"/> Creative Salesmanship</li> <li><input type="checkbox"/> Traffic Management</li> </ul> <p><b>CHEMISTRY</b></p> <ul style="list-style-type: none"> <li><input type="checkbox"/> Chemical Engineering</li> <li><input type="checkbox"/> Chemistry</li> <li><input type="checkbox"/> Analytical Chemistry</li> </ul> | <ul style="list-style-type: none"> <li><input type="checkbox"/> Petroleum—Nat'l Gas</li> <li><input type="checkbox"/> Pulp and Paper Making</li> <li><input type="checkbox"/> Plastics</li> </ul> <p><b>CIVIL, STRUCTURAL ENGINEERING</b></p> <ul style="list-style-type: none"> <li><input type="checkbox"/> Civil Engineering</li> <li><input type="checkbox"/> Structural Engineering</li> <li><input type="checkbox"/> Surveying and Mapping</li> <li><input type="checkbox"/> Structural Drafting</li> <li><input type="checkbox"/> Highway Engineering</li> <li><input type="checkbox"/> Reading Blueprints</li> <li><input type="checkbox"/> Construction Engineering</li> <li><input type="checkbox"/> Sanitary Engineering</li> </ul> <p><b>DRAFTING</b></p> <ul style="list-style-type: none"> <li><input type="checkbox"/> Aircraft Drafting</li> <li><input type="checkbox"/> Architectural Drafting</li> <li><input type="checkbox"/> Electrical Drafting</li> <li><input type="checkbox"/> Mechanical Drafting</li> <li><input type="checkbox"/> Structural Drafting</li> <li><input type="checkbox"/> Sheet Metal Drafting</li> <li><input type="checkbox"/> Ship Drafting</li> <li><input type="checkbox"/> Mine Surveying and Drafting</li> </ul> <p><b>ELECTRICAL</b></p> <ul style="list-style-type: none"> <li><input type="checkbox"/> Electrical Engineering</li> <li><input type="checkbox"/> Electrician</li> <li><input type="checkbox"/> Electrical Maintenance</li> </ul> | <ul style="list-style-type: none"> <li><input type="checkbox"/> Electrical Drafting</li> <li><input type="checkbox"/> Electric Power and Light</li> <li><input type="checkbox"/> Lineman</li> </ul> <p><b>HIGH SCHOOL</b></p> <ul style="list-style-type: none"> <li><input type="checkbox"/> High School Subjects</li> <li><input type="checkbox"/> Mathematics</li> <li><input type="checkbox"/> Commercial</li> <li><input type="checkbox"/> Good English</li> </ul> <p><b>MECHANICAL AND SHOP</b></p> <ul style="list-style-type: none"> <li><input type="checkbox"/> Mechanical Engineering</li> <li><input type="checkbox"/> Industrial Engineering</li> <li><input type="checkbox"/> Industrial Supervision</li> <li><input type="checkbox"/> Foremanship</li> <li><input type="checkbox"/> Mechanical Drafting</li> <li><input type="checkbox"/> Machine Design-Drafting</li> <li><input type="checkbox"/> Machine Shop Practice</li> <li><input type="checkbox"/> Tool Design</li> <li><input type="checkbox"/> Industrial Instrumentation</li> <li><input type="checkbox"/> Machine Shop Inspection</li> <li><input type="checkbox"/> Reading Blueprints</li> <li><input type="checkbox"/> Toolmaking</li> <li><input type="checkbox"/> Gas—Electric Welding</li> <li><input type="checkbox"/> Heat Treatment—Metallurgy</li> <li><input type="checkbox"/> Sheet Metal Work</li> <li><input type="checkbox"/> Sheet Metal Pattern Drafting</li> <li><input type="checkbox"/> Refrigeration</li> </ul> | <p><b>POWER</b></p> <ul style="list-style-type: none"> <li><input type="checkbox"/> Combustion Engineering</li> <li><input type="checkbox"/> Diesel—Electric</li> <li><input type="checkbox"/> Electric Light and Power</li> <li><input type="checkbox"/> Stationary Steam Engineering</li> <li><input type="checkbox"/> Stationary Fireman</li> </ul> <p><b>RADIO, TELEVISION COMMUNICATIONS</b></p> <ul style="list-style-type: none"> <li><input type="checkbox"/> Practical Radio—TV Engineering</li> <li><input type="checkbox"/> Radio Operating</li> <li><input type="checkbox"/> Radio and TV Servicing</li> <li><input type="checkbox"/> Television—Technician</li> <li><input type="checkbox"/> Electronics</li> <li><input type="checkbox"/> Telephone Work</li> </ul> <p><b>RAILROAD</b></p> <ul style="list-style-type: none"> <li><input type="checkbox"/> Locomotive Engineer</li> <li><input type="checkbox"/> Diesel Locomotive</li> <li><input type="checkbox"/> Air Brakes <input type="checkbox"/> Car Inspector</li> <li><input type="checkbox"/> Railroad Administration</li> </ul> <p><b>TEXTILE</b></p> <ul style="list-style-type: none"> <li><input type="checkbox"/> Textile Engineering</li> <li><input type="checkbox"/> Cotton, Rayon, Woolen Mfg.</li> <li><input type="checkbox"/> Carding and Spinning</li> <li><input type="checkbox"/> Weaving and Finishing</li> <li><input type="checkbox"/> Loom Fixing <input type="checkbox"/> Throwing</li> <li><input type="checkbox"/> Finishing and Dyeing</li> <li><input type="checkbox"/> Textile Designing</li> </ul> |
|---|---|--|---|---|

Name \_\_\_\_\_ Age \_\_\_\_\_ Home Address \_\_\_\_\_

City \_\_\_\_\_ Zone \_\_\_\_\_ State \_\_\_\_\_ Working Hours \_\_\_\_\_ A.M. to P.M. \_\_\_\_\_

Occupation \_\_\_\_\_

Canadian residents send coupon to International Correspondence Schools Canadian, Ltd., Montreal, Canada. . . . Special tuition rates to members of the U. S. Armed Forces.



with **SUPERSHOP**

**5 BIG POWER TOOLS IN 1**

- 8" TILTING TABLE SAW
- 1/2" DRILL PRESS
- 8" SANDER
- 30" LATHE
- 5" GRINDER

When you **DO-IT-YOUR-SELF** with **SUPERSHOP** you save money and you have fun. You can build a house or a garage — handle **BIG** jobs. The 8 inch saw cuts 2 1/2 inches deep. Heavy tubular steel frame. 100% Ball Bearing. Lifetime accuracy. Save \$65.05—buy direct from factory. Take advantage of our **FREE** trial plan. You can buy on **EASY TERMS**. Write for **FREE How-To-Do-It Catalog**.



**DRILL PRESS**



**SANDER**



**LATHE**



**GRINDER**

Write for **FREE How-To-Do-It Catalog**.

WRITE FOR YOUR COPY SEND POSTCARD	FACTORY TO YOU <b>\$79<sup>95</sup></b> EASY PAY PLAN
--------------------------------------	---

**POWER TOOLS INC.** 156A Yates Ave. Beloit, Wis.

**WHERE-TO-BUY-IT INDEX**

Source of supply appears after items commercially available

**AUTOMOTIVE**

Radio automatically times cars at Indianapolis speedway (Albert W. Bloemker, Indianapolis Motor Spdwy. Corp., Indianapolis 4, Ind.).....131  
 Tag-along trailer supports rear end of 88-foot load.....132  
 Ford gets an all new V8—and Mercury does too.....161  
 A trans-Atlantic view of Europe's 1954 models.....172  
 Hand-built car.....258

**AUTOMOTIVE ACCESSORIES**

Brake-fluid indicator (Formost Auto Specialty, 3559 S. Chicago Ave., Chicago 19, Ill.).....127  
 Light monitor warns driver (E. Edelmann & Co., 2332 W. Logan Blvd., Chicago 47, Ill.).....127  
 "Stop Space" speedometer shows minimum distance.....127  
 Variable-speed supercharger for stock cars boosts power (McCulloch Motors Corp., 8101 W. Century Blvd., Los Angeles).....138  
 Hydraulic four-wheel drive operates German bus.....133

**AVIATION**

Guided missiles on leash.....97  
 Icebreaker carries helicopter for survey and rescue work.....104  
 Midget gas turbine helps run world's largest cargo airplane (Solar Aircraft Co., 2200 Pacific Highway, San Diego 12, Calif.).....133  
 Television joins the air force.....134  
 Two-foot-wide propeller blades to be turned by 3500 horsepower engine.....143  
 High living for mechanics.....302

**CONSTRUCTION**

Toy blocks teach farm construction.....109  
 Lightweight scaffolding goes together without nuts or bolts...103  
 Fireproof roofing of wood fibers also provides insulation.....109  
 College students build rig and drill well without expecting gusher.....132  
 Prestressed concrete girders cut building costs.....202

**FARM**

"Field hands" with wings keep cotton field clean.....105  
 Posthole digger makes square cut.....125  
 Snails enrich feed.....139

**HOUSE AND HOME**

Japanese telephone cord reel prevents line from snarling....105  
 Self feeding bird trough holds five day supply (Pioneer Pet Supply, 107 N. Cuyler, Oak Park, Ill.).....104  
 Musical slide rule aids composition and transcription (Prof. L. E. Woodman, Missouri School of Mines, Rolla, Mo.).....109  
 Cherry pitter.....116  
 Fat filler (Tricolator Co., Inc., 321 Jelliff Ave., Newark 8, N. J.).....116  
 Gem setter (Gem-Craft, 1813 East 13th St., Cleveland 14, Ohio).....116  
 Potato peeler (Hoffritz for Cutlery, 551 Fifth Ave., New York, N. Y.).....117  
 Round thermostat (Minneapolis-Honeywell Regulator Co., 2954 4th Ave. S., Minneapolis 8, Minn.).....117  
 Sprayer (Garden Hose Spray Co., Inc., 7 Upland Road, Cambridge 40, Mass.).....117  
 Vapor strip (L. S. Root Laboratories, Inc., 1049 48th Road, Long Island 1, N. Y.).....117  
 Quickly donned plastic coveralls protect clothes from grease (Car-Blair, Ltd., 43 W. 57th St., New York 19, N. Y.).....125  
 Race-car decals (Falm Bros. Decalcomania Co., Box 20, Cincinnati 7, Ohio).....127  
 Do it with staples (Bostitch Co., Westerly, Rhode Island; Heller Co., 2135 Superior Ave., Cleveland 14, Ohio).....128  
 Automatic "sniffer" detects leaking gas.....128  
 Radiant-glass heating panels.....253  
 Interceptor waste trap (Mr. C&H Plumbing Specialties, 3148 Bruckner Blvd., New York 61, N. Y.).....309

(Continued to page 26)

# INVENTORS

If you believe that you have an invention, you should find out how to protect it. The first step is to have a search made of the prior pertinent U. S. patents. If a report on this search indicates that the invention appears patentable you can apply for a patent, and the specifications and claims should be prepared.

The firm of McMorrow, Berman & Davidson, with offices in Washington, D. C., is qualified to take the necessary steps for you. We can make a preliminary search on your invention, advise you whether we think it can be patented, and prepare your application for patent.

Unless you are fully familiar with the U. S. Patent Laws, we recommend that you engage the services of a Registered Patent Attorney to protect your interests. The patent laws are *your* laws. A patent gives you the right to prevent others from making, using or selling the invention claimed in your patent for a period of 17 years.

Use these patent laws for your protection. Investigate whether your invention can be patented. If you have what you believe to be an invention, we suggest that you have this firm make a search for you.

*Send for a copy of our Patent Booklet entitled "How To Protect Your Invention," containing information about patent protection and patent procedure. Along with this we will also send you an "Invention Record" form, for your use in writing down and sketching details of your invention. We will mail them promptly. No obligation. They are yours for the asking.*

## McMORROW, BERMAN & DAVIDSON

*Registered Patent Attorneys*

PATENTS • COPYRIGHTS • PATENTS

135-Y VICTOR BUILDING, WASHINGTON 1, D. C.

## "OWN a Business" Coupon

**DURACLEAN CO., 4-162 Duraclean Bldg., Deerfield, Ill., U.S.A.**

Without obligation to me, send booklet and letter giving full details. Tell me how I may OWN a growing business of my own built upon satisfied customers.

Name \_\_\_\_\_

Address \_\_\_\_\_

City \_\_\_\_\_ State \_\_\_\_\_

Start Now . . .  
while employed



# Are You The Man?

If you have longed for the prestige and financial independence of YOUR OWN business, you can now realize this desire . . . if you can qualify for a Duraclean dealership. We are now enlarging this 24-year-old chain of independently-owned service dealerships which has rapidly grown to a world-wide service.

You must however be reliable, honest, diligent, and able to make a small investment in a business of your own . . . a profession for which we will personally and quickly train you. If needed, we will help finance you.

We want to assure your success. A Duraclean dealer will train and assist you. He'll reveal his successful plan of building customers. He will work with you. This business is easy to learn . . . quickly established.

This is a sound, lifetime business that grows from REPEAT ORDERS and customer RECOMMENDATIONS. Alert dealers can gross an hourly profit of \$5.00 on own service plus \$3.00 on EACH service-man at National Price Guide charges.

**You are Trained in a New Profession . . . to Revive, Clean, Protect Home Furnishings**  
**You have a World-wide, High-profit Service . . . rendered IN homes, offices, institutions**

You have the prestige, independence and financial security of YOUR OWN business. You have the opportunity to steadily increase the income for your family month after month and year after year without waiting for a raise.

Duraclean dealers enjoy unusual profit on both materials and labor . . . after paying servicemen or salesmen. Service is rendered IN the home. Some have shops or offices . . . others operate from their home with no overhead expense. No experience is needed. We show you 27 ways to bring customers to you. YOUR service is Nationally Advertised in magazines like Better Homes & Gardens, McCall's, House & Garden, Life, Maclean's (Canada's leading magazine), House Beautiful, etc.

Almost every building houses a customer needing one or both services. Furniture stores, department stores, interior decorators, upholsterers and carpet stores develop Duracleaning and Duraproofing jobs from their customers. Auto dealers take orders and have used cars Duracleaned.

You have cooperation of a 24 year old WORLD-WIDE organization interested in YOUR personal success. You have a profit margin permitting a high hourly income from the day you start . . . even while still employed.

### Duraclean Revolutionizes Old Methods

Duraclean's growth to a world-wide service resulted from customer convenience plus its many superiorities over ordinary cleaning. Housewives, clubs, hotels, offices and institutions deeply appreciate not having furnishings out of use for days and weeks.

They are thrilled to see their upholstery and floor coverings cleaned and revived with a new consideration for its life and beauty. DURACLEAN doesn't merely clean . . . it restores natural lubrication to wool and other fibers. Colors revive. The re-enlivened rug and carpet pile unmat and frays.

Aerated foam created by the electric Foamovator banishes dirt, grease and many unsightly spots . . . without scrubbing. Customers tell friends how Duraclean has eliminated customary soaking, shrinking and breaking of fibers from scrubbing . . . how the mild aulek action foam, lightly applied, provides safety from color runs and roughened fabric they have previously experienced . . . how fabrics look fresher, brighter, cleaner . . . how convenient it is not to have furnishings gone.

They appreciate the courteous, personalized service of Duraclean craftsmen. Such service is NEWS . . . it spreads to friends and neighbors. Customers become your best salesmen.

### Duraproof Stops Moth & Beetle Damage

Duraproof Service not only kills moths and carpet-beetles . . . It is WARRANTED to make fabrics repellent to both. The U. S. Government says, "Moths are present in practically every household . . . no section of the country seems free from such infestations." Damage to household goods and wearing apparel is greater from moths than fire. This modern treatment PROTECTS rugs, carpets, upholstery, furs, clothing, blankets, piano-felts, auto interiors, etc.

**EASY TERMS:** First payment establishes your business . . . pay balance from sales. We furnish electric machines, folders, store-cards, introduction slips, sales book, demonstrators and enough materials to return TOTAL investment.

### FREE Booklet . . . Send for it NOW

Our first letter and illustrated booklet will explain everything . . . modern services, waiting market, how business grows, your large profit and PROTECTED territory. You can have your business operating in a very few days. Mail coupon today while you can still get a dealership in YOUR location.

**DURACLEAN CO., 4-162 Duraclean Bldg., Deerfield, Illinois**

### What Dealers Say

Fuller Monroe: "I give full time to estimating and supervising. We average 20 hourly income per service man but our man today produced \$118.00."

T. Komart (Japan): "Have 1,000,000 yen contract Duracleaning for U.S. Army."

W. Lookishill: "We've had 20 years of pleasant dealings. I'm 65 but am setting my sights for 20 more years."

P. Freidinger: "Had a big moth-proof business last year; one job was \$322.25."

R. Kinsburgh: "Finished First White House of Confederacy and am to Duraclean the Governor's Mansion."

H. Satterfield: "Duracleaned chair for largest department store and got order for 60 to 75 chairs, couches and daybeds."

M. Szwed: "The customers I had in House and Garden ads were very pleased. Their furnishings came out beautiful."

A. Ullman: "It is very encouraging that every demonstration has been a sale."

L. Johnson: "Each customer leads to 3 or 4 more. One job two of us cleaned \$125 worth in 3 hours."

**OWN  
a Growing  
BUSINESS**

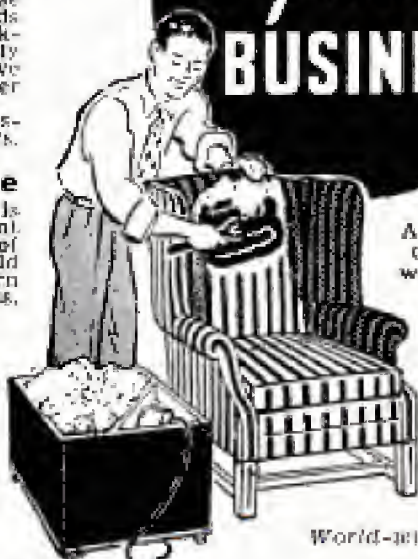

A Duraclean dealer will work with you

World-wide Services

**Train QUICK  
in Big Coyne  
Shops**

# GREAT OPPORTUNITY FIELDS!



*Instructor helping students check the wiring and trace the circuits of television receivers.*

*Instructor explaining operation and testing of a large Motor Generator.*

*This big fire-proof building is occupied entirely by Coyne.*

## TRAINED YOUNG AND OLDER MEN— URGENTLY NEEDED IN VITAL FIELDS!

**ELECTRICITY—RADIO—TELEVISION—ELECTRONICS—VITAL** in defense program. Trained men whether 16 or up to 50 needed. **TRAIN QUICKLY** for better rating if drafted—Vital job in industry if not.

## LARGEST, OLDEST, BEST EQUIPPED SCHOOL OF ITS KIND IN THE U.S.

### TELEVISION-RADIO      ELECTRICITY

Here at COYNE you're retrained for Television, Testing, Trouble-Shooting on Radio, Public Address, F. M. Sound Units, etc. Many Coyne trained men in good jobs or own well paying Television-Radio businesses of their own.

Big future in Power Plant Work, Motors, Industrial Electronics, Armature Winding, Home and Factory Wiring, Appliances, Refrigeration, Maintenance, Illumination, etc. Lifetime job service to Coyne graduates.

### WE TRAIN YOU IN CHICAGO

Our famous Practical-Technical method gives you practical experience on a massive outlay of equipment. Actual shop work plus necessary technical training. You are trained right here in the great Coyne shops. Send for BIG FREE BOOK.



### Mail Coupon for Big FREE Book!

Whether you prefer Television-Radio or Electricity, train on actual equipment at Coyne. We will send you a Big, fully illustrated Book. Indicate below which course interests you most. No salesman will call. Mail coupon TODAY.

**APPROVED  
FOR  
VETERANS**

### START NOW—PAY LATER

Enroll now, pay most of tuition after graduation. Special plan for men of draft age. We'll help you get part-time work, if you need it to help pay living costs while at Coyne.

B. W. COOKE, President

**COYNE**  
SCHOOL

**A TECHNICAL TRADE INSTITUTE  
CHARTERED NOT FOR PROFIT**  
Established 1899  
500 S. Paulina Dept. 24-72H  
Chicago 12, Illinois

**ELECTRICITY ★ TELEVISION ★ RADIO ★ REFRIGERATION ★ ELECTRONICS**

B. W. Cooke, President  
COYNE SCHOOL, 500 S. Paulina St.  
Dept. 24-72H, Chicago 12, Ill.

Send me your Big Free book. I am interested in field checked below. This does not obligate me.

TELEVISION-RADIO       ELECTRICITY

NAME.....

ADDRESS.....

CITY.....STATE.....

# WHAT SECRET POWER DID THIS MAN POSSESS?



**BENJAMIN FRANKLIN**  
(A Rosicrucian)

**WHY** was this man great? How does anyone—man or woman—achieve greatness? Is it not by mastery of the powers within ourselves? Know the mysterious world within you! Attune yourself to the wisdom of the ages! Grasp the inner power of your mind! Learn the secrets of a full and peaceful life!

Benjamin Franklin—like many other learned and great men and women—was a Rosicrucian. The Rosicrucians (NOT a religious organization) first came to America in 1694. Today, headquarters of the Rosicrucians send over seven million pieces of mail annually to all parts of the world. Write for YOUR FREE COPY of "The Mastery of Life"—TODAY. No obligation. No salesmen. A non-profit organization. Address: Scribe C.T.F.

**THIS BOOK FREE!**

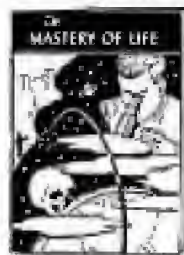

## The ROSICRUCIANS

SAN JOSE • (AMORC) • CALIFORNIA

SEND THIS COUPON

Scribe C.T.F.  
The ROSICRUCIANS (AMORC)  
San Jose, California  
Please send me the free book, *The Mastery of Life*, which explains how I may learn to use my faculties and powers of mind.

Name \_\_\_\_\_

Address \_\_\_\_\_

City \_\_\_\_\_

(Continued from page 10)  
**INDUSTRIAL**

Fire recovers oil.....	103
Cartridge prevents rust in fuel oil tanks (Sudbury Laboratory, South Sudbury, Mass.).....	125
Expansion plug seals end of open tube (Imperial Brass Mfg. Co., 1200 W. Harrison St., Chicago 7, Ill.).....	278
Plastic tool pulls fuses (Star Fuse Co., 235 Canal St., New York, N. Y.).....	285
Chemical rust-cutter (James H. Kearney Corp., 4230 Clayton Ave., St. Louis 10, Mo.).....	303

**SCIENCE**

Massive iron ball at center of earth.....	104
"Scanner" finds submerged objects with bouncing beam of sound (Minneapolis-Honeywell Regulator Co., 2954 4th Ave. S., Minneapolis 8, Minn.).....	115
Daped and frozen fish withstand transfer to new house.....	131
Electronic "nose".....	131
Engineer is safe in steel wire cage charged with 300,000 volts.....	131
X Ray pictures in color.....	143
Eye-movement glasses (Audio-Visual Research, 531 S. Plymouth Court, Chicago 5, Ill.).....	274
Light-powered clock.....	300

**MISCELLANEOUS**

Armor for hunters.....	22
Paint-saving chemical (Mazmac Co., 79 W. Grand St., Mt. Vernon, N. Y.).....	103
Stilt-legged cyclist draws attention of Berliners to circus.....	104
Fly your boat to the fishing hole.....	106
Mobile traffic signal is powered by battery.....	108
Suspension camera nearly 10 yards long is operating in Tokyo.....	108
Vacuum-canned milk retains fresh taste.....	125
Mold-making machine cuts costs 30 percent.....	138
Elaborate mechanism works and works to do nothing well.....	139
Ivan, the retrospective inventor.....	140
Pump moves water in ship from side to side to minimize roll.....	143
Oklahoma drive-in library features curbside service.....	256
Bidding wheel.....	256

### Craftsman and Shop Notes Index

**FARM**

Self feeder gives shelter and storage space.....	220
Double field gates used on farm accommodate machinery.....	221
Planks check light tractor for belt work.....	221
Gate speeds up stock handling.....	241
Heavy iron floor stand steadies farm grinder.....	244

**HOUSE AND HOME**

Three sewing cabinets from single design.....	185
Dog bed provided by old tire.....	190
Auto trunk brackets used as folding table braces.....	194
Nails to hang pictures on wall driven with hand drill.....	194
Rubber hose over pliers handle prevents hand chafing.....	194
Night flying insects controlled by use of proper lighting.....	195
Shellac preserves ball bat.....	195
Solving Home Problems.....	196
Glasses stuck together.....	198
Removing wax from wallpaper.....	198
Modern table lamps.....	199
Clothespin used to retrieve articles.....	203
Converting vase into lamp base without drilling for pipe or wire.....	202
Stove mats protect walls and furniture tops.....	204
Baby's dressing table and chest made from second hand desk.....	204
Cotton packing in bottles removed by wood screw.....	204
Screening frayed at edges nailed to new support.....	204
Baseboard light in closet aids selection of clothes.....	210
Cupboard latch improvised from spring clothespin.....	210
Photograph needle protected by cellulose sponge on arm.....	210

(Continued to page 22)

**IMPORTANT NOTICE**—It is the intention of this magazine to provide its readers with information regarding the latest developments in the mechanical arts. We take no responsibility as to whether the disclosures contained in our articles are covered by patents and advise readers to investigate this subject before making, using, or selling any of the products, machines, or processes described in order to avoid possible liability for patent infringements.

# START YOUR FUTURE TODAY!

Get the facts on NATIONAL SCHOOLS' famous Shop-Method Home Training!

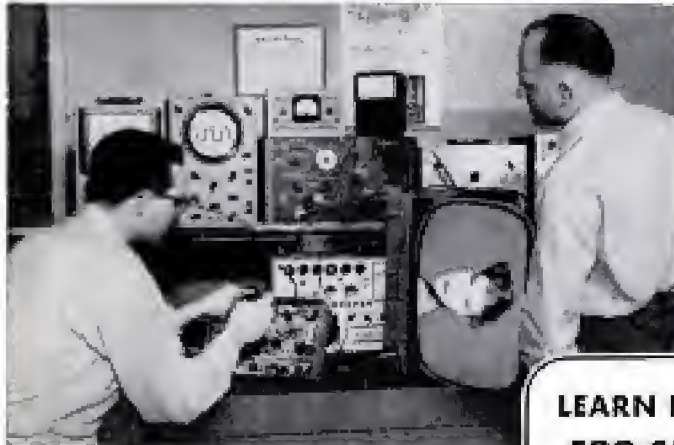

## RADIO-TELEVISION & ELECTRONICS

A BRIGHT FUTURE awaits you in booming Radio-TV industry. More than 100 million radio sets, 20 million TV sets, now in use! Backed by National Schools' famous Shop-Method Training from America's Radio-TV Capital you can command good wages in the opportunity-career of your choice — engineer, service-repair, inspector, designer — in radar, electronics — or your own profitable business! Make that bright future come true... start now!

**WE GIVE YOU COMPLETE PARTS, INCLUDING HIGH-MU TUBES!**

Yours to keep. You learn by doing, actually build

generators, R-F oscillators, and this big Super-Het receiver!

**WE GIVE YOU THIS STANDARD PROFESSIONAL MULTITESTER!**

Locates trouble, adjusts delicate circuits—a valuable profit-earner

for you when you become a qualified Radio-TV technician!



**FREE! RADIO-TV BOOK & LESSON!**



**FREE! AUTO-DIESEL BOOK & LESSON!**

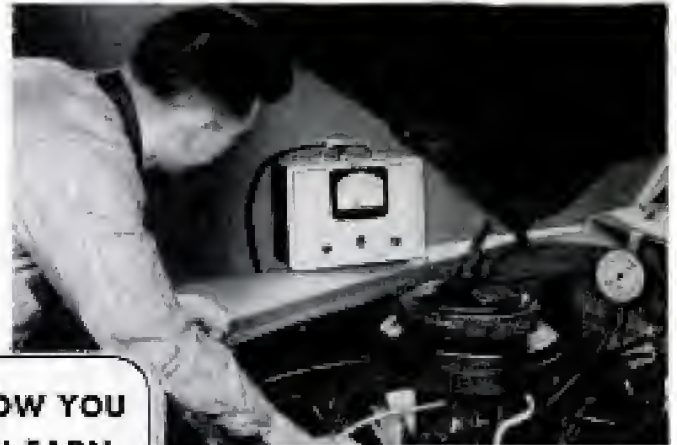

## AUTOMOTIVE-DIESEL & ALLIED MECHANICS

EXPANDING AUTO-DIESEL INDUSTRY needs more and more trained men! 55 million vehicles now operating, 8 million more this year—plus 150,000 new Diesel units! Garages, car dealers, transit lines, defense plants, manufacturers, are desperate for

the kind of trained specialists produced by National Schools' "Shop-Method Home Training." Start now on the road to lifetime security. Mail the coupon today!

**WE GIVE YOU THE TOOLS OF YOUR TRADE!** This fully-equipped, all-metal Tool Kit is yours

to keep. We also give you a complete set of precision drawing instruments, and Slide Rule. These professional tools help you learn, then earn!



## NATIONAL SCHOOLS

Technical Trade Training Since 1905

LOS ANGELES 37, CALIFORNIA

In Canada: 811 West Hastings Street

Vancouver, B.C.

Both Home Study and Resident Courses Offered

**LEARN HOW YOU TOO CAN EARN TOP MONEY IN THESE BOOMING INDUSTRIES!**



LET NATIONAL SCHOOLS of Los Angeles, California, a Resident Technical Trade School for nearly half a century, train you at home for a high-paying future in these big-future industries.

### Earn While You Learn!

Make extra money repairing friends' and neighbors' cars, trucks, radios, TV sets, appliances. Every step fully explained and illustrated in National Schools' famous "Shop-Tested" lessons. Latest equipment and techniques covered. You master all phases—start part-time earnings after a few weeks!

**YOU RECEIVE FRIENDLY GUIDANCE**, both as a student and graduate. Our special Welfare Department is always at your service, to help you with technical and personal problems. You receive full benefit of our wide industry contacts and experience.

**DRAFT AGE?** National Schools training helps you get the service branch, and higher pay grade you want.



**APPROVED FOR G. I. TRAINING**

These courses also offered in Spanish and Portuguese

**MAIL COUPON NOW START YOUR HIGH-PAYING FUTURE TODAY!**

**GET FACTS FASTEST! MAIL TO OFFICE NEAREST YOU!**

(Mail in envelope or paste on postal card)

**NATIONAL SCHOOLS, Dept. B-24**

4000 S. Figueroa Street Los Angeles 37, Calif. or 323 West Park Street Chicago 7, Ill.

Please rush Free Book & Sample Lesson checked below. No obligation, no salesman will call.

"My Future is Radio-Television & Electronics"  
 "My Future is Automotive-Diesel & Allied Mechanics"

NAME \_\_\_\_\_ BIRTHDAY \_\_\_\_\_ 19\_\_\_\_

ADDRESS \_\_\_\_\_

CITY \_\_\_\_\_ ZONE \_\_\_\_\_ STATE \_\_\_\_\_

Check here if interested in Resident School Training at Los Angeles. **VETERANS:** Give Date of Discharge \_\_\_\_\_

## TRY CORTINA'S SHORT-CUT TO



MORE MONEY NEW CAREER CULTURAL ENJOYMENT TRAVEL FUN

MAIL COUPON FOR

# FREE RECORD

START SPEAKING

# SPANISH or FRENCH



**ALMOST OVERNIGHT!**

MAIL coupon for double-sided, non-breakable record and sample lesson. BOTH FREE! Listen as native instructor speaks to you on record. Let your eyes follow words in sample lesson at same time. Before you realize it, you'll be "chatting" easily in your new language—with a perfect accent!

Now's the time to learn a new language. It gives you such an advantage in business, social life. And here's the easiest way to learn—by listening! You gain a perfect accent (that's all you hear!) You don't learn grammar the "hard way"; you pick it up in CONVERSATION.

### MAIL COUPON NOW

There are no "strings" to this offer. But it may end soon. Hurry! Rush coupon with 25c to help cover cost of special packing, shipping. We'll also send FREE book describing full Cortina course. No obligation.

Also:

GERMAN  
ITALIAN  
RUSSIAN  
JAPANESE  
BRAZILIAN

## CORTINA ACADEMY

(Originators of Phonograph Method)

Dept. 642, 136 W. 52nd Street, New York 19, N. Y.

MAIL AT ONCE FOR *Free* RECORD

CORTINA ACADEMY, Dept. 642, (Est. 1882)  
136 W. 52nd Street, New York 19, N. Y.

Please send me a FREE sample lesson in (check one)

SPANISH  FRENCH  RUSSIAN  GERMAN  
 ITALIAN  JAPANESE  BRAZILIAN

and information about full Cortina course. Enclosed in 25c (stamp or coin) to help cover the cost of special packaging, shipping.

Name \_\_\_\_\_

Address \_\_\_\_\_

City \_\_\_\_\_ Zone \_\_\_\_\_ State \_\_\_\_\_

(Continued from page 20)

Lightning bug night light.....	211
Inexpensive way to coat nails for use on special jobs.....	233
Novel blueprint lamp shade for den or workshop.....	240
Clink for Homemakers.....	252

### PHOTOGRAPHY

Don't let dusty holders spoil your negatives.....	195
Full-color image projector made in a few minutes.....	198
Air condition your darkroom.....	203

### TOOLS

Adjustable drafting curve from hacksaw blade.....	194
Kinks in copper tubing removed with aid of wooden paddle.....	198
Grinding lathe bits of shaper.....	226
Internally threaded sleeves knurled on special mandrel.....	228
Modified portable hand router cuts accurate circles.....	233
Work mounted on steel balls prevents wear of centers.....	241
Shopping for Tools.....	242
New life for socket wrenches.....	244
Padlock tool-card plug.....	244

### WORKSHOP HINTS

Caliper made from broken rule.....	190
Jigs for holding frames needs only one clamp.....	190
Slotted sanding block provides better grip.....	190
Wheel disks for model cars are furniture gliders.....	188
Grooved wooden shoe polisher used as sanding block.....	203
Porcelain cemented on metal with glycerine-etching paste.....	204
Utilizing old paintbrushes as glue applicators.....	210
Threading holes in plastics with regular metal-cutting taps.....	217
Insert washers make adjustable wobble saw.....	219
Heated steel plate used to temper small coil springs.....	219
Chamois washed in machine cuts cost and labor.....	219
"Rockers" support engine head to ease bench handling.....	228
Clock spring renews oil can.....	240
Pressman's nonslip finger "cot" is worn without discomfort.....	240
Long level improvised from straightedge.....	244

### MISCELLANEOUS

Simple toy teaches child to differentiate shapes.....	190
Pull toy in eight models.....	191
Vapors of solvents utilized for more economical use.....	194
Painting over varnish or enamel with oil-base paint.....	198
Plan of the Month.....	200
Lawn spreader containing sand used to treat icy sidewalks.....	210
New uses for disk cement.....	217
Oil-drum cooler for stationary engine control temperature.....	221
Baffle cast in concrete chute checks drainage-ditch flow.....	226
Draftsman's perspective liner from yardstick.....	233
Glass cover protects price list.....	240
Pipe-joint sealing compounds.....	240
Coupling and extension help thread short pipe nipples.....	241
Grooved sawhorse permits easy cutting of building paper.....	245

## Radio-Television-Electronics

TV Electronics Today.....	245
Superfidelity home phone has back-loaded cabinet.....	246

## Armor for Hunters

Protection for hunters against stray bullets and errors by other sportsmen is provided by a new plastic body armor. Similar to the armor used by the armed forces in Korea, the plastic plates cover vital organs from the neck to the waist. Though their total weight is only four pounds, the plates will stop .38 and .45-caliber bullets at close range, and 30/06 rifle fire at 275 yards and beyond, according to the manufacturer. They also offer protection against ricochets and buckshot. The plates are slipped into a hunting jacket or vest.



Now IN YOUR OWN HOME Learn

# TELEVISION RADIO ELECTRONICS

*the Amazingly Effective*

## D. T. I. WAY

—with the aid of BOTH  
HOME EQUIPMENT  
and HOME MOVIES

NO PREVIOUS EXPERIENCE NEEDED  
NOW... get  
**EVERYTHING  
YOU NEED**

for real Laboratory-  
type training  
**AT HOME**

Above:  
Work over  
300

fascinating  
experiments  
with this  
equipment

What will mailing the coupon below do for YOU? Just this! You'll find out about one of today's most remarkable... practical ways to prepare to get into America's amazing billion dollar opportunity field of TELEVISION-RADIO-ELECTRONICS. You'll see how to get into fascinating work that pays well... that offers one of America's most promising futures... that enables you to start your own business almost "on a shoe string," if you prefer this to a job opportunity.

And above all, you'll get some GOOD NEWS especially welcomed by men anxious to earn REAL MONEY in this thrilling field. For you'll see that NOW you can get the kind of practical, laboratory-type training so desirable for making real progress in Television-Radio-Electronics AND WITHOUT LEAVING HOME.

You'll see that DeVry Technical Institute sends everything needed to set up your own HOME LABORATORY.

You get and keep the same type of basic electronic equipment used in our modern Chicago Training Laboratories. You get home training that includes

the knowledge and experience gained from training thousands of students first hand in Chicago.

And to top it all, you use DTI's amazingly effective and exclusive home training aid—

**INSTRUCTIVE MOVIES.** But why not get the complete story? Mail coupon today for information-packed literature.

### MODERN LABORATORIES

If you prefer, get all your preparation in our new Chicago Training Laboratories—one of the finest of its kind. Ample instructors, modern equipment. Write for details!

### MILITARY SERVICE!

If you're subject to military service, the information we have for you should prove very helpful. Mail coupon today.

Get this

information-packed publication

# FREE!

*Mail Coupon Today*

DEVRY TECHNICAL INSTITUTE Dept. PM-2-K  
2532 N. Ashland Avenue, Chicago 14, Ill.

I would like your valuable information-packed publication showing how I can get started toward a good job or my own business in Television-Radio-Electronics.

Name.....Age.....  
Street.....Apt.....  
City.....Zone.....State.....

1. Build over 300 fascinating experiments from 16 BIG SHIPMENTS of Electronic-Radio parts which you KEEP.

2. Build valuable commercial-type test equipment—as shown to the left—which you KEEP. This includes a quality 5 INCH oscilloscope and jewel bearing Multi-Meter—both highly useful for Television work.

3. Build and keep a big 21 INCH TV Set. (D.T.I. offers another home training in Television-Radio-Electronics, but without the TV set.)

4. Use a 16 mm. movie projector and new series of highly instructive movies—a wonderful aid to help you grasp important fundamentals faster... easier... better.

5. Enjoy well-illustrated, easy-to-read lessons with handy FOLD-OUT diagrams.

6. Get an honest-to-goodness EMPLOYMENT SERVICE to help you get a good job after graduating—or assistance in starting your OWN SALES AND SERVICE BUSINESS. Mail coupon today for the complete details.



"ONE OF AMERICA'S FOREMOST TELEVISION TRAINING CENTERS"  
—Established 1931—



**DEVRY TECHNICAL INSTITUTE**  
PREPARED WITH  
**DEFOREST'S TRAINING, INC.**  
CHICAGO 14, ILLINOIS

# Inventors

The following are the usual preliminary steps to take toward patent protection.

You are advised first, to make a disclosure of your invention. Date, sign and have this document witnessed by two or more persons who are capable of understanding your invention. The "Evidence of Invention" form mentioned below, we offer as a convenience in making your disclosure and in starting action leading toward patent protection.

Mail your disclosure to the registered patent attorney or agent whom you select to assist you, together with a letter authorizing him to conduct a

preliminary search among previously granted U. S. patents for similar types of invention. He then prepares for you a report on the probable patentability of your invention and, if the report is favorable, recommends the further course you should take.

This firm is registered to practice before the U. S. Patent Office and is available to assist you in the preparation and prosecution of patent applications. We shall be glad to send you without obligation, the "Evidence of Invention" disclosure form mentioned above and our instructive booklet, "Patent Protection for Inventors".

VICTOR J. EVANS & Co. *Merlin M. Evans*  
REGISTERED PATENT ATTORNEY  
930-B MERLIN BUILDING, WASHINGTON 6, D. C.

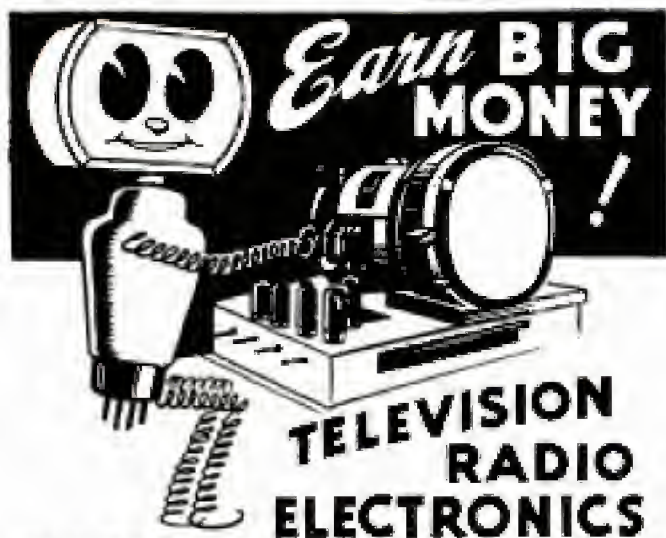

**Earn BIG MONEY!**

**TELEVISION RADIO ELECTRONICS**

Learn at home in your spare time. Cash in on the tremendous demand for trained men. Big pay. Interesting work. Unlimited opportunities. World's fastest growing industry.

**NEW METHOD TEACHES YOU QUICKER, BETTER** Christy Shop-Method Home Training makes everything interesting, easy. The only complete Electronics course. Covers Radar, Sonar, Electronics, Radio and Television. No previous electronics knowledge necessary. You learn by actually working on equipment that you study about. Makes learning fun. Speeds your progress. Helps you understand and remember.

### 19 TRAINING INSTRUMENTS INCLUDED

You build your own Multi-Tester, Oscillator, Signal Tracer, Oscilloscope, Signal Generator, Electronic Timer, Regenerative Radio, Television Receiver (optional), and many other test units. Check circuits, locate and correct troubles, and make hundreds of experiments. All necessary parts and accessories furnished. Earn while you learn by repairing radios and television sets for friends and neighbors.

GET DETAILS . . . SEND FOR FREE BOOK and SAMPLE LESSONS NOW!

CHRISTY TRADES SCHOOL, INC., Dept. T-203, 4804 N. Kedzie Ave., Chicago 25, Ill.

**FREE BOOK**

**CASTING SECRETS REVEALED**



Big money! Cast 1000's of plaques, figurines, etc. with X.L. rubber molds. No exper., little capital req. X.L. rubber pkg. \$3.50, pkg. \$4 (postage extra). Molds, rubber for 3 molds, \$1.50 post. U. S. only. Send 25c (refundable) for 40 pp. fact. catalog.

**HUGE PROFITS! MORE MONEY!**

PLASTIC ARTS STUDIO, Dept. 3,  
3403 S. Madison St., Muncie, Ind.

**Finish HIGH SCHOOL AT HOME**

**Complete 4 Yrs. in 12 Months**

Learn More! Earn More! Enter professional or technical schools. Advance Socially. Live a Happier, Fuller Life. Individual Courses or complete schedule. **WRITE FOR SCHOOL BULLETIN. ACADEMY FOR ADULTS**

30 W. Washington, Dept. PM-204, Chicago, Ill.

**EARN BIG... STEADY MONEY!**  
**Sell Work Uniforms!**

It's quick and easy to EARN BIG MONEY with TOPPS' great new "Panoramic" line that spreads out over 2 feet wide! Styles are big, full-color—swatches are king size. Figures almost pop off the page. Prospects are everywhere—garages, service stations, factories, stores, institutions, almost every business! And they want top-quality, top-styled, long-wearing work uniforms embroidered to advertise. You show the biggest selection in the world—almost unlimited in sizes, fabrics including DuPont's miracle ORLON, colors, styles, embroidery. No wonder TOPPS men take the orders and make the money. One man made \$900.00 on a single sale! Write today for eye-stopping, sales-making "Panoramic" line and complete selling equipment. It's all FREE!

**TOPPS, Dept. 512, Rochester, Ind.**



# HOW TO FIX

Brakes, Clutches, Transmissions, Rear Ends, Carburetors—Yes,  
**ANY PART OF ANY CAR**

USED BY U. S.  
 ARMED  
 FORCES

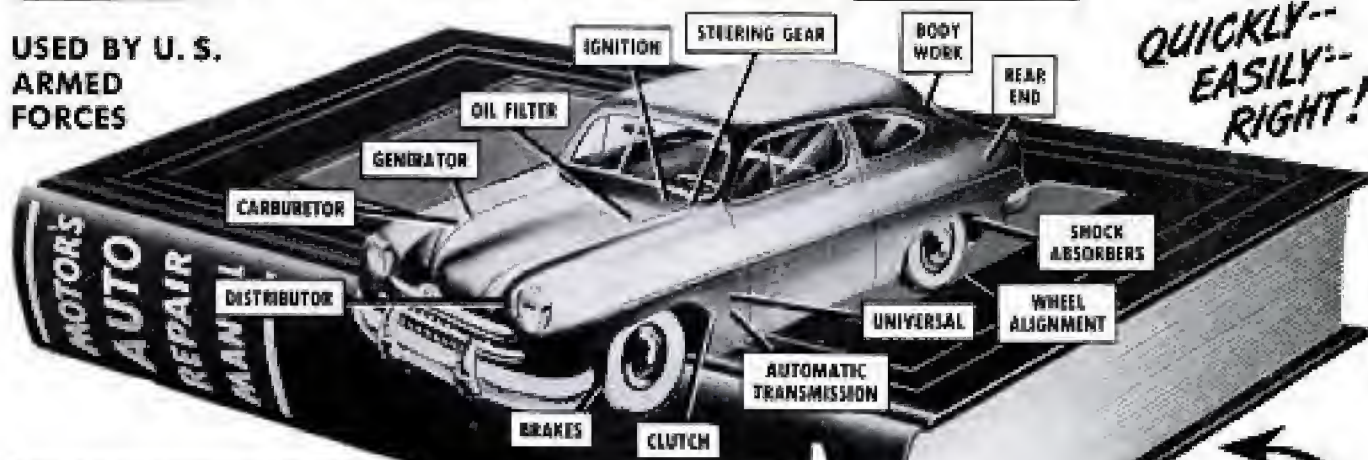

QUICKLY--  
 EASILY--  
 RIGHT!

NOW—Whether You're a Beginner or an Expert Mechanic—You Can "Breeze Through" ANY AUTO REPAIR JOB! MOTOR'S BIG BRAND-NEW AUTO REPAIR MANUAL Shows You HOW—With 2500 PICTURES AND SIMPLE STEP-BY-STEP INSTRUCTIONS.

**Free 7-DAY TRIAL**  
 Return and Pay Nothing  
 If Not Satisfied

## COVERS EVERY JOB ON EVERY CAR BUILT FROM 1935 THRU 1953

YES, it's easy as A-B-C to do any "fix-it" job on any car whether it's a simple carburetor adjustment or a complete overhaul. Just look up the job in the index of MOTOR'S New AUTO REPAIR MANUAL. Turn to pages covering job. Follow the clear, illustrated step-by-step instructions. Presto—the job is done!

No guesswork! MOTOR'S Manual takes nothing for granted. Tells you where to start. What tools to use. Then it leads you easily and quickly through the entire operation!

cuts that will amaze you. No wonder this guide is used by the U. S. Army and Navy! No wonder hundreds of thousands of men call it the "Auto Repair Man's Bible!"

### Meat of Over 189 Official Shop Manuals

Engineers from every automobile plant in America worked out these time-saving procedures for their own motor car line. Now the editors of MOTOR have gathered together this wealth of "Know-How" from over 189 Official Shop Manuals. "boiled it down" into crystal-clear terms in one handy indexed book!

### Some FREE Offer On MOTOR'S Truck and Tractor Manual

Covers EVERY job on EVERY popular make gasoline truck, tractor made from 1935 thru 1953. FREE 7-Day Trial. Check cover for coupon.

Over 2,500 Pictures! So Complete,  
 So Simple, You CAN'T Go Wrong!

BIG BRAND-NEW REVISED Edition. Covers everything you need to know to repair 872 car models—including ALL 1953 CARS. 850 giant pages, 2,500 "This-Is-How" pictures. Over 200 "Quick-Check" charts—more than 37,000 essential repair specifications. Over 227,000 service and repair facts. Instructions and pictures are so clear you can't go wrong!

Even a green beginner mechanic can do a good job. And if you're a top-notch mechanic, you'll find short-

### Try Book FREE 7 Days SEND NO MONEY!

Just mail coupon! When the postman brings book, pay him nothing. First, make it show you what it's got! Unless you agree this is the greatest time-saver and work-saver you've ever seen—return book in 7 days and pay nothing. Mail coupon today! Address: MOTOR Book Dept., Desk 1B, 250 West 55th St., New York 19, N. Y.

Covers 872 Models—All These Makes

Buick	Henry J	Nash Rambler
Cadillac	Hudson	Oldsmobile
Chevrolet	Kaiser	Packard
Chrysler	Lafayette	Plymouth
Cord	La Salle	Pontiac
De Soto	Lincoln	Studebaker
Dodge	Wardner	Terreplane
Ford	Nash	Willys
Franker		



Many Letters of Praise from Users  
 "MOTOR'S Manual paid for itself on the first 2 jobs, and saved me valuable time by eliminating guesswork."  
 —W. SCHROP, Ohio

He Does Job in 30 Min.—Fixed motor weather mechanic had worked on half a day. With your Manual I did it in 30 minutes.  
 —C. AUDREY, Tenn.

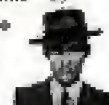

## MAIL COUPON NOW FOR 7-DAY FREE TRIAL

MOTOR BOOK DEPT.  
 Desk 1B, 250 W. 55th St., New York 19, N. Y.

Rush to me at once (check box opposite book you want):

- MOTOR'S New AUTO REPAIR MANUAL. If O.K., I will remit \$1.50 in 7 days, \$5 monthly for 2 months and a final payment of \$6e (plus 5% delivery charge) one month after that. Otherwise I will return the book postpaid in 7 days. (Foreign price, remit \$5 cash with order.)
- MOTOR'S New TRUCK & TRACTOR REPAIR MANUAL. If O.K., I will remit \$2 in 7 days, and \$2 monthly for 2 months, plus 5% delivery charge with final payment. Otherwise I will return book postpaid in 7 days. (Foreign price, remit \$4 cash with order.)

Print Name.....Age.....

Address.....

City.....State.....

Check box and save 34¢ shipping charge by enclosing W.C.M. entire payment of \$5.00 for Auto Repair Manual for \$4 for Truck and Tractor Repair Manual. Same 7-day return-refund privilege applies.

**U.S. GOVERNMENT JOBS**

**Start As High As \$3,795 a Year**  
**Get Ready Now for Next Examinations**  
**In Your Locality**

**Veterans Get Preference**

**City Mail Carriers, Post Office Clerks**

Clerks and Carriers now get \$3,270.00 the first year of regular employment and automatically increase \$100 a year to \$4,070.00. Open to men, women 18 to 50.

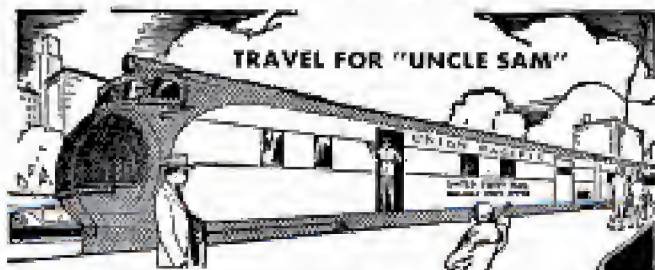

**Railway Postal Clerks**

Railway Postal Clerks get \$3,470.00 the first year regular, being paid on the first and fifteenth of each month. (\$144.58 each pay day.) Their pay is automatically increased yearly to \$4,270.00. Advance may be had to Chief Clerk at \$6,585.00 a year. (\$273.54 each pay day.) Men, 18 to 50, only.

**3 Days On—3 Days Off—Full Pay**

Railway Postal Clerks on long runs usually work 3 days and have 3 days off duty or in the same proportion. During this off duty their pay continues just as though they were working. They travel on a pass when on business. When they grow old, they are retired with a pension.



**Many Other Positions**

Many other positions are obtainable. Rural Carriers—Stenographers—Typists—Assistant Statistical Clerks—Customs Inspectors—Meat Inspectors—etc. Those wishing these positions should qualify at once.

**Get Free List of Positions**

Fill out the following coupon. Tear it off and mail it today—NOW, at once.

Although not government sponsored this investment can result in your getting a big paid government job.

FRANKLIN INSTITUTE, Dept. J-83, Rochester 4, N. Y.

Rush to me, entirely free of charge (1) a full description of U. S. Government Jobs; (2) Free copy of illustrated 30-page book, "How To Get A U. S. Government Job"; (3) List of U. S. Government Jobs; (4) Tell me what to do to qualify for one of these jobs.

Name \_\_\_\_\_

Address \_\_\_\_\_ City \_\_\_\_\_ State \_\_\_\_\_ Zip \_\_\_\_\_

Use This Coupon Before You Mislay It. Write or Print Plainly.

**PRESTO! ANYONE CAN MASTER GLAZE**

GRAYS HARD GLASS-LIKE FINISH  
 EASY TO APPLY  
 PROTECTS THE SURFACE  
 WILL NOT FINGER-MARK  
 NO DIRT FILM AS WITH WAX  
 SEALS THE PORES OF THE SURFACE  
 EASY TO KEEP CLEAN  
 LASTS SIX MONTHS TO A YEAR  
 SAVES YOU MONEY

Car Owners! Meet Master Glaze—the sensationally different luster for new and used cars! Not a wax—not an oil polish—not a paint!—nothing that “smears” over the surface.

**MASTER GLAZE** is a unique discovery—a creamy liquid—quick and easy to apply! Gives a hard, glass-like surface. Even gasoline cannot dull it! Lasts six months to a year! Amazing luster—beautiful, sparkling clean and brilliant! Doesn't finger-mark—doesn't smear! A match box full glazes an entire car. Seals the pores—protects! **NOTHING LIKE IT!**

**FREE SAMPLE**

Just send your name and address to

MASTER GLAZE CO., 7720-781 W. Harwood Ave., Milwaukee, Wis.

**\$750 BUILDS 4 ROOMS & BATH!**

**WHY PAY RENT?** For Seven Hundred Fifty Dollars and 30 days of your spare time, you can build yourself this Beautiful Home. Living Room 11x15, Front bedroom 10x11, Back bedroom 10x12, Kitchen 10x11, Bath 5x6, Hall 5x4. Wind out steel casement windows. Concrete block, stuccoed. Step-by-step illustrated instructions, blueprint and material list \$1.00 ppd. No C.O.D. Homestock guarantee. Economy Home, Dept. C Box 645 Columbus 18, Ohio

**A "GOOD HAND" HELPS YOU SUCCEED!**

**LEARN TO WRITE WELL**

Handwriting quickly improves with our easy-to-understand picture lessons! Put your spare time to good use! send today for  **FREE BOOKLET**, "How to Become a Good Penman," or check volumes wanted below at \$1 each:  Business Writing  Artistic Writing  Card Writing  Brief & Report Writing  Embroidering Alphabets. **COMPLETE SET \$4.50.** Ask for price list of penman's supplies.

**TAMBLYN SCHOOL of PENMANSHIP**  
 S.A. Ziller, Pres., 442 Ridge Bldg., Kansas City, Mo., USA

**'How to MAKE MONEY with Simple CARTOONS'**

A book everyone who likes to draw should have. It is free; no obligation. Simply address  **FREE BOOK**

**CARTOONISTS' EXCHANGE**  
 Dept. 92A Pleasant Hill, Ohio

**Make Big Money At Home**

**BEFORE** **INVISIBLE REWEAVING** **AFTER**

**PAYS UP TO \$10.00 IN AN HOUR!**

Here's your chance for lifelike financial security! Be THE expert **INVISIBLE REWEAVER** in your community! Make hats, burrs, mesh bags, tees, doilies, quilts, all fabrics **DISAPPEAR!** Do it at home—in spare time. Constant demand for towels, cleaners, dept. stores, laundries, individuals—and reweavers are scarce! Profits up to \$10.00 for one hour's work! Make, say to learn with complete, professional home-study courses—first in the field! Write for **FREE** details **TODAY!**

**FABRICON COMPANY, 8342 S. Prairie Ave., Dept. 322, Chicago 19, Ill.**



I'll Train **YOU** at Home in Your Spare Hours for Big Pay Job • Your Own Business • Exceptional Opportunity in

# RADIO-TELEVISION

## ON *New* NO-OBLIGATION PLAN!

**I Send You  
18 BIG  
KITS  
OF RADIO-  
TELEVISION  
EQUIPMENT**



Approved for  
Veterans Under  
the G. I. Bill

**You Have NO MONTHLY  
PAYMENT CONTRACT**

to sign... you pay for your training  
as you learn and earn... **ENROLL NOW!**  
**Be Ready in Little as 10 MONTHS!**

Now you can get into Radio-Television, today's fastest growing big money opportunity field, in months instead of years! My completely new "package unit" training plan prepares you to qualify as a Radio-Television Technician in as short a time as 10 months, or even less! I offer you my training with no monthly payment contract to sign—thus **NO RISK** and **NO OBLIGATION** for you! This is America's finest, most modern and really practical training.

Includes **PN**... **UHF** Television and all the most recent developments. My training gets you ready to handle any practical job in the booming Radio-Television industry. Start your own profitable Radio-Television Service Shop... or accept a fine paying job. I have trained hundreds of successful Radio-Television technicians—and I can train you regardless of lack of previous experience. Mail coupon and get all the facts—**FREE!**

**VALUABLE EQUIPMENT INCLUDED WITH TRAINING**

Much of your Sprayberry Training is actual construction, demonstration and experimentation. You get priceless practical experience this way. You build the 8 tube Sprayberry Short Wave and Broadcast Training Radio Hereby: the Sprayberry Television set, multi-range test meter, signal generator, signal tracer, cathode ray oscilloscope and many other projects. All this equipment is yours to keep. You have practically everything you need to set up your own profitable Radio-Television shop. All lessons and books I send you remain your own property.

**OUR 21st YEAR TRAINING MEN FOR RADIO-TELEVISION**

**Earn Extra Money While You Learn**

All your Sprayberry Training is given **IN YOUR OWN HOME** during your free time. Keep on with your present job and income while learning Radio-Television. With each Sprayberry "Package Training Unit" I include money-making plans and special "Business Builders" for spare time Radio-Television service jobs. New Television stations opening everywhere open big money opportunity for men to install **VHF** antennas—I tell you how! If you expect to be in the Armed Forces later, there is no better preparation than Radio-Television. Mail coupon below... get facts **FREE! No salesman will call.**

**FREE TO YOU 3 BIG RADIO-TELEVISION BOOKS**

**I invite you to get all the facts—**

I want you to have **ALL** the facts—without cost! Rush coupon for my three big Radio-Television books! "How to Make Money in Radio-Television" **PLUS** my new Illustrated Television Bulletin **PLUS** an actual sample Sprayberry Lesson—**ALL FREE!** No obligation and no salesman will call. Mail coupon!

**SPRAYBERRY ACADEMY OF RADIO**  
Dept. 10-F, 311 North Canal Street  
Chicago 5, Illinois

**Mail  
Coupon  
Today!**

**IF YOU ARE  
EXPERIENCED IN RADIO**

Men already in Radio who seek a short intensive **100% TELEVISION** Training with **FULL EQUIPMENT INCLUDED** are invited to check and mail the coupon at the right.

**NO OBLIGATION  
No Salesman  
Will Call**

**SPRAYBERRY ACADEMY OF RADIO**

Dept. 10-F, 311 N. Canal St., Chicago 5, Ill.

Please rush to me all information on your **10-MONTH** Radio-Television Training Plan. I understand this does not obligate me and no salesman will call. Include 3 books **FREE!**

Name..... Age.....

Address.....

City..... Zone..... State.....

Are you Experienced?  No Experience

## Genuine DIAMONDS Direct from N. Y. Leading Pawnbroker



### In Latest Style Mountings From \$25 to \$5,000 Remarkable Savings

Diamonds never get old! Kaskel's, New York's leading pawnbroker since 1882, have originated a novel plan for you to enjoy great savings on diamonds reset in brand new 14 Kt. gold or platinum mountings. Kaskel's plan is simple. They fine-comb the many outlets where diamonds can be secured at much lower than regular wholesale prices. These markets uncover first grade diamonds at amazingly low bargain prices. Kaskel's resets them into beautiful diamond rings, diamond bracelets, diamond pins, diamond earrings, diamond watches . . . AND . . . Kaskel's grades them for you according to nationally accepted standards. These unusual beauties are yours for a fraction of the usual market cost. You take no risk. You are 100% protected by a written bond and a money back guarantee. You can see your selection before you buy. Any size genuine diamond can be yours on a pay as you like lay-away plan. There are no extra charges. Kaskel even pays the excise tax.

## FREE BIG CATALOG Diamond Advice FREE!

Send today for the big illustrated catalog just off the press. It illustrates many wonderful diamond bargains. All in most fashionable, up to the minute mountings, of 14 Kt. gold or platinum. You also get important advice about diamonds that is in itself a diamond buying safe-guard and education. Send coupon below for your copy today and learn all the facts which includes Kaskel's special pay as you like lay-away plan. There's no obligation. SEND COUPON TODAY.

References: Dun & Bradstreet, Jewelers Board of Trade, or your own bank.

KASKEL'S, Dept. 407-B (Diamond  
9 Columbus Avenue Specialists  
New York 23, New York since 1882)

Send FREE CATALOG and advice about DIAMONDS without obligation.

Name.....

Address.....

City..... State.....

## Shrinks Hemorrhoids Without Surgery

Science Finds Healing Substance That  
Relieves Pain—Shrinks Hemorrhoids

Science has found a healing substance that shrinks hemorrhoids, stops pain promptly, ends bleeding — without surgery. Doctors report actual shrinking of hemorrhoids. Sufferers say, "Hemorrhoids have ceased to be a problem." The secret is Bio-Dyne® — already widely used for healing injured tissue. This substance is now available in a hemorrhoid ointment called Preparation H\*. Ask your druggist for Preparation H. Money back guarantee. \*Trade Mark

### TASOPE PHOTO-ENGRAVING PLANTS



Material Cost  
Of This Cut 3/4"  
Selling Price  
\$1.00 And Up

Establish your own profitable PHOTO-ENGRAVING business. Make cuts for newspapers, printers, and advertisers. Make etched name plates, plaques etc. Instructions furnished, no experience necessary. Sold direct from factory since 1931. First five hundred cuts sold locally or by mail will pay for plant and pay you well for your time. Write for FREE catalog.

TASOPE, DEPT. PM2, AURORA, MO.

### Become a Doctor of PSYCHOLOGY

Win the degree of Ps.D. Learn the secret of contentment, happiness. Solve mental worries. Experience the revelation of truth. Chartered college. Individual help. Write for FREE book. COLLEGE OF UNIVERSAL TRUTH, 5036-B Broadway, Chicago.

**BUY IT WHOLESALE!**

GET UP TO 40% OFF

Start a Buying Service at Home. Start up. Get the same merchandise for self and clients up to 40% less than retail price. Sales easy as you can give sizable discounts. Still make big commissions. Post Card Buying Free Copy

**AMERICAN BUYERS SERVICE**

631-B Linden Ave., Buffalo 16, N. Y.

### LEARN LOCKSMITHING

Learn this fascinating, profitable trade from experts in your spare time at home! Age or physical handicap no disadvantage. Year around, steady income. Full or part time. Practical, illustrated lessons. You can make money even while learning! All materials and special tools supplied without extra charge.

**INSTITUTE OF LOCKSMITHING, Dept. P-51**  
15 PARK AVENUE RUTHERFORD, N. J.  
Lic. by N.J. State Board of Education  
Approved for Veterans

send for  
**FREE**  
**BOOKLET**

### Broken or Loose FALSE PLATE?

**Fix it Yourself EASILY in a Few Minutes**

Your plates may become broken or loose just when you need them most. With FIX-IT-KIT you can repair your own broken plates. Also tightens loose fitting plates, easily. Get permanent comfort with professional material. Complete instructions. Satisfaction guaranteed or your money refunded. Order Now at a new low price only \$2.98 postpaid — or sent C.O.D.

Make  
Plates Like New

DENT-FIX DENTAL PRODUCTS, Box 674, Dept. PM-2, Kansas City 8, Mo.

### SAY YOU SAW IT IN POPULAR MECHANICS

### Learn BAKING At Home

Baking is one of America's high industries in wages. Nearly depression-proof. Thorough basic home course lays sound foundation. If you have aptitude, write for FREE BOOKLET. "Opportunities in Commercial Baking."

**NATIONAL BAKING SCHOOL**  
Dept. 1392 825 Diversey Pkwy. Chicago 14



"Family and friends surprised at my rapid progress." — Beattie Mae Clay, Center, Tex.



"Didn't know a note. Now I play for dances." — Bessie McCombs, B.C., Can.



"Thanks for helping me play accordeon professionally." — J. G. Collier, Milledge, Ga.



"Wonderful success playing accordeon." — Mrs. C. E. Godley, Seattle, Wash.



"Got my start with U.S. School of Music." — Lawrence Wolk, Famous band leader.



"Can't express how happy I am. Play for parties, entertainers!" — Cora Duke, Va.



"Face as falling off leg. Life-long dream being fulfilled!" — Mrs. P. B. Jones, Utah.



"Now play better than students who took lessons from teachers." — M. Saint-Andre, Montreal.



"Enjoyed every hour of guitar course. Now invited to parties, dances." — H. Hopkins, N. Y.



"A friend said, 'Sounds like you've been playing for years!'" — L. Gunn, Oakland, Cal.



"Am playing pieces. Family very proud." — Virginia Hill, Hillside, N. J.



"In a short time I could play several pieces. Everyone amazed!" — Mrs. J. P. Perry, W. Va.



"My friends amazed! Now entertain at parties!" — S. Mason, Mt. Vernon, Tenn.

Everyone's Talking About This Amazingly Easy Way To

PLAY MUSIC RIGHT AWAY!

900,000

Yes, 900,000 people have turned to this simple way to make their dream of playing music come true! FREE BOOK tells all about our "Easy As A-B-C" Way

No wonder everyone's talking about it! Here is an EASY way to learn to play the piano, accordion, guitar—or any other instrument. And not by any "trick" method—but properly, by note. You'll start playing simple pieces RIGHT AWAY. And soon you'll be playing so confidently that your friends will be amazed.

No boring scales and exercises. Even if you don't know a single note now, you'll "start right in on simple pieces." It's all so clearly explained—so EASY to understand—that even children "catch on" quickly.

**No Special "Talent" Needed**

No special "talent" needed. And you learn right at home, in spare time. Costs only a few cents per lesson, including sheet music.

**Why Keep on Missing These Joys?**

Let this famous method bring the pleasures of music into YOUR life! Good times. New friends. Gay parties. Extra money from playing or teaching. Possibly even a musical career. Best of all, the deep personal satisfaction of being able to make your own music.



Meet Mildred Gade of Houston, Tex. She and some friends so enthusiastic about this simple way that they've ALL taken it up!

**Free Book AND FREE LESSON-SAMPLE**



Mail coupon below for valuable 36-page FREE BOOK — and free Lesson-Sample. No obligation; no salesman will call on you. U. S. SCHOOL OF MUSIC, Studio 302, Port Washington, N. Y.



MAKES LEARNING MUSIC SO EASY — IT'S ALMOST LIKE MAGIC!  
 I DIDN'T KNOW A SINGLE NOTE WHEN I STARTED!  
 WHAT I LIKE IS THE LOW COST -- JUST A FEW CENTS A LESSON!  
 AND IT'S SO MUCH FUN--YOU START RIGHT OUT PLAYING REAL PIECES!



**U. S. SCHOOL OF MUSIC**  
 Studio 302, Port Washington, N. Y.

Send me FREE BOOK and FREE Lesson-Sample. No obligation—and no salesman is to call upon me. I'm interested in playing

Name (Instrument) \_\_\_\_\_  
 No  do NOT—have instrument now.

Name \_\_\_\_\_  
 Address \_\_\_\_\_  
 City \_\_\_\_\_ State \_\_\_\_\_  
 Please state Zone No. (if any)

# BECOME A Mechanical Engineer

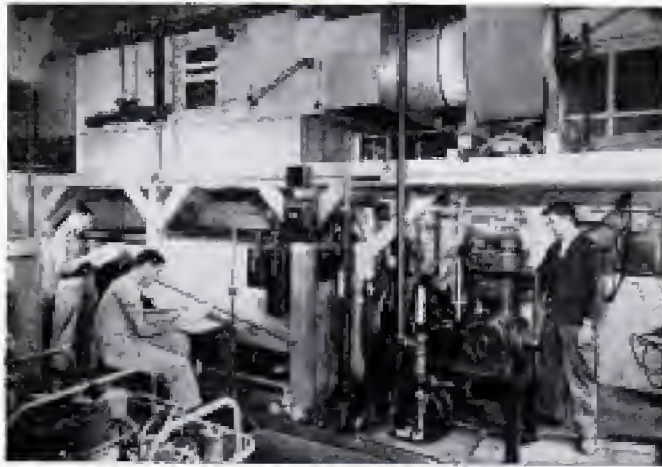

## B. S. Degree in 36 months



Mechanical Engineers hold respected, well-paying, and highly interesting jobs in many fields of industry. You can prepare now for a secure future as an engineer or engineering technician by studying here, in this leading industrial center.

### Check from these Courses

#### ENGINEERING 36 months, Bachelor of Science Degree

- Mechanical Engineering with a major in Design, Metal Fabrication or Plant Engineering.
- Electrical Engineering with a major in Electronics or Power.

#### SERVICE 6 to 12 months

- Electricity ● Heating
- Refrigeration ● Welding

#### TECHNICIAN 12 to 18 months

- Radio and Television
- Electronics
- Electrical Power
- Mechanical Technician
- Air Conditioning
- Welding

General preparatory course — 3 months.

TERMS OPEN APRIL, JULY, SEPTEMBER, JANUARY

Faculty of specialists. Over 50,000 former students. Annual enrollment from 48 states and 23 overseas countries. Non-profit. 51st year. Military, Practical or Academic training evaluated for advanced credit. Approved for Veterans Training. Write for details today.

## MILWAUKEE SCHOOL OF ENGINEERING

MILWAUKEE SCHOOL OF ENGINEERING  
Dept. PM-254, 1025 N. Milwaukee  
Milwaukee 1, Wisconsin

Send free "Your Career" booklet.

I am also interested in:

name of course

Name.....App.....

Address.....

City.....Zone.....State.....

If veteran, indicate date of discharge.....



## 100 YEAR OLD U. S. STAMPS



We will send "On Approval" all United States stamps, even those over 100 years old. We will also send "On Approval" all foreign stamps in singles and sets, including such famous issues as Coronations, Roosevelts, etc. Ours is the only stamp house able to render such service. Just send 10c for our introductory bargain of 50 different U.S. stamps and fascinating stamp literature.

### GLOBUS STAMP CO.

258 — 4th Ave. New York 10, N.Y. Dept. 213

## RUPTURE!

An amazing Air-Cushion Invention allows body freedom at work or play. Light, neat, cool, sanitary. Durable, cheap. Day and night protection helps Nature support weakened muscles gently but surely. No risk. Sent on Trial! Write NOW for free Booklet and Proof of Results. All correspondence confidential.

Brooks Company, 373-C State St., Marshall, Mich.



## Secrets of VENTRILOQUISM Now Revealed!



Easy to learn in 60 to 90 days with our Home Study Course. RESULTS GUARANTEED. Make Money! Be Popular! Have Fun! Big Opportunity! Radio, Television, Stage Appearances! For FREE Information regarding price and terms, WRITE, You must state your age, Home Address, U.S. FRED MAHER SCHOOL OF VENTRILOQUISM Box 36, Studio B, Kensington Station Detroit 24, Michigan



## Wild Life Films

Exciting dramatic action in the natural habitat of animals of forest and plains, 8 mm or 16 mm in beautiful color or B & W. Also 2" x 2" color slides. Write for free illustrated literature.

### WILD LIFE FILMS

5151 Strohm Ave., Rm. 2B, No. Hollywood, Calif.

## Say You Saw It in Popular Mechanics

MAKE EXTRA MONEY

## PLASTICS

LEARN AT HOME

LEARN HOW TO MAKE fast-selling PLASTIC NOVELTIES FURNITURE JEWELRY



There are RICH OPPORTUNITIES for MEN and WOMEN with "know-how" in Plastics. Interstate's new Plastics course tells and shows how to make hundreds of fast selling items out of Plastics. Gives complete training in fabrication, casting, lamination, molding, internal carving, etc. In simple, easy, step-by-step language and pictures. Plastics and Fabricating Kits for 13 valuable Plastic items come with training at no extra cost. START A PLASTICS BUSINESS OF YOUR OWN. No other industry holds such promise for the future. You can make big money manufacturing novelties, toys, signs, etc., in your own home in spare or full time. Don't wait! Learn NOW how Interstate's Plastics Training qualifies you for success in the Plastics field.

PLASTICS AND SUPPLIES FURNISHED FOR 23 VALUABLE PRODUCTS

INTERSTATE TRAINING SERVICE  
Dept. C-3-B Portland 13, Oregon



# HERE'S A READY-MADE FUTURE FOR YOU

MILLIONS OF HOMES IN U.S. HAVE 6-12 SMALL APPLIANCES & MILLIONS MORE SOLD EVERY YEAR. - MILLIONS NEED REPAIR NOW WITH THE NEED INCREASING DAILY!

Start Your own Business IN

## ELECTRICAL APPLIANCE REPAIRING

### EARN WHILE YOU LEARN

Only had your course a few short weeks and have already made \$800.00. Going to quit my job paying \$250.00 straight salary to operate my own business. — J. D. S., St. Louis, Mo.

Make \$15.00 Saturdays and more. Am only able to operate in my spare time. It is just what a mechanical minded man needs. — G.O.P., Thomasville, Ga.



### IN YOUR OWN KITCHEN, BASEMENT OR GARAGE

Learn at home in your spare time this fascinating big paying profession.

If you are mechanically inclined, can hold and use tools, we can give you the training and time saving kits that will enable you to . . . Command More Money At Work . . . A Better Paying Job Elsewhere . . . Or A Business Of Your Own!



### 3 EASY STEPS

- 1 We send you the "CHRISTY" Electronic Kit. A multi-purpose trouble tracer, indicates current consumption, shorts, breaks, etc.
- 2 We teach you Electrical Appliance Repairing with easy Indexed Illustrated Manuals. The Easy-To-Remember-Way.
- 3 We show you How to Get Business and Keep Business Coming to you.

New Shop Method Home Training teaches you both the technical and practical side of Electricity by having you work with your hands, Building, Testing, Repairing. All instruction manuals are written in easy-to-understand language chock full of hundreds of detailed photos and drawings.

We show you how to quickly locate the trouble, how to fix it and what to charge. ALSO, how to solicit business and keep business coming to you!

**\$5.00 TO \$6.00 AN HOUR**

Often charged for making ordinary repairs. We show you how to repair refrigerators, vacuum cleaners, washing machines, toasters, etc.



WE GIVE YOU THIS ELECTRONIC KIT TROUBLE FINDER



### SEND FOR FREE BOOK!

CHRISTY TRADES SCHOOL, Dept. D-2703  
4804 N. Kedzie Ave., Chicago 25, Ill.

Please send me FREE Illustrated Book on Electrical Appliance Repairing and special form for mailing later from earnings.

NAME \_\_\_\_\_ AGE \_\_\_\_\_

ADDRESS \_\_\_\_\_

CITY \_\_\_\_\_ Zone \_\_\_\_\_ State \_\_\_\_\_

## FREE BOOK AND ACTUAL SAMPLE

Screen Print, Dept. 22  
1010 S. Los Angeles St.  
Los Angeles 15, California  
Dear Mr. Hancock: Please rush me FREE BOOK,  
ACTUAL SAMPLES, and your amazing new PRINTING PLAN

Name \_\_\_\_\_  
Address \_\_\_\_\_  
City \_\_\_\_\_ State \_\_\_\_\_

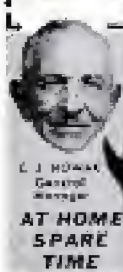

IT'S AMAZING! I'll show you  
how to make up to \$12.50 per hour  
**PRINTING**  
WITHOUT A PRINTING PRESS

**AMAZING NEW COLOR PRINTING METHOD**  
A fascinating new miracle-way to print—a secret method that lets you print colorful signs, posters, banners, drapes, wallpaper, flags, glass, fabrics—ANYTHING without an expensive printing press or costly equipment. This new process is revolutionizing the entire printing industry—it's one of America's fastest-growing businesses—it's your "chance of a lifetime" to make Big Money Now! Be the FIRST in your area to profit. The secret can be yours—just mail the coupon above today!

**EASY TO LEARN! NO EXPERIENCE NECESSARY!**  
Simple (amazing) method! No artistic ability needed. It's possible for anyone (young or old) to make up to \$20 PER WEEK printing in SPARE TIME alone—AT HOME!  
**START YOUR OWN BUSINESS—BE YOUR OWN BOSS**  
Wouldn't you be happy if you could take only one hour of your time and \$1.00 worth of materials—and sell your printing for \$15 or more. It's that easy! It's amazing! Your home can be your office—No office because there's a huge demand everywhere. **GOVERNMENT CONTRACTS AVAILABLE TO BID.** Biggest opportunity in America—make you eligible to receive all CONFIDENTIAL FACTS—Mail coupon today!

### SCREEN-PRINT

1010 S. Los Angeles St., Los Angeles 15, California



Print paper of all kinds

PRINT BANNERS

PRINT FABRICS

PRINT INSTRUMENTS

PRINT SIGNS FOR SALE

YOU CAN PRINT ANYTHING WITH



T3

## Make Money Manufacturing Concrete Drain Tile



Manufacturers of concrete drain tile are in the driver's seat. Why? Because their basic costs are not burdened by freight, distribution and breakage costs—items which the clay tile people have to pass along. Net results: concrete tile can sell for less, yet show a generous profit.

The market is big—and getting bigger. Not only because of increased farm drainage, but also because drain tile are needed in home building, reclamation projects, highway construction, and many other purposes.

Tile made on the Champion are outstanding in quality—dense, strong, uniform and truly round. All sizes up to 12" diameter. Easy to make, because the Champion Machine is simple, compact, and requires no skilled labor. Business is a low-investment opportunity, with equipment available on terms. Write for catalog.



CONCRETE EQUIPMENT CO.  
522 Ottawa Ave., Holland, Mich.

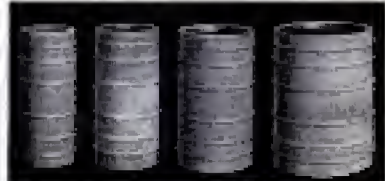

## Catalog of 3000 Novelties 10c

Send 10c for amazing catalog of novelties, live animals, scientific supplies, hobbies, funmakers, planes & boats, looms, magic tricks, joke articles, unusual seeds, gadget time-savers, cameras, optical goods, projectors, movies, lucky jewelry, religious novelties, disguises, musical instruments, stamps, coins, puzzles, fortune tellers, radios, auto & bike accessories, telescopes, magnifiers, compasses, banks, smokers' gadgets, artists' supplies, printing sets, engines, motors, shockers, knives, billfolds, guns, rifles, sports, books, games, plants, etc. Send name, address & 10c to:

JOHNSON SMITH & CO., Dept. 786, Detroit 7, Michigan

Say You Saw It in Popular Mechanics

## CASH Every Day

Just Showing Car Owners Exciting New

## AUTO SEAT COVERS

Easy to Earn Up to \$16.50

A DAY and Even  
More in Spare  
Time!

EXTRA! Your Own Seat  
Covers as Bonus!



• Stop fooling around with hard to sell items . . . get the exciting new Key Auto Seat Cover Line and step into BIG MONEY overnight! Every car owner is your red hot prospect

there are thousands near your home! Get easy, big profit orders full or spare time. Expertly tailored, perfect fitting Key Plastic

Seat Covers for any make or model car. **EXCLUSIVE NEW MATERIALS AND PATTERNS;** new ideas galore, including sensational new BAMBOO fabric shown above. Smash all objections, write on-the-spot orders the instant you quote KEY'S amazing low prices. No experience needed. **NO INVESTMENT.** Just rush coupon with name and address; we'll send big FREE self-selling sales outfit at once. Just show it to pocket up to \$16.50 on orders that take only moments to write. **EXTRA! Bonus Seat Covers . . . our gift to you. Mail coupon NOW!**

### MAIL COUPON—GET BIG FREE OUTFIT

KEY PRODUCTS CORP., Dept. 442  
800 N. Clark St., Chicago 10, Ill.

Rush FREE KEY Sample outfit at once. I'm ready to start!

Name \_\_\_\_\_  
Address \_\_\_\_\_  
Town \_\_\_\_\_ Zone \_\_\_\_\_ State \_\_\_\_\_

## Learn ACCOUNTING Business Administration

Bookkeeping, secretarial and allied subjects at home in your spare time or attend nationally approved resident school. Write for FREE Success Book giving complete details on courses, plans, rates and employment opportunities. G.I. approved.

Hills BUSINESS UNIVERSITY AND  
EXTENSION SCHOOL  
619 W. MAIN ST. OKLAHOMA CITY 2, OKLAHOMA

## ANALYZE HANDWRITING

MORE INCOME. Prestige. Success. Fascinating unproved profession-business, full or spare time. FREE illustrated lesson & Year Book shows how men and women in home, business and professions analyze handwriting to understand people. **MAKE MONEY.** FREE lesson and information about unusual opportunities if over 21.

I. G. A. S., Inc., 901 Wilhoit Bldg., Springfield, Mo.

## ELECTRIFY your SEWING MACHINE

NEW LOW PRICE! \$9.95 1 YEAR GUARANTEE

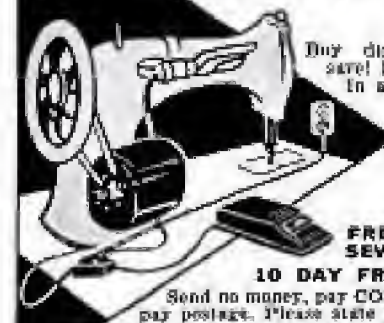

Buy direct from manufacturer and save! Kit comes fully wired, installed in a JIG. Fits all machines! You get ALL-NEW PARTS

- Motor & Bracket
- AC-DC 110V 60c
- Multi-speed foot control
- Card set & block
- Easy instructions
- Steel pulley & belt

FREE . . . Reg. \$2.95 chrome SEW-LITE given with every kit.

10 DAY FREE TRIAL—ORDER NOW!

Send no money, pay COD or send money order and we'll pay postage. Please state whether wheel on your machine turns toward you or away from you. Shipping wt. 6 lbs.

SENIOR SEWING MACHINE CO.

Box 147

Dept. PM53

Brooklyn 8, N. Y.

# NOW... Start Fixing TV and Radio Sets RIGHT AWAY

...EVEN IF YOU NEVER FIXED A LAMP OR DOOR BELL BEFORE!

McGraw-Hill's Amazing New Low-Cost Course Skips Confusing "Theories" and "Formulas," Tells "How-to-do-it" in PLAIN ENGLISH!

WHY hasn't somebody done this BEFORE? That's what you'll exclaim the minute you start browsing through this amazing new one-volume course in radio and TV repair.

For here at last a well-known EXPERT has found a way to tell you in PLAIN ENGLISH how to fix almost ANY radio or television set. (And he even tells you where you can go to have the extra-tough jobs done FOR you . . . at reduced professional rates.) Right from the very first chapters you can start doing simple repairs . . . and before you're HALF WAY through the course, you can fix HALF the television and radio sets that you encounter. In just a few weeks you can tackle your own and friends' sets . . . get a service shop job . . . even start your own money-making business right in your own home.

### Why It's So EASY to Understand

No complicated electronic formulas . . . no algebra . . . no laboratory experiments . . . no technical double-talk. Instead you deal only with the things that go wrong in sets—how to recognize the trouble—and what to do about it. "Easy as A-B-C" directions and 700 clear photos, diagrams, and drawings show you exactly WHAT and HOW to fix, step-by-step.

The author is Associate Editor of Electronics Magazine. He's a long-recognized expert—not only on radio and TV—but also on making technical subjects easily understood by the average reader. He has spent FOUR years making this one-volume course so practical and easy-to-understand that even an "unhandy" man who never fixed a door bell before will find the going easy.

Here's everything you need to know about where and how to buy



### Prove It on Your Own Set

Save \$50 to \$100 a year just in installing, repairing, and servicing your own TV set. Book tells which controls to adjust or tubes to replace if picture is entirely dark—blurred—split—distorted—off center—titled—jiggles and weaves—too pale—too black—jitters—snow effects—drifts—etc., etc.

tubes and parts, where and how to get an official circuit diagram for any receiver; how to choose and use basic tools; how to test tubes WITHOUT a tube tester; how to use 58 common TV controls; how to "diagnose" and "cure" common radio and TV troubles; how to fix loudspeakers, phone pickups; how to install and check antennas; and much, much more.

### SEND NO MONEY

Examine this book for 10 days BEFORE you decide if you wish to own it. Try it out FREE on your own or a neighbor's set. See what a "breeder" it makes nearly every repair job. Make it pay for itself in 10 days or don't keep it! Mail coupon to: McGraw-Hill Book Co., Inc., Dept. PM-2, 327 West 41st St., New York 36, N. Y.

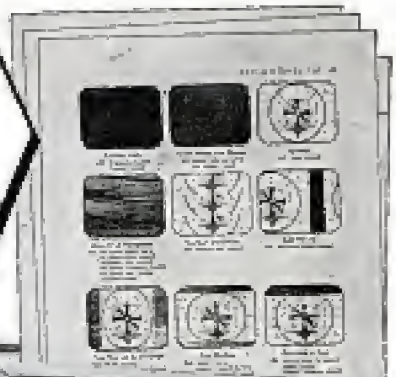

## TELEVISION AND RADIO REPAIRING

### PARTIAL CONTENTS

How to Remove and Replace Tubes • Testing Tubes without a Tester • Using a Tube Tester • Power-Supply Troubles • How to Test and Replace Resistors, Controls, Switches, Condensers, Cords, Transformers • Loudspeakers • Phone Pickups and Needles • Antennas . . . MUCH MORE

### Tells HOW TO "Cash In" ON THE BIG DEMAND FOR RADIO-TV REPAIRMEN

Over 25 million TV sets over 100 million radios! Make nice extra money just fixing sets for friends and neighbors in your spare time . . . or start your own full-time repair business. Book tells exactly how to get started; which tubes to stock; how to make a service call. Actually start fixing sets and making money before you're half-way through book.



### FREE 10-DAY TRIAL COUPON

McGraw-Hill Book Co., Inc., Dept. PM-2, 327 West 41st St., New York 36, N. Y.

Please send me, for 10 days' FREE EXAMINATION, your one-volume course in "Television and Radio Repairing," by John Markus. If not delighted, I may return book, pay nothing. Otherwise, I will send only \$1.85 plus few cents delivery; then 8 monthly installments of \$2.00 each.

Name.....

Address.....

City..... Zone..... State..... PM-2

SAVE MONEY. Check here if enclosing full price of \$7.95 with coupon. Then WE will pay for delivery. Same 10-day return privilege applies.

### Book Tells Where to Look for Bad Tube If:

- No picture; no raster\*: no sound. Picture and raster do not fill screen; sound OK.
- No picture; raster OK; no sound. Picture drifts up or down but not sideways; raster OK; sound OK.
- No picture; no raster; sound OK. Picture muggy and gray; raster OK; sound OK.
- No picture; raster OK; sound OK. Picture and raster OK; sound OK.
- Picture jittery, double image; raster OK; sound OK. Snow on all channels; raster OK; sound weak.
- Snow on all channels; raster OK; sound OK. . . . PLUS 29 OTHER COMMON TV TROUBLES

(\*"Raster" is obtained by tuning to channel having no program.)

**AUTO BODY MEN**  
 Expert coach, paint and metal work.  
 High earnings. Open air. Horvath  
 Motors, 1012 Chicago St., Evanston,  
 Illinois 44123.

**AUTO BODY FENDER MAN**  
 Ideal working conditions. High  
 earnings. Horvath Motors, 1012  
 Chicago St., Evanston, Ill. 44123.

**Auto Body Craftsmen WANTED!**

**AUTO BODY MEN**  
 To work on cars and trucks.  
 Lincoln 6-2227.

**Learn This Craft - Earn Big Money**

Look at the Help Wanted ads in your paper. The billion-dollar auto repair trade needs trained men NOW! The demand is big... pay is big... opportunities are great. You have a chance to grow with this growing trade, perhaps set up your own profitable shop.

**CASH IN ON YOUR SPARE TIME!**

You can begin your Auto Body & Fender Training at home in spare time with the proven UEI plan. You learn about appearance reconditioning, metalwork, painting, welding, other practical phases without leaving your present job. Then get actual practice in our large, well-equipped shops, repairing wrecked cars under the guidance of skilled instructors. Get FREE book and all the facts by sending coupon NOW!

UTILITIES ENGINEERING INSTITUTE 2123 Sheffield Ave., Dept. XC-27  
 Auto-Craft Div., Chicago 14, Ill.

**MAIL TODAY FOR FREE FACTS**

**UEI**  
 has been training men for industry since 1927.

Auto-Craft Div.  
 UTILITIES ENGINEERING INSTITUTE  
 2123 Sheffield Ave., Dept. XC-27, Chicago 14, Ill.  
 YES! Rush FREE Book and All Facts on Auto Body & Fender Repair Training.

Name \_\_\_\_\_ Age \_\_\_\_\_

Address \_\_\_\_\_

City \_\_\_\_\_ Zone or County \_\_\_\_\_ State \_\_\_\_\_

Check for special information if under 17.

**DRAFTING pays BIG MONEY!**

Draftsmen earn more, enjoy pleasant working conditions. Get into DRAFTING and Blue-Printing. The starting point of all production. Trained Draftsmen are needed everywhere. Machines can never replace the draftsman.

**LEARN AT HOME IN SPARE TIME**  
 Revolutionary new method teaches you quickly the hows and whys of Mechanical, Structural, Machine, Architectural, etc. Drafting. You are sent professional drafting instruments, drafting equipment, portable drafting table, etc., at no extra cost. You learn by making actual drawings.

**BIG MONEY... ADVANCEMENT OPPORTUNITIES**  
 offered trained draftsmen. Drafting is light, pleasant work, paying big salaries. In a stepping stone to top managerial jobs. The draftsman plans the World of Tomorrow. That is why drafting is such interesting work.

**OWN YOUR OWN DRAFTING FIRM**  
 The investment requirement is small, the earning possibilities great. Many draftsmen eventually branch out into manufacturing the products they created. Learn of the opportunities in Drafting.

**MAIL THIS COUPON TODAY!**

CHRISTY TRADES SCHOOL, Dept. DB-2403  
 4804 N. Kedzie Ave., Chicago 25

Mail at once your big FREE book on Drafting and Blue-Printing. Tell us how your Home Training and Professional Drafting Instruments, Portable Drafting Table, Drafting Equipment, etc. can be had on a PAY AS YOU LEARN plan.

NAME \_\_\_\_\_ Age \_\_\_\_\_

ADDRESS \_\_\_\_\_ CITY \_\_\_\_\_ STATE \_\_\_\_\_

**321 DIFFERENT STAMPS**  
 FROM ALL OVER THE WORLD  
 for only 25¢

plus FREE Booklet on Stamp Collecting

Big valuable imported collection of 321 different stamps from dozens of hard-to-get countries! Regular \$3.50 value — yet all yours for only 25¢ to introduce our Bargain Approvals. Included, FREE, helpful booklet on Stamp Collecting — shows you how to identify stamps, Money back if not delighted. Send 25¢ today. Ask for Lot F0-12.

**MONACO** — Pope Pius triangles  
**SO. MOLUCCAS** — General MacArthur set.  
**UNITED NATIONS** — first 3 issues — historic set!

**ZENITH CO., 81 WILLOUGHBY ST., BROOKLYN 1, N. Y.**

**RUPTURED?**  
 Get Relief This Proven Way

Why try to worry along with trusses that gouge your flesh — press heavily on hips and spine — enlarge opening — fail to hold rupture? You need the Cluthe. No leg-straps or cutting belts. Automatic adjustable pad holds at real opening — follows every body movement with instant increased support in case of strain. Cannot slip whether at work or play. Light. Waterproof. Can be worn in bath. Send for amazing FREE book, "Advice To Ruptured" and details of liberal truthful 60-day trial offer. Also endorsements from grateful users in your neighborhood. Write:

**CLUTHE SONS, Dept. 31, Bloomfield, New Jersey.**

**How to Make Money with Simple Cartoons?**

A book everyone who likes to draw should have. It is free; no obligation. Simply address **FREE BOOK**

**CARTOONISTS' EXCHANGE**  
 Dept. 92D Pleasant Hill, Ohio

**BOYS BUILD YOUR OWN CRYSTAL RADIO**

It's easy and lots of fun to build your own crystal radio set. You need no batteries or tubes when you use a "Melomite" Crystal and detector. Wonderful performance. "Melomite" crystal and detector with instructions and plans for building your own Crystal radio set — All for only 50¢ post-paid. Rush your order today, immediate delivery.

**ALVA ALLEN RADIO, Dept. PM-52, Clinton, Mo.**

**FREE Big NURSERY CATALOG**  
 with 999 special offers

Send for America's most unusual nursery catalog. Special dollar-saving collections. Old favorites... rare varieties. 48 value-packed pages. Roses, mums, bulbs, fruit, shrubs, etc. — all guaranteed, all gov't inspected. Write today.

**Spring Hill Nurseries, Dept. L-31, Tipp City, Ohio**

**New MIRACLE WALL CLEANER**

**QUICK EASY** Saves Costly Redecorating

AMAZING INVENTION. Eliminates difficult scrubbing, sanding and more. No mess — no sticky "dough" — no red, swollen hands. No more dangerous step-ladders. Literally erases dirt like magic from wallpaper, Painted Walls, Ceilings, Window Shades. Take orders from friends! Earn money! Act now!

**SAMPLES FOR TRIAL** Sample offer sent immediately to all who send name at once. Henry. Postcard will do. SEND NO MONEY — just your name. **KRISTEE CO., Dept. 874, AKRON 6, OHIO**



No matter where you live  
or what you are doing now...

# I WILL TRAIN YOU FOR A BIG PAY JOB IN TELEVISION

L. C. Lane, B.S., M.A.  
President, Radio-Television Training Association,  
Executive Director,  
Pierce School of Radio-Television.

## CIVILIANS! VETERANS!

Thousands of new jobs in TV are opening up in every state as new stations go on the air. You too can take your place in America's booming TELEVISION and Electronics Industry. Enjoy the success and happiness you always wanted out of life! Now prepare for a life-time career as a trained TV TECHNICIAN, often within months... using the same successful "learn-by-doing" home study methods that have helped hundreds of men with **NO PREVIOUS TRAINING!**

**NO EXPERIENCE NECESSARY**  
**LEARN TELEVISION AT HOME**  
**IN YOUR SPARE TIME!**



Grant Screen TV Receiver

### GET MORE! LEARN MORE! EARN MORE!

I give you ALL the equipment and training you need to prepare for the BETTER PAY jobs in TV. While training, many of my students make \$25.00 a week repairing Radio-TV sets in their spare time... start their own profitable service business.

#### MORE EQUIPMENT!

You build and keep this professional **GIANT SCREEN TV RECEIVER** complete with big picture tube (designed and engineered to take any size up to 21-inch). Also all units illustrated, plus additional equipment! Everything supplied complete with all tubes.



Super-Het Radio Receiver

#### FREE FCC COACHING COURSE!

Prepares you at home for your FCC License, the best jobs in TV and radio require an FCC License. My FCC Coaching Course is given to you at **NO EXTRA COST** after TV Theory and Practice is completed.



CW Telephone Receiver

#### NEW! PRACTICAL TV CAMERAMAN & STUDIO COURSE!

For Men With Previous Radio & TV Training

I train you at home for an exciting big pay job as the man behind the TV camera. Work with TV stars in TV studios or "on location" at remote pick-ups! A special one-week course of practical work on TV studio equipment at Pierce School of Radio & TV, our associate resident school in New York City, is offered upon your graduation.



Combination Voltmeter-Ammeter-Ohmmeter

#### FM-TV TECHNICIAN TRAINING!

My FM-TV Technician Course will save you months of training, if you have previous Armed Forces or civilian radio experience. Complete with kits, **BIG SCREEN TV RECEIVER**, and **FREE FCC Coaching Course**.



Public Address System

#### OPTIONAL: TWO WEEKS TRAINING IN NEW YORK CITY AT NO EXTRA COST

You get two weeks, 50 hours, of intensive Laboratory work on modern electronic equipment at our associated school in New York City—Pierce School of Radio and Television. And I give you all this **AT NO EXTRA COST** whatsoever, after you finish your home study training in the Radio-FM-TV Technician course and FM-TV Technician Course.

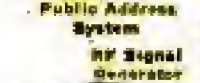

RF Signal Generator



### RADIO-TELEVISION TRAINING ASSOCIATION

52 EAST 19th STREET, NEW YORK 3, N. Y.  
Licensed by the State of New York Approved by the N.E.A.

## VETERANS!

MY SCHOOLS FULLY APPROVED TO TRAIN VETERANS UNDER NEW G.I. BILL! If discharged after June 27, 1950—**CHECK COUPON BELOW!** Also approved for RESIDENT TRAINING in New York City... qualifies you for full subsistence allowance up to \$160 per month. Write for details.



### MAIL COUPON TODAY!

MY 4 FREE AIDS SHOW YOU HOW AND WHERE TO GET A BETTER PAY JOB IN TELEVISION!

See for yourself how my simple, practical methods make success easy.



### NO SALESMAN WILL CALL!

Mr. Leonard C. Lane, President  
RADIO-TELEVISION TRAINING ASSOCIATION  
52 E. 19th Street, New York 3, N. Y. Dept. M-218

Dear Mr. Lane: Mail me your NEW FREE BOOK, FREE SAMPLE LESSON, and FREE aids that will show me how I can make BIG MONEY IN TELEVISION. I understand I am under no obligation and no salesman will call.

(PLEASE PRINT PLAINLY)

NAME \_\_\_\_\_ AGE \_\_\_\_\_

ADDRESS \_\_\_\_\_

CITY \_\_\_\_\_ ZONE \_\_\_\_\_ STATE \_\_\_\_\_

I AM INTERESTED IN:

- Radio-FM-TV Technician Course **VETERANS!** Check here
- FM-TV Technician Course for Training under NEW
- TV Cameraman & Studio Course G.I. Bill



YOU  
can  
acquire

## LAW NIGHTS AT HOME! L. L. B. DEGREE

LaSalle's famous Law Library—used as reference in many Law libraries and Law offices—has enabled thousands to master Law surprisingly fast, in spare hours at home, for business and professional advancement.

These 14 remarkable volumes, compiled by leading professors and lawyers, cover the whole basic field of Law in condensed, orderly, simplified manner.

You advance rapidly with this great library, plus special lectures furnished. We guide you step-by-step with personalized Problem Method of instruction . . . you learn by doing—handling legal problems—not by memorizing rules.

Send for two FREE 45-page booklets, "Law Training for Leadership," and "Evidence," answering questions about Law and its value to you, and telling how LaSalle Law graduates are winning rapid advancement in business and public life. Mail coupon below. No obligation.

### LA SALLE EXTENSION UNIVERSITY A Correspondence Institution

417 S. Dearborn St. Dept. 264L Chicago 5, Ill.

Send me your two FREE booklets described above, without obligation.

Name.....Age.....

Street.....

City, Zone & State.....

## ENGINEERING DEGREE IN 27 MONTHS

### Big Demand for Graduates

**Aeronautical, Chemical, Civil, Electrical, Mechanical and Radio Engineering (inc. TV and Electronics)**

Hundreds of young men are earning B. S. ENGINEERING DEGREES annually in this recognized institution — year around operation. New terms start quarterly. Many students earn a major part of their college expenses in this large industrial center.

Low tuition. Competent instruction. Thorough, intense, practical program. Modern, well-equipped laboratories including new physics laboratory and modern wind tunnel. Individualized instruction emphasized.

Government approved for G.I.'s. Engineering preparatory courses. Students from 48 states and 21 foreign countries. Enter March, June, September, December. Send coupon for free catalog and full information. Enroll now.

SEND COUPON TODAY

## INDIANA TECHNICAL COLLEGE

524 E. Washington Boulevard  
Fort Wayne 2, Indiana

Please send me free information on B.S. Engineering Degree in 27 months as checked.

Aeronautical,  Chemical,  Civil,  Electrical,  
 Mechanical,  Radio-Television

Name.....

Address.....

## INVENTORS

IF YOU WISH TO PROTECT YOUR INVENTION, You should take steps to protect it by a U. S. Patent. Write me for "INVENTION RECORD" form

### CARL MILLER

REGISTERED PATENT ATTORNEY

WOOLWORTH BLDG., 35th FLOOR, 24A  
NEW YORK CITY



## PATENTS

### C. A. SNOW & CO.

REGISTERED PATENT ATTORNEYS  
WRITE FOR INFORMATION TO  
433 SNOW BUILDING, WASHINGTON 1, D. C.

## INVENTORS

Whether an invention is patentable can be substantially determined by a search of the U. S. Patent records. Without obligation, write for information explaining the steps you should take to secure a patent.

### JOHN N. RANDOLPH

Registered Patent Attorney

201 Columbian Building, Washington 1, D. C.

## HELPFUL BOOKS

Send post card asking for FREE catalog

Popular Mechanics Press, 200 E. Ontario, Dept. 801, Chicago 11

## INVENTORS

Send for  
PATENT INFORMATION REGISTERED PATENT  
Book and ATTORNEY

INVENTOR'S RECORD Patent Attorney & Advisor  
without obligation U. S. NAVY DEPT. 1930-1947

GUSTAVE MILLER ASSOCIATE EXAMINER  
24-PM WARNER BUILDING U.S. PAT. OFF. 1932-1939  
WASHINGTON 4, D.C. PATENT LAWYER

## INVENTIONS For Sale

Our clients have excellent inventions in many fields to be manufactured and marketed on a cash, royalty or license basis. Full description of clients' inventions will be sent if you state your field of interest. INVENTIONS: We also want inventions of every type. Write for details.

### GLOBAL MARKETING SERVICE

1404 Mitchell Street Dept. MS Oakland 1, Calif.

## INVENTORS

I shall be pleased to furnish you, upon request, with full information relative to patent procedure—without any obligation on your part.

### PATRICK D. BEAVERS

Registered Patent Attorney

934 Columbian Building Washington 1, D. C.

**Tired of Being Ashamed of Your Build?**

# LET ME GIVE YOU A NEW HE-MAN BODY!

*Charles Atlas*

Awarded the title of "The World's Most Perfectly Developed Man" in an international contest.

**My Secret Method Has Worked for Thousands No Matter How Skinny or Flabby They Were — Now, Why Not Let It Work For You?**

**HERE'S WHAT I'LL PROVE  
15 MINUTES A DAY CAN DO FOR YOU**

I don't care how old or young you are, or how ashamed of your present physical condition you may be. If you can simply raise your arm and flex it I can add **BOLID MUSCLE** to your biceps—yes, on each arm—in double-quick time! Only 15 minutes a day—right in your own home—is all the time I ask of you! And there's no cost if I fail.

I can broaden your shoulders, strengthen your back, develop your whole muscular system **INSIDE** and **OUTSIDE**! I can add inches to your chest, give you a vise-like grip, make those legs of yours lithe and powerful. I can shoot new strength into your old backbone, exercise those inner organs, help you cram your body so full of pep, vigor and red-blooded vitality that you won't feel there's even "standing room" left for weakness and that lazy feeling! Before I get through with you I'll have your whole frame "measured" to a nice, new beautiful suit of muscles!

**WHAT'S MY SECRET?**

"**DYNAMIC TENSION!**" That's the ticket! The identical natural method that I myself developed to change my body from the scrawny skinny chested weakling I was at it to my present superman physique! Thousands of other fellows are becoming marvelous physical specimens—my way. I give you no gadgets or contraptions to fool with. When

you have learned to develop your strength through "Dynamic Tension" you can laugh at artificial muscle-makers. You simply utilize

the **DORMANT** muscle-power in your own God-given body—watch it increase and multiply double-quick into real solid **LIVE MUSCLE**.

**FREE** Illustrated 32-page Book. Just Mail the Coupon.

SEND NOW for my famous book, "Everlasting Health and Strength." Packed with actual photographs. Page by page, it shows what "Dynamic Tension" can do for YOU.

This book is a real prize for any fellow who wants a better build. Yet I'll send you a copy absolutely FREE. Rush coupon to me immediately. CHARLES ATLAS, Dept. 8B, 115 East 23rd St., New York 10, N.Y.



"I gained 31 lbs. and 4 1/4 inches on my chest, 3 inches on my arms. I am never constipated."  
—Henry Neven, Canada

"I gained 34 lbs. and increased my chest 5 inches!"  
—Stanley Lynn, Calif.

"What a difference! Have put 31 1/2 inches on my chest (normal) and 2 1/2 inches expanded!"  
—F. S., New York

"Gained 29 pounds. When I started your course I weighed only 141. Now I weigh 170."  
—T. K., New York



**ARE YOU**  
Skinny, weak, and run down?  
Always tired?  
Nervous?  
Lacking in confidence?  
Constipated?  
Suffering from bad breath?  
Fat and flabby?  
Do you want to lose or gain weight?  
**WHAT TO DO ABOUT IT** is told in my **FREE BOOK.**

  
**SILVER CUP GIVEN AWAY**  
This handsome cup, over a foot high, will be given to the pupil who makes the greatest physical improvement in the next 8 months.

**CHARLES ATLAS, Dept. 8B,  
115 East 23rd St., New York 10, N. Y.**

Send me—absolutely **FREE**—a copy of your famous book, "Everlasting Health and Strength"—32 pages, crammed with photographs, answers to vital health questions, and valuable advice. I understand this book is mine to keep and sending for it does not obligate me in any way.

Name.....Age.....  
(Please print or write plainly)

Address.....

City.....State.....

# FOR YOUR TECHNICAL AND VOCATIONAL TRAINING

Come to the  
**UNIVERSITY OF HOUSTON**

One of America's large and most modern universities. Select from these fascinating fields:  aeronautics  air conditioning & refrigeration  auto body and paint  auto mechanics  auto upholstery & trim  diesel  drafting  electricity  electronics  machine shop  photography  radio  stationary engineering  television  welding  woodworking  furniture upholstery. **PREPARE FOR YOUR FUTURE NOW** . . . with very latest methods and equipment, at modern U. of Houston College of Technology. Entrance: high school diploma, or over 18 and ability to profit from instruction. Beautiful campus—250 wooded acres in Houston, Texas—city of tomorrow. Full college activities, sports, social life. Day or night, short or longer courses. Co-op work-study programs . . . earn part of tuition and expenses with part-time job in your own career field, while you learn. Personal vocational counselling. Diploma on completion and all credits apply towards Bachelor of Applied Science Degree. Job placement assistance. Feb., June, Sept. semesters. Mail ad now for Free fully-illustrated brochure. No obligation. Mark X before choice of subject. Do it today!

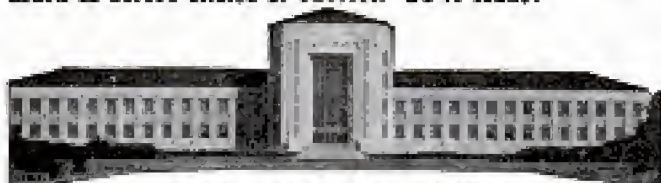

ADMINISTRATION BUILDING

**University of Houston, College of Technology**  
Dept. 124 — HOUSTON 4, TEXAS

## DIESEL MECHANICS NEEDED

### BIG PAY—GOOD FUTURE

Virtually all heavy power equipment is rapidly going DIESEL, creating big paying, steady jobs—through good times or bad—for properly trained men.

Back during the DEPRESSION . . . there was a big demand for Bailey Trained Diesel mechanics.

We can QUICKLY TRAIN YOU to enter this big pay field . . . no previous experience or special education necessary!

With our method of training you don't spend years pouring over books, figures, charts or graphs—you learn by repairing and operating big Diesel engines, under the guidance of experienced and friendly instructors.

This method of training gives you the experience and confidence that enables you to move right into the BIG PAY JOBS without spending years-as-a mechanic's helper. We help you find part-time jobs while in school—full-time jobs after graduation. Mail coupon for complete information.

### BAILEY Technical SCHOOLS

Veteran Approved

1626 S. Grand St. Louis 4, Mo.

NAME . . . . . AGE . . . . .  
STREET . . . . .  
TOWN . . . . . ZONE . . . . . STATE . . . . .

## "How to Become a Mail Order Millionaire"



Read the inside facts about hundreds of "little fellows" who are running Mail Order businesses from their homes—many making \$20,000 and more every year! Learn how small investments (\$16.80 in one case!) have mushroomed into profits of thousands. This incredible

**SENT  
FREE!**

RUSH NAME ON  
POSTCARD TODAY

reprint from *Mechanix Illustrated* will be sent absolutely free, along with details showing how you can quickly master the secrets of getting orders and money in your daily mail, in a business that's all yours. Rush name today. A postcard will do.

**The L. W. SURVEY 805 Larrabee St., Dept. 12,  
Los Angeles 46, California**

## FOR BIG MEN ONLY!



SIZES 10 to 16 WIDTHS AAA to EEE

We SPECIALIZE in large sizes only—sizes 10 to 16; widths AAA to EEE. Lounge, Dress, Oxford, Hosiery, Custom Crepe, High and Low Work Shoes, Slipper, Rubber, Overboard, Sox. Enjoy the finest fit, comfort, style at amazingly low cost. Send by mail only. Write for FREE size Book TODAY!

SEND  
FOR  
FREE  
CATALOG

**KING-SIZE, Inc., 406, Brockton, Mass.**

## REAL ESTATE BE A BROKER

PAYS BIG! SEND FOR FREE, BIG, ILLUSTRATED CATALOG NOW! Graduates report making substantial incomes. Start and run your own business quickly. Men, women of all ages. Learn easily. Course covers Sales, Property Management, Appraising, Loans, Mortgages and related subjects. STUDY AT HOME or in classrooms in leading cities. Diploma awarded. Write TODAY for free book! No obligation.

FREE  
BOOK  
TELLS  
NOW

Approved for World War II and Korean Veterans  
**WEAVER SCHOOL OF REAL ESTATE (Est. 1930)**  
Suite 300 Law Bldg. Dept. PM Kansas City, Mo.

### 500 TRICKS

## MAGIC TRICKS

### IT'S FUN TO DO MAGIC

Be popular! Amuse—mystify—entertain! For 30 years Douglas has satisfied customers all over the world. Now, you can enjoy this fascinating hobby. Only 10c brings our Catalog 500 Tricks, containing brand new tricks for pocket, parlor, stage. Join in the fun—send 10c today!

Douglas Magieland, Dept. A, Dallas, Texas

## POWER MOWERS & KITS

FREE  
PLANS

LOW FACTORY  
PRICES DIRECT  
TO YOU



3 & 4 Wheel Model

Build your own quality mowers with our LOW COST KITS. Parts, Engines. Free Plans guide you. 3 and 4 Wheel Kits, complete. Parts predrilled finished, ready to use. Write TODAY for Free List, Low Prices, Parts List and Guarantee.



4 Wheel Direct Drive

3-WHEEL KIT NO. T-800



America's Finest Power Mowers completely assembled in 3 and 4 wheel models. Belt or direct drive. 18" and 20" sizes. Nationally known make engine. Latest improved features, sturdy construction and money back guarantee fully described in color folder. Write today!

▼ **TRIANGLE MANUFACTURING CO., Box M-27, Fort Scott, Kansas**





# Fix ANY Car!

**FAST! EASY! RIGHT!**  
 ANY make - ANY model - ANY part

**Chilton's  
 AUTO-  
 MOBILE  
 REPAIR  
 MANUAL**

**New edition**  
 Covers over 1100 models by these mfrs. between 1940 and 1953

- Buick
- Cadillac
- Chevrolet
- Chrysler
- DeSoto
- Dodge
- Ford
- Fraser
- Honey I.
- Hudson
- Kaiser
- Lincoln
- Mercury
- Nash
- Oldsmobile
- Packard
- Plymouth
- Pontiac
- Studebaker
- Willys

Handle any auto repair job easier, faster than you may have dreamed! Fix any part of any car from old 1940 models to the shiniest, most complicated of the new ones!

Just look it up! The giant Chilton ALL CARS service manual shows just what to do . . . explains exactly how to do it.

◀ **The Book that Really S-H-O-W-S You How!**

Now beginners can easily handle jobs they may not have thought possible for them. Experienced mechanics can save hours, help boost their pay checks to bigger figures.

You work fast, and r-i-p-h-t! From tune-ups to complete

overhauls: from carburetors, brakes, ignition systems, motors for power steering to the newest automatic transmissions, the Chilton ALL CARS Manual gets right down to "brass tacks" in making every step easy to understand, easy to do.

◀ **A "GOLD MINE" OF HOW-TO-DO-IT WORDS AND PICTURES**

Right at your fingertips, you have amazingly complete service data on every car made from 1940 through June 1953.

Covers over 1100 models of 20 makes. Includes 38,000 specifications and 350 Quick Check Data Tables. Over 1000 big, clear pictures and dia-

grams explain things almost at a glance. Service short cuts help you handle jobs lots easier.

Contains 752 pages, each one almost TWICE as big as this magazine page. Manual is 1 1/2" thick, bound in heavy covers for use right on the job.

◀ **By the World's Largest Automotive Publishers! . . . Used by the U. S. Armed Forces**

Throughout, you get how-to-do-it data on specific jobs — NOT a lot of general theory.

Everything is clearly indexed. You can find just what you want in a jiffy.

Remember! This big 4 1/2 lb. manual is prepared by the 10-man staff of MOTOR AGE and AUTOMOTIVE INDUSTRIES magazines, the Flat Rate Book and others that make Chilton the world's largest automotive publishers. It is accurate and up to date. Chilton editors work hand in hand with car makers—have full access to service data—and they know how to explain things as simply as A-B-C.

Send no money! Just mail the coupon today. Practice from the Chilton ALL CARS service manual for 10 full days. If not more than satisfied, return it postpaid and don't owe us a cent! Send coupon to: The Chilton Co., 56th & Chestnut Sts., Philadelphia 39, Pa.

Read what to do . . .  
**SEE** exactly how to do it!  
 Over 1500 big, clear pictures, etc. help you breeze through jobs "slick as a whistle".

**Send No Money**  
 Practice 10 days FREE!

**These men know!**



**FAST!** "Thanks to the Chilton Manual, I did a job in an hour another mechanic had worked on all day."  
 Gene Arnold, Iowa



**EASY!** "The how-to-do-it pictures are worth the entire price of the manual!"  
 Melvin Wade, Pa.



**CLEAR!** "A nice thing about the Chilton Manual is that you don't have to have a lot of previous training. It makes every job easy to understand."  
 Otto Marzettey, Ill.



**NOW! Low Cost Special Manuals on the 3 most popular makes!**

**Ford**  
**Chevrolet**  
**Plymouth**  
 (incl. Dodge & DeSoto)

Now you can get individual manuals on these three popular makes AT A BIG CASH SAVING! Each contains complete service data on EVERY MODEL of that make from 1940 through June 1953. Each has over 150 pages, hundreds of special photos, charts, diagrams, etc. Only \$2.75 each. Check the one you want in coupon. 10-DAY MONEY-BACK GUARANTEE protects you fully!

**THE CHILTON CO., Dept. PM-24**  
 56th & Chestnut Sts., Philadelphia 39, Pa.

Please send the following manual (check the ones you want):

Send the big CHILTON "ALL CARS" REPAIR MANUAL (price \$3.95) for 10-day FREE EXAMINATION. If I like it, I will promptly remit \$1.95 (plus 35c postage); then send \$2 monthly for 2 months. Otherwise, I will return manual postpaid in 10 days and owe nothing.

Check here }  Chilton "CHEVROLET" Manual, price \$2.75 for special manuals }  Chilton "FORD" Manual, price \$2.75  
 Chilton "PLYMOUTH-DOBBS-DESO" \$2.75

**NOTE:** Above special manuals sent for  cash with order (we pay postage). Or,  we ship C.O.D. and you pay postman for manual plus post office charges. Specify which method. Any manual returnable postpaid in 10 days and we guarantee to refund your \$2.75.

**OUTSIDE U.S.A.—Cash only. "ALL CARS" Manual, \$6.05. Special Manuals, \$3.00 each. Same 10-day return privilege with money refunded.**

Name \_\_\_\_\_  
 Address \_\_\_\_\_  
 City, Zone, State \_\_\_\_\_

# Learn to MOUNT Birds and Animals



**To All Men & Boys!**  
Here is **FUN** and **PROFIT!**

## Send Coupon for Free Book

Tells all about Taxidermy, and how you can best at home to mount (Deer-like Birds, Animals, Game-Heads, Fish). Shows you valuable trophies. Decorate your home and den. Learn genuine Chinese Tanning for harness and sole leather breeches and fine furs. Mount Common specimens, squirrels, rabbits, cats, even frogs. Use marvelous craft-work groups, both useful, humorous, Wild game not necessary. Murreson hobby. Fascinating.

**BIG PROFITS** Turn your spare-time to cash. Have a sideline profitable business. Mount game trophies for sportmen; sell your own trophies; save money and Make Money with expert tanning. Learn by mail from old reliable school with 400,000 graduates. **Investigate Now.** Send request of letter or book and Right Now for this marvelous **FREE BOOK.** There is no cost or obligation. Please state your AGE.

## FREE BOOK

Northwestern School of Taxidermy,  
2502 Elwood Bldg., Omaha, Neb.

Gentlemen:—Please send me your FREE 48-page booklet explaining Taxidermy. Please print plainly and state age. Use postal card if more convenient.

Name \_\_\_\_\_ Age \_\_\_\_\_

Address \_\_\_\_\_



## SAY YOU SAW IT IN POPULAR MECHANICS



## How YOU can make BIG MONEY operating this franchised Roadside Stand

You can start a business of your own with an amazingly small investment . . . and make thousands of dollars like others who follow our *proved* methods of stand building and operating. Our free folder gives you the facts—tells you how hundreds of men like you have built successful, profitable businesses of their own—tells you just how to proceed. Send for your free copy.

**GO IN BUSINESS FOR YOURSELF!**  
**FREE FOLDER TELLS HOW**



RICHARDSON Corp.  
Dept. PM-2, Rochester 3, N. Y.

Please send me FREE folder on the franchised RICHARDSON refreshment stand.

Name.....

Address.....

Place.....

## EARN \$25 TO \$75 A WEEK IN SPARE TIME ... No Selling To Do!



### With Guaranteed JETMATIC Venetian Blind Laundry

No risk. Because you start your own business part time in your basement or garage. In a short time, when your profits exceed your job salary, you will make it your FULL-TIME business. As hundreds of others have done. Tremendous unfulfilled demand from homes, offices, factories, for this new-kind service. JETMATIC, made by world's logical manufacturer of professional Venetian blind buildings, guarantees perfect results without taking blinds apart, without handling. WRITE TODAY for complete details and experiences of hundreds of men of all ages who are making more money with the JETMATIC.

No Experience Necessary

L. C. ROBINSON MANUFACTURING CO.  
522 North Rural St. DEPT. MD Indianapolis 1, Ind.

## BUILD LUGGAGE AT HOME WE SELL YOUR PRODUCTS!

ONLY NEW HOME MONEY-MAKING PLAN IN YEARS!

Make Luggage and cases for traveling, photographers, musicians, salesmen, electronics, tools, portables, 1000 other items. Also repair Luggage. No special equipment needed. BIG Profits. We supply complete instructions—everything. Write for free details and Business Plan. ABARSI CASECRAFT, Dept. M5, 805 W. Sunset Blvd., Los Angeles 12, Calif.

## IMPROVE YOUR PENMANSHIP

*Write Like This*

YOUR penmanship can be improved in 3 hours or corrected to your satisfaction in 10 hours' practice with my **DEFINITE HAND CONTROLS**. New way!

WRITE OZMENT BOX 665  
24-N. ST. LOUIS, MISSOURI

Complete  
OUTLINE  
FREE!

## MECHANICAL DENTISTRY

To make Crowns, Plates, Bridge-work, etc., for Dentists. Easy practical way to learn mechanical dentistry at home in spare time. FULL EQUIPMENT OF TOOLS AND MATERIALS INCLUDED WITH COURSE. Low tuition. Easy terms. Write for FREE BOOK about this money making profession that is not affected by machine age.

McGARRIE SCHOOL OF MECHANICAL DENTISTRY  
207 N. Broad St., Dept. 26, Philadelphia 7, Pa.



## SEND FOR THIS FREE!

Make money. Know how to break and train horses. Write today for this book FREE, together with special offer of a course in Animal Breeding. If you are interested in Galting and Riding the saddle horse, check here ( ) Do it today—now.

BEERY SCHOOL OF HORSEMANSHIP  
Dept. 1102 Pleasant Hill, Ohio

## SUCCESS • BIG PAY in Aviation

## MASTER A & E MECHANICS

urgently needed

Maximum training in minimum time! Thorough, practical instruction backed by more than 25 years of aviation technical experience. Training authorized under G.I. Bill.

Write today!  
Illustrated Catalog  
Registrar, Dept. 99,  
Miami 30, Florida



TRAIN IN MIAMI -- AIR CAPITAL OF THE WORLD

# Build a Better Garage for One Half the Cost!

Get New Popular Mechanics Book Before You Build, Buy or Plan Any Garage

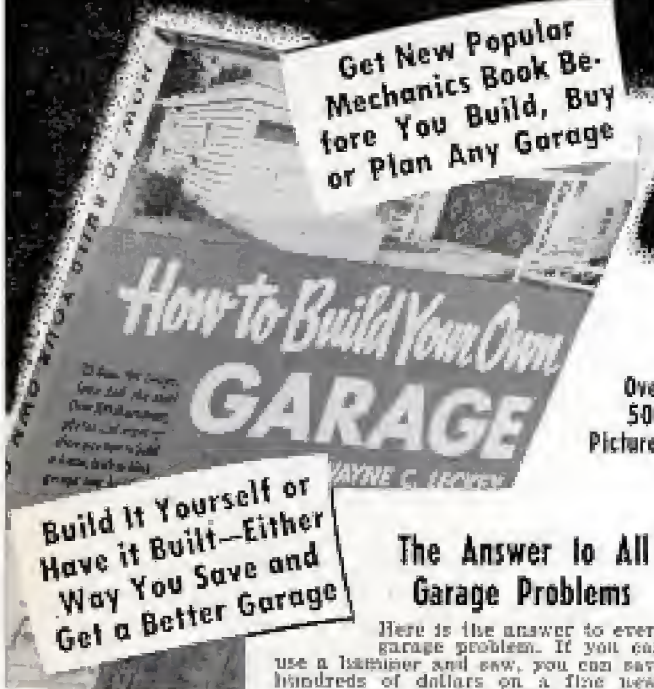

Over 500 Pictures

Build It Yourself or Have it Built—Either Way You Save and Get a Better Garage

## The Answer to All Garage Problems

Here is the answer to every garage problem. If you can use a hammer and saw, you can save hundreds of dollars on a fine new, modern garage. Get "How to Build Your Own Garage," Popular Mechanics' simplified How-to-Do-it book for the amateur builder and follow the pictures and instructions. If you prefer to have your garage built by others, get this book first for it can solve any garage problem you may have.

Prepared especially for the inexperienced builder by Wayne C. Leckey, associate drafts editor of Popular Mechanics, with the assistance of many builders, manufacturers and associations in the building, lumber and hardware fields, it TELLS HOW in simplified, step-by-step instructions—SHOWS HOW with hundreds of plans, diagrams and actual photographs.

### Money Back Guarantee

Mail the coupon for "How to Build Your Own Garage" today. Use the book for 7 days and return it for full refund if it does not please you. You can't lose under the P. M. guarantee of satisfaction or your money back.

Car Ports, Garages—Brick, Block, Frame—They're All Here!

Also valuable information on attractive garage doors; how to dress up a garage; space for storage, workshop, recreation, automatic door operators, planning and making your own driveway—plus pictures and instruction for every construction detail if you want to build your garage yourself.

### 25 Designs to Choose From

Every type—every style—every size. All shown in actual photographs to help you make your own choice. Actual building plans available for many of the garages shown.



Two-car frame garage amateur can build and getting garage under cover with large sheets of plywood. Both illustrations from the book.

## Use This Money Back Coupon

POPULAR MECHANICS PRESS, Dept. GB-2  
200 E. Ontario St., Chicago 11, Ill.

Send at once, "How to Build Your Own Garage" under your 7 day trial, money-back guarantee.  Remittance for \$3.50 enclosed. Send postpaid.  Send C.O.D. (U.S.A. only). I will pay postman \$3.50 plus charges.

Name \_\_\_\_\_

Address \_\_\_\_\_

City \_\_\_\_\_ Zone \_\_\_\_\_ State \_\_\_\_\_

# The WONDERS of LIQUID PLASTICS

MANUFACTURE WITHOUT TOOLS OR MACHINERY! WE PAY YOU \$5.00 AN HOUR!

No previous experience or special ability required! NO TOOLS OR MACHINERY required! . . . The entire process is about as easy as pouring water out of a glass! The WONDERS OF LIQUID PLASTICS make all this possible! Many of the products made with our liquid plastics are so beautiful and attractive that we have created an unusual demand for this type of material! That's why we will pay you \$5.00 an hour (materials extra) to make the items shown here and in our catalog for us!

### UNLIMITED POSSIBILITIES

Work with LIQUID IVORY, LIQUID GLASS, LIQUID MARBLE, LIQUID EMBROIDERY, LIQUID PORCELAIN, LIQUID WOOD, LIQUID MARBLE STONE and many other LIQUID PLASTICS and in a matter of minutes turn them into an endless and valuable procession of beautiful imbedded jewelry, novelties, ornaments, statuettes, bookends, lamp, pens, lighters, ashtrays, keychains, figurines, cups, SOUVENIRS, art and gift products, fishing lures, BOATS, GADGETS, CALIBER, exquisite GEMMS! Make gears, tools, dice, fuma, handles, dials, knobs, MACHINE PARTS, models of inventions, plated pipes . . . the list is endless! The only LIMITATION is your IMAGINATION! Liquid Plastics are the blessing of every creative and ambitious person . . . with these materials ANYONE can create and manufacture by the THOUSANDS and at a tiny fraction of what it would cost by any other method! Just send 25c and we will send you our book, "HOW TO MANUFACTURE WITHOUT TOOLS OR MACHINERY," included with our big 64 page catalog describing all the materials mentioned above; also details of our \$5.00-an-hour offer! Do it today . . . we want you to share in these wonderful opportunities as soon as possible!



PLASTICAST CO., (Dept. C)  
P.O. Box 6737 (Write to P.O. Box 287 Chicago 90, Ill. either address) Palo Alto, Calif.



## PLASTIC LAMINATING

This remarkable Plastic Laminating Machine will earn \$18.00 an hour right in your kitchen! Big profits Laminating Business. Social Security, Identification, Credit CARDS of all kinds, photos, notices, clippings, etc. Price complete illustrated \$38.00 plus postage. Others higher. Literature free. PLASTICAST CO. (Address in ad above)

Say You Saw It in Popular Mechanics

# NEW "PAINT PEN"

PAINT STRIPING TOOL Works like a Fountain Pen Stripes with Paint instead of Ink!

This amazing new "PAINT PEN" is a Paint Stripping Tool that makes it easy to do expert striping on fountains, bikes, metal cans, auto, wire, tops, toolboxes, wall board, etc. Makes plain, painted walls look like tile. Paint straight, curved, circular or evenly spaced parallel lines the same way a professional painter does. Simply fill Tubular Glass Paint Reservoir with any color paint and what tip leads paint event. Tip interchangeable—has 1/2" apart for easy cleaning. Tool complete with tip for 1-16 inch stripes only \$1.00 postpaid, other complete tools with 1/8", 1/32", 3/64", 1/16", 1/8", 1/4", 1/2", 3/4", 1", 1 1/2", 2", 3", 4", 6", 8", 10", 12" tips, \$1.00. Extra tips, 75c ea. Complete B.T. with 1/16" tip, \$6.00. Also 1-4 in. tip only \$1.00. L.O.O.P.'s postage extra. Here's the handiest tool in your whole painter's kit. Get yours today.



Paint STRAIGHT, CURVED OR PARALLEL LINES

## Home Craftsmen

Just the tool you've been waiting for! New Paint Stripping Tool gives "no-fuss" results every time. Yet simple and easy to use as a fountain pen. Adjustable side access hole straight as an arrow. Just an ear to make curves or free hand designs. Adds new beauty and finished look to everything you paint. Send \$1 now!

DEALERS PAINT STRIPING TOOL. Packed in display cartons of 1 doz. Fast, profitable seller. Write for illustrated circular, discounts

Only \$1.00

WENDELL MFG. CO., Dept. 3-B 4234 LINCOLN AVENUE, CHICAGO 18, ILL.

Send for it today  
**The Most ESSENTIAL BOOK for the Automobile Mechanic Today!**

If you are—or want to be an auto mechanic you must own this book.

**Complete Guide to Maintenance, Service, Test and Overhaul**

# AUTOMATIC TRANSMISSIONS

Over 500 photos and drawings. Comprehensive—Authoritative, written by well known technical expert Ray F. Kuna. Covers all types. Explains use of hydraulic test equipment to save time, trouble by showing what is wrong before taking a transmission apart. Simple step-by-step explanations.

Get ready now for really big pay—be among the first to know **AUTOMATIC TRANSMISSIONS**—become expert on all types. Many say in next few years automatic transmissions will replace all other types. Examine this remarkable book on a **FIVE DAY FREE TRIAL OFFER**—if not entirely satisfied return it and your money will be refunded. **MAIL THE COUPON TODAY.**

Now only \$5.00

**MAIL COUPON TODAY—EXAMINE FOR 5 DAYS**

THE BRUCE PUBLISHING COMPANY  
 1302 Bruce Building • Milwaukee 1, Wisconsin  
 Please send me **AUTOMATIC TRANSMISSIONS, Principles and Maintenance**. If I am not entirely satisfied I shall return the book in 5 days and my money will be refunded.  Send C.O.D.  I enclose \$5.00 (Send cash, save C.O.D. charges)

Name.....

Address.....

City.....Zone.....State.....



Only \$5

# SHORTHAND IN 6 WEEKS

Write 120 words per minute  
 Age no obstacle — Lowest Cost

Famous Speedwriting Shorthand. No symbols, no machines; uses ABC's. Easiest to learn and use. Fast preparation for a better position. Nationally used in leading offices and Civil Service; also by executives, students, etc. 120 words per minute—50% FASTER than Civil Service requirements. Over 200,000 taught by mail. The very low cost will surprise you. Typing available. First Year Schools in over 400 cities in U.S., Canada, Cuba and Hawaii.

WRITE FOR FREE BOOKLET TO:

**Speedwriting**  
 Dept. 1982-4, 55 W. 42 St., N. Y. 36

# BECOME AN EXPERT IN TRAFFIC

Traffic men earn \$4,000 to \$10,000 and up. Thousands of firms need experts on rules, traffic regulations. We train you thoroughly in spare time at home for executive traffic jobs. Personal training under traffic authorities. Placement control and help. Write for free 48-page book "Traffic Management—The Fast Growing Profession."

LASALLE Extension University, 417 So. Dearborn St.  
 A Correspondence Institution Dept. 2647 Chicago 5, Ill.

Want a HOME?



Before you choose, be sure to GET THE FACTS about Schult mobile homes. Write or wire Dept. 3202 SCHULT CORP., ELKHART, IND.

**SCHULT TRAILERS**

# BRASS NAME PLATES or KEY TAGS

YOUR NAME  
 STREET AND NUMBER  
 CITY AND STATE  
 PHONE NUMBER

**40c each**

Half actual size QUANTITY PRICE — SAME STAMPING  
 2 for \$2 — 15 for \$3 — 25 for \$4 — 50 for \$6  
 LARGER QUANTITIES ON REQUEST

TAGCO, P. O. BOX 203 X, PLEASANT VALLEY, N. Y.

# INVENTOR BARES SECRETS

Successful engineer-inventor strips mystery from invention and science in outstanding document. 25,000 hard-hitting words prove that a college degree is not necessary to make a fortune in these fields. Send only \$2.00 or write for free added information PANORAMIC RESEARCH • 4421 N. 14th St. • Phoenix 43, Arizona

SEND FOR THIS DOCUMENT TODAY!

# AVIATION Pays You More With a Schooling at PARKS

## NOW! A&E MECHANIC LICENSE COURSE

45-week course, all phases aircraft & engines. Enrollment Dates: Apr. 15-16, 1954

**FLIGHT COURSES**—Private, Commercial, Instrument, Instructor, Multi-Engine.

**DEGREE COURSES**—B.S. degree in 3 yrs. from Saint Louis University — Aero. Engineering, Maint. Engineering, Aero. Administration.

All Parks Schooling Approved for Veterans Write Today.

**PARKS COLLEGE** ARNOLD HALL EAST ST. LOUIS, ILL.

# GREER SHOP TRAINING

Leader in Practical Training for 50 Years

Gain success by learning a trade offering security and high pay—go into business for yourself.

Get the "Know-how" of Greer

You learn in our new, large, modern shops by working with latest tools and equipment of the trade — tear down, inspect, repair and rebuild... under supervision of experts. Greer founded 1902. Over 21,000 successful grads. Part time, full time, day and evening. E-Z terms. Mail coupon today.

CLIP COUPON... MAIL TODAY  
 Greer Shop Training—2230 South Michigan Chicago 16, Illinois Desk 213

Please send information about trade checked:  
 In our Chicago Shops:  Auto Mechanics  
 Body, Fender Repair  Diesel Mechanics  
 Welding—Arc, gas  Tool & Die  
 Refrigeration & Air-conditioning  
 Machinist  Piano tuning

APPROVED FOR CIVILIANS  and G.I.'s   
 (check which)  
 ATTENTION: HIGH SCHOOL GRADUATES.  
 Write for information on 3 year DIESEL-AUTOMOTIVE ENGINEERING COURSE.

Name.....

Address.....

City.....

State.....

Age.....



MACHINIST



WELDING GASARC



BODY REPAIR



DIESEL MECHANICS



AUTO MECHANICS



REFRIGERATION



PIANO TUNING

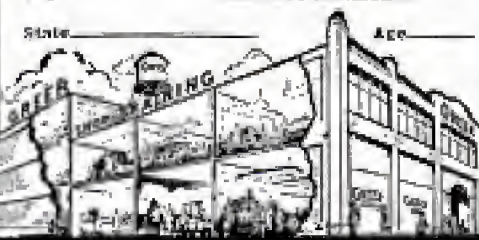



**FIND OUT FREE—HAVE YOU GOT WHAT IT TAKES...**

**to be a FINGER PRINT EXPERT or TRAINED INVESTIGATOR?**

Send for free IAS Qualification Questionnaire. If in our opinion your answers indicate that you "have what it takes," then you will receive absolutely free the famous "Blue Book of Crime" . . . plus full details on how to train at home in Crime Detection and Finger Printing! IAS graduates are key men in over 600 Police Bureaus. See if YOU can train for this exciting, steady "good pay" work! No obligation. No salesman will call. Write today, stating age.

**INSTITUTE OF APPLIED SCIENCE**  
(A Correspondence School Since 1916)  
1920 Sunnyside Ave., Dept. 1352 Chicago 40, Ill.

**WRITE TODAY**

**Learn CARTOONING**

at home in spare time . . . the quick easy London Picture Chart way. Teaches how to originate—today's big need. Scores of successes. Send 10c for Picture Chart (in test ability) and full details. Please state age.

London School of Cartooning, 5402 CT5 Bldg., Cleveland 14, O.



**Say You Saw It in Popular Mechanics**

**LAW** Men and women **STUDY AT HOME** for Business Success and **LARGER PERSONAL EARNINGS**, 44 years expert instruction—over 114,000 students enrolled. LL.B. Degree awarded. All text material furnished. Easy payment plan. Send for **FREE BOOK**—"Law and Executive Guidance"—**NOW!**  
**AMERICAN EXTENSION SCHOOL OF LAW**  
Dept. PM-71, 644 N. Michigan Ave., Chicago 11, Illinois



**FREE 100 STAMPS**  
ALL VALUABLE—ALL DIFFERENT  
Plus This Famous  
**RUSSIAN BEAR STAMP!**

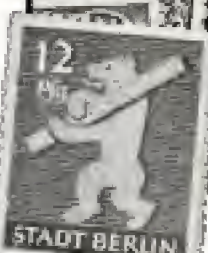

**Guaranteed Catalog Value At Least \$2.00**

WHAT A GIFT! 100 stamps from all over the world . . . all different . . . all valuable! Total Standard Catalog Price guaranteed to be AT LEAST \$2! These stamps have NOT been sorted, so there's no telling what valuable stamps you'll find among them. ALL YOURS FREE—PLUS the famous BERLIN BEAR STAMP, issued by Russians as propaganda to show Russian Bear rebuilding Berlin. We'll also include a FREE copy of our "How to Collect Stamps," plus other interesting offers for your inspection. But hurry! Offer may have to be withdrawn soon. Rush coupon with 10c to help cover postage and handling to: **LITTLETON STAMP CO., Dept. PM-2, Littleton, N. H.**

**LITTLETON STAMP CO., Dept. PM-2, Littleton, N.H.**  
Send **FREE—100 DIFFERENT STAMPS** from all over the world, PLUS Russian Bear Stamp, and exciting, "How to Collect Stamps." I enclose 10c to help cover actual postage and handling costs.  
Name: \_\_\_\_\_ (Please PRINT)  
Address: \_\_\_\_\_  
City: \_\_\_\_\_ State: \_\_\_\_\_

**Do You Earn Less Than \$100 a Week?**

Here's an easy spare-time way to make the extra money you need to live well!

JUST SHOW FOLKS IN YOUR AREA THIS  
Amazing New **"ELECTRIC BRAIN"**

Or Be a FULL-TIME Representative — "the sky's the limit" on Profits!

HERE AT LAST is a miraculous new "electric brain" that makes ANY electrical device, appliance, or lighting system **AUTOMATIC!** Day after day it turns current OFF or ON automatically, for ANY desired length of time, at ANY desired hour of day or night—without re-setting!  
It's like having a quiet, efficient SERVANT who never forgets to have toast and coffee waiting in the morning . . . or to turn on and off the attic fan or dehumidifier . . . to turn off the electric toaster when the toast is done . . . to defrost the refrigerator daily . . . to turn off the sun lamp before sunburn threatens . . . to turn off store window lights and electric signs late at night.  
**Show Your Enthusiasm—Make Big Money**  
Wouldn't it be EASY to share your enthusiasm for this revolutionary new "PRESTO-MATIC ELECTRIC TIMER" with others? Then why be satisfied any longer with "just getting by" on your pres-

ent income? Turn your spare time into CASH—by accepting orders from your neighbors for this new electronic miracle. No investment required—just collect and keep \$3.50 every time you write an order—customer pays balance C.O.D. (Or make up to \$8.50 per unit by buying at our extra-low wholesale prices and re-selling to customers and dealers.)  
No "hunting" for prospects—every home can use two or three units, every commercial establishment at least one. Sell for only \$11.50. Saves time, appliances, electricity—pays for itself again and again. Will handle up to 1500 watt load. **GUARANTEED FOR 1 YEAR** by makers of famous Presto Fire Extinguishers.  
**FREE—Everything You Need to Start!**  
Mail coupon for FREE bulletin showing dozens of uses, FREE sales kit, FREE details. No obligation. But don't delay. Even four sales a day could be netting you \$12 to \$20 a day **RIGHT NOW**. So hurry! Mail coupon at once to: **MERLITE INDUSTRIES, Dept. PT-32, 114 East 32nd St., New York 16, N. Y.**



- **URNS STORE WINDOW LIGHTS** and signs ON and off at desired times
- **MAKES ANY RADIO** a "musical alarm clock"
- **COOKING APPLIANCES** operate themselves—fix toast and coffee, roast dinner, etc.
- **STARTS OR STOPS ATTIC FAN, dehumidifier, air-conditioner, etc.,** at any desired hour.
- **FOOLS BURGLARS** when family's away—turns on lamp every evening
- **DEFROSTS REFRIGERATOR** quickly, cleanly—no mess!
- **MAKES SLEEPING** under sun lamps safe! Turns off lamp at right time
- **DOZENS OF OTHER USES** described in free bulletin

**MERLITE INDUSTRIES, Dept. PT-32**  
114 East 32nd St., New York 16, N. Y.

Please send me—**FREE**—everything I need to get started making big money showing **PRESTO-MATIC ELECTRIC TIMER** to folks.

**CHECK HERE IF YOU WISH TO ORDER ONE UNIT AS A DEMONSTRATOR** (\$7.50). Send no money—we'll ship C.O.D. (Or save money by enclosing \$7.50 now—then WE pay postage. Money back if not delighted.)

Name: \_\_\_\_\_  
Address: \_\_\_\_\_  
City: \_\_\_\_\_ Zone No. \_\_\_\_\_  
if any? \_\_\_\_\_ State: \_\_\_\_\_

# "HOW I DOUBLED MY INCOME In Less Than A Year, As A CUSTOM UPHOLSTERER"



Alvin Lederkramer, Former Low Salaried  
Auto Mechanic — Now Earning Big Pay

"When I enrolled for UTS training I was an auto mechanic earning a meager salary. While learning I earned good spare-time money. After graduation, I got a job in upholstery with better pay than ever before. Now, less than one year later, I've doubled my income. Soon, I'll get into my own business. The future looks bright, thanks to UTS."

WHAT DO YOU WANT? A Better Job—Your Own Business—Substantial Sparetime Earnings—A Better Future? They're all waiting for you in the Big Opportunity Field of Custom Furniture Upholstery.

AT HOME in spare time, you can do what Alvin Lederkramer and other UTS graduates have done—easily, quickly! Trained upholsterers are scarce. You can earn as you learn to make good money all year 'round at home, in your own shop, or in a well-paid job. The practical N.Y. State-approved UTS course teaches you professional custom furniture upholstery, reupholstery, slip covers, furniture finishing, repairs, PLUS 3 BIG

EXTRAS—window cornice, cushion and drapery making. You get—FREE—4 BIG COUNTRIES of tools, complete frames and all materials you use. You make beautiful upholstered furniture and slip covers—yours to keep or sell! FREE book, "Your New Way to A Successful Career," tells how you prepare at home for this big pay, big opportunity trade. WRITE TODAY! Training in N. Y. School also available, Upholstery Trades School, Dept. CB-305, 721 Broadway, N. Y. 3, N. Y.

YOU MAKE

SLIPPER CHAIR

CLUB CHAIR

OTTOMAN

PLUS SLIP COVERS

Yours to keep or sell

## SEND FOR BIG FREE BOOK

UPHOLSTERY TRADES SCHOOL  
Dept. CB-305, 721 Broadway, New York 3, N.Y.  
Send me FREE book on:

Home Study  Training in N.Y. School

Name \_\_\_\_\_  
Address \_\_\_\_\_  
City \_\_\_\_\_ Zone \_\_\_\_\_ State \_\_\_\_\_  
 Check here if Korean Veteran



# MEN! TRAIN NOW FOR A BIG PAY FUTURE IN DIESEL & SCIENTIFIC MOTOR TUNE-UP



- Diesel Construction
- Diesel Engine Repairman
- Diesel Operator
- Industrial Maintenance
- Auto Engine Rebuilding
- Bus & Truck Maintenance

## Be a Trained Diesel Man

Go places with DIESEL! Farms, factories and power plants, trains, ships, trucks, buses all use DIESEL POWER... all need DIESEL-trained men! You can start your DIESEL training at home, in spare time, with tested, proved U.S. 1 training. Course includes practical work on Diesel engines under skilled instructors. You learn the operation, maintenance, servicing of all types of Diesel engines, PLUS Scientific Motor Tune-up.

**ACT NOW!** If you have mechanical ability, you'll like Diesel! High School diploma not necessary. Write now for FREE book, "EARNING POWER IN DIESEL." Act Today!



## MAIL NOW FOR FREE BOOK!

UTILITIES ENGINEERING INSTITUTE, Dept. DC-36,  
2521 Sheffield Ave., Chicago 14, Ill. (Founded 1917)  
O.K. Rush, without obligation, FREE book on DIESEL.

NAME \_\_\_\_\_  
ADDRESS \_\_\_\_\_  
CITY \_\_\_\_\_ ZONE \_\_\_\_\_ STATE \_\_\_\_\_  
 Check here for information if under 17.

## Flower Coasters and Tiles PRESERVE Real FLOWERS in NEW CRYSTAL PLASTIC



"Pours like water . . .  
Sets like glass"

### NEW BOOK Shows How:

• to permanently preserve real flowers, photos, coins, shells, star fish, butterflies, etc., in Castolite. • Create exquisite jewelry • Cast beautiful figurines, plaques, candlesticks, other lovely things for gifts or to sell. Comes crystal clear or may be dyed for brilliant color effects. Can be sawed, drilled, carved.



YOU CAN DO IT—AT HOME WITHOUT EXPERIENCE. Illustrated step-by-step instructions show how to get started, what to make, to have fun, make money. Free with book, new manual "How to Make Jewelry" and proven "Home Success Plan." Send 25c to CASTOLITE, Dept. B-1, Woodstock, Ill.



## COMPLETE KIT For Handbag Repairmen, Hobbycrafters

Whether it's your business or your hobby, the Monal Kit's amazing assortment of handbag locks, turn locks, book locks, lift locks, snap locks, strap handle holders and clips, has everything you need, \$4.95 prepaid. Send 10 cents (Refunded with Order) for graphic photo of every item in the KIT.

MONAL CO. 102 WESTWOOD AVE. CRANSTON 5, R. I.

## LEARN Modern Appliance and Electrical Servicing

Revolutionary New Method shows you how—at home—in YOUR SPARE TIME! We send you complete Home Training Kits and Latest Engineered Test Equipment. You can actually earn BIG MONEY WHILE LEARNING! Many men are making \$2.50—\$3.00 and more PER HOUR! RUSH name and address for big FREE book and full details—WRITE TODAY!

ADVANCE TRADES INSTITUTE, Dept. 142  
5944 NO. NEWARK AVE. CHICAGO 31, ILL.



## Make BIG MONEY! RAISE CHINCHILLA RABBITS!

Cash Markets Supplied for Your Production  
FREE - Illustrated Booklet - WRITE TODAY!  
ROCK HILL RANCH, SELLERSVILLE 26, PA.  
World's Largest Breeder of Chinchilla Rabbits

## ENGINEERING DEGREE IN 27 MONTHS

INDIANA TECHNICAL COLLEGE

B. S. DEGREE, Aeronautical, Chemical, Civil, Electrical, Mechanical and Radio Engineering (inc. TV and Electronics). Drafting, 1-yr. G.I. Gov't. approved. Low rate. Start board. Large industrial center. Students from 48 states, 21 countries. Demand for graduates. Enter March, June, September, December. Write for catalog, 1624 E. Washington Boulevard, Fort Wayne 2, Indiana.

## Say You Saw It in Popular Mechanics

# Telephones

Desk Stand Style

Slightly used and in excellent condition. Many Valuable Uses—  
Inter-house phones  
Loud Speakers  
Microphones  
Educational purposes  
Toys, etc.

Postpaid in U.S.A.  
Complete, ready to use. Wiring Diagrams Furnished. Two complete for only \$5.00.

TELEPHONE LAMP KITS  
Including Telephone, lamp, dippers, push switch, tool & plug together with illustrated instructions \$2.50 postpaid (inside not included).

MICROPHONE Dept. X-1102  
1760 W. Lunt Ave., Chicago 26, Ill.

# New! ALL PLASTIC QUICKIE KITS



ALL  
FOUR  
ONLY  
\$3.16

1904 OLDS 69¢ 1914 REGAL 89¢  
1911 MAXWELL 69¢ Famous Antique 1913 MERCER 89¢

Autos you can assemble in 5 minutes  
NO SANDING - NO CARVING  
FOR COLLECTORS OF ALL AGES  
At your Hobby, Toy and Department  
Store OR SEND DIRECT - All 4 Kits for  
\$3.16 plus 25¢ for postage and handling.

SCRANTON HOBBY CENTER **Lil' OLD TIMERS**  
Dept. B-14 • 329-331 Adams Ave., Scranton 10, Pa.

## IS YOUR ENGLISH HOLDING YOU BACK?

Mistakes in English may be holding you back from a better job and social advancement. You can gain greater confidence, win new friends, make more money—through BETTER ENGLISH. Free 32-page booklet tells how you can become a more effective speaker, writer, and conversationalist without going back to school. New, easy method takes only 15 minutes a day. For your FREE booklet, send a card or letter. No obligation—no salesman will call.

CAREER INSTITUTE, Dept. D-112, 25 E. Jackson, Chicago 4

**TOOTHACHE?** TOOTH GUM TOOTH DROPS  
Ask your Druggist for **DENT'S** POULTICE

**YOU CAN BUILD A VIOLIN FOR PLEASURE OR PROFIT**

Now you can build a rich toned mellow violin modeled after a famous "Strad." YOU CAN MAKE A STRADIVARIUS VIOLIN contains 2 full scale plans plus complete instructions. You work directly from the plans with no confusing scale of dimensions to translate. Detailed instructions for each step including varnishing and stringing—even shows how to build your own tools. Club bound. Order today from

**POPULAR MECHANICS PRESS . . . \$3.50**  
200 EAST ONTARIO STREET, CHICAGO 11, ILLINOIS

# Tool and Die Design Training

**\$8,000 to \$15,000 YEARLY INCOME!**

ACME training has been fully proved in practice through its fine resident schools. Acme graduates report outstanding promotions, resulting in higher salaries. Progress is sure and easy through Acme's famous "COPE" System. Prepare yourself IN YOUR SPARE TIME for a secure position of responsibility and high earnings, and qualify at a time when you will have every opportunity to rise to a position in the \$8-15,000 per year salary bracket. Be successful — Go Further Faster!

Approved Under PE550 for Korean Veterans Training

## ACME SCHOOL OF DIE DESIGN

Write Correspondence Div., "M" for Information DAYTON 2, OHIO  
R. H. JEFFERSON STREET

Come on, Buddy, Quit being a BAG of BONES Weaking LIKE I WAS

**Hi Pal!** IN 10 MINUTES OF FUN A DAY

WIN \$100.00 as I just did!

You can do ALL I did!  
I gained 25 Terrific LBS. of HANDSOME POWER-PACKED MUSCLES all Over!

I improved My HE-MAN LOOKS 1000%  
I won NEW STRENGTH  
I won NEW POPULARITY

**JIM NORMAN AFTER He Mailed Coupon**

Everybody admires Jim's build NOW He's a WINNER in ALL SPORTS

I Mailed the Coupon and got these 5 PICTURE PACKED He-Man Courses Which YOU Can NOW get FREE

Before \$1 price goes back Millions Sold for \$1.00

**YOU CAN WIN a BIG 15" SILVER CUP as I just did! with YOUR NAME engraved on it!**

1. HOW TO MAKE A MIGHTY CHEST

Come on PAL, Now YOU give me 10 PLEASANT MINUTES A DAY In Your Own Home Like Jim Did and I'll give you a NEW HE-MAN BODY for your OLD SKELETON FRAME

**NO!** I don't care how skinny or flabby you are I'll make you OVER by the SAME method I turned myself from a wreck to the strongest of the strong.

2. HOW TO MAKE A MIGHTY ARM

Develop YOUR 520 MUSCLES Gain POUNDS, INCHES FAST!

**YES!** You'll see INCHES of MIGHTY MUSCLE added to your ARMS and CHEST. Your BACK and SHOULDERS broadened. From head to heels you'll be a WINNER in EVERYTHING you tackle.

3. HOW TO MAKE A MIGHTY BACK

4. HOW TO MAKE A MIGHTY GRIP

5. HOW TO MAKE MIGHTY LEGS

**LAST CHANCE - ALL FREE COUPON!**

1. Photo Book of STRONG MEN  
2. MUSCLE METER 3. FIVE COURSES

Dept. PM-42  
Tell Me How To WIN \$100, etc.

JEWETT INSTITUTE OF PHYSICAL TRAINING  
220 FIFTH AVENUE, NEW YORK 1, N. Y.

Dear George: Please mail me FREE Jewett's Photo Book of Strong Men and a Muscle Meter, plus all 5 of your Building Courses: 1. How to Build a Mighty Chest, 2. How to Build a Mighty Arm, 3. How to Build a Mighty Grip, 4. How to Build a Mighty Back, 5. How to Build Mighty Legs—New all in One Volume "How to Become a Mighty HE-MAN" ENCLOSED FIND 10¢ FOR POSTAGE AND HANDLING (no C.O.D.'s).

NAME \_\_\_\_\_ AGE \_\_\_\_\_  
ADDRESS \_\_\_\_\_  
CITY \_\_\_\_\_ ZONE \_\_\_\_\_ STATE \_\_\_\_\_

**EXTRA FLASH THAT GETS THE BIG ONES—  
HAWAIIAN WIGGLER #2  
WITH THE NEW WEEDGUARD SPINNERS**



"The old No. 2 Hawaiian has been my favorite for years," says R. L. "Bob" Farrow, Monroe, La. "but the new model with the weedguard spinner is really a world-beater. It dug this 28-lb. string of Large-mouths out of the weeds, brush and stumps of Black Bayou Lake in short order. The biggest weighed 5-1/4 lbs." Casting size only, choice 4 colors \$1.25 each. Also available without weedguard spinners, \$1.15 each.

**SHALLOW RUNNER**

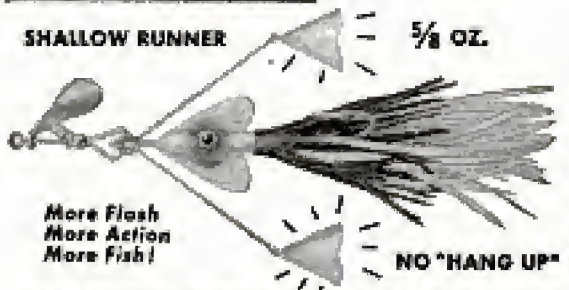

More Flash  
More Action  
More Fish!

**FREE** WRITE TODAY FOR YOUR BIG FREE NEW 1954 COLOR CATALOG OF BAITS—FULL OF PICTURES OF CATCHES  
**FRED ARBOGAST COMPANY, INC.**  
2222 WEST NORTH STREET • AKRON 3, OHIO

**TOP SPEED  
For RACING or FUN**



These famous AQUA-JET propellers won twice as many times in the "National Stock Outboard Championship" as all other wheels, custom built included. Inexpensive stock propellers, requiring no alteration of lower unit, each specifically engineered for motor used (7 1/2 to 50 HP). Write for FREE 1954 catalog—the Outboarder's Bible. Shows how to get better performance from any boat and motor combination—for pleasure or racing—also fine line of boat trim. Michigan Wheel Company, Dept. P-72, Grand Rapids 3, Mich.

**IT PAYS to know—  
WATCHMAKING**

Why spend all your life as dull or backbreaking work? Watchmaking is light, clean, fascinating. Ideal for handicapped. Lifelong livelihood. Learn the quick Swasey way at home or Chicago school. Modern methods, step-by-step. No previous experience needed. Send for FREE sample lesson. No obligation.

**APPROVED FOR VETERANS**

Chicago School of Watchmaking also offers personal attendance courses in advanced horology, engraving, jewelry repairing, diamond and stone setting. Successfully taught since 1908.

**CHICAGO SCHOOL OF WATCHMAKING**

2330 Milwaukee Ave., Dept. 124, Chicago 47, Ill.  Veteran  
Send me FREE sample lesson  Home study  Resident school

Name \_\_\_\_\_  
Address \_\_\_\_\_  
City \_\_\_\_\_ Zone \_\_\_\_\_ State \_\_\_\_\_

**RARE  
DAISIES**

Glorify your garden with the most gorgeous hardy daisies grown—pink chastas, blue fringed daisies, Robinson's giant painted daisies, double fringed chastas, and May chastas. All included in our new and finer 1954 catalog. Roses, Mums, Tulips, Evergreens, Fruits, etc. Our 105th year.

**FREE CATALOG**  
Send for your copy today

**SPRING HILL NURSERIES,**  
Dept. L-38, Tipp City, Ohio

**UP TO 6 MILES MORE PER GALLON**  
Reported by Hundreds Using  
**MIRACLE ACTION TUR-B-LIZER**

Carburator specialists say Tur-B-Lizer is best patented improvement they have seen. Tested in millions of miles of driving in cars, trucks and tractors. Easily installed. Send \$3.00 for six cylinder type, \$4.50 for eight cylinder type. Try Tur-B-Lizer for 30 days. If you are not enthusiastically satisfied as claimed by hundreds of users, your money will be promptly refunded.

Mechanics-Salesmen: Make big money selling and installing. Write for full facts.

**UNIVERSAL TUR-B-LIZER CO.**  
821 E. STATE ST. MILWAUKEE 2, WISC.

**TOOLS WHOLESALE**

**MAKE EXTRA MONEY**

Start Your Own Business. Sell tools to your friends, neighbors, Part Time-Full Time.  
**A MILLION DOLLAR INVENTORY AT YOUR FINGERTIPS.**

Send \$1.00 for Dealer's Card and Wholesale Catalog

**SILVO HARDWARE CO., Dept. M, 108 Macker St., Phila. 6, Pa.**

Stanley, Millers, Falls, Plumb, Dixon, Wiss, and others at 50% to 50% off.

**MONEY in DONUTS**

Make new greaseless donuts. Start in kitchen. No smoke. Sell stores. Cash daily. No experience necessary. Free recipes. No obligation. Write for

**MARTIN RAY CO., 3605 SO. 15th AVENUE, MINNEAPOLIS 7, MINN.**

**BOYS' ARCHERY MATERIALS**

**FINE BOWS and ARROWS  
SELECTED RAW MATERIALS**

**Catalog 5c** Send for it  
**HAND BOOK—Illustrated**  
Instructions on Making and Shooting Archery Tackles—75c

**L. E. STEMMER CO.**  
Manorville (Box 3) L. I. N. Y.

**INSURED TIRE SERVICE  
POPULAR BRANDS**

**FREE** INSURANCE POLICY given with each used tire sold. We guarantee the amount of service you pay for.

Tube Given Free with Each Used Passenger Tire Upon Request

**YOU CAN'T LOSE!!**

Super Quality	Rugged Performance	15 Months Insured Service
600x16 \$4.98	670x16 \$8.25	700x16 \$8.25
680x15 4.98	670x15 8.35	670x15 8.25
680x16 5.48	700x15 8.40	670x17 4.75

Supreme Quality	Nothing Finer	30 Months Insured Service
450x20 5.95	450x21 6.25	700x15(B) 18.95
600x16 5.65	650x15 5.75	600x20 15.95
650x16 5.85	670x15 5.95	600x20 20.45
700x16 7.75	700x15 5.75	700x20 26.75
750x16 12.80	710x15 6.50	1000x22 19.50
650x17 5.75	760x15 6.95	1100x22 24.75
825x17 5.45	820x15 7.80	1200x20 23.50
640x15 5.75	475x15 5.75	1300x24 22.75

Specialty shipments on Mail Orders. F.O.B. Chicago. Insurance policy sent with each order. Deduct 10% on orders for 2 or more used tires. Send CHECK or MONEY ORDER—No C.O.D.'s.  
445 W. 37th St., Dept. PM-19, Chicago 9, Ill.



# HEARING-BAD?

If so, you will be happy to know how we have improved the hearing and relieved those miserable head noises, caused by catarrh of the head, for thousands of people (many past 70) who have used our simple Elmo Palliative Home Treatment in the past 16 years. This may be the answer to your prayer. **NOTHING TO WEAR.** Here are **SOME** of the symptoms that may likely be causing your catarrhal deafness and head noises: Head feels stopped up from mucus. Dropping of mucus in throat. Hawking and spitting. Mucus in nose or throat every day. Hearing worse with a cold. Hear — but don't understand words. Hear better on clear days. Worse on rainy days. Head noises like crickets, bells, whistles, clicking, escaping steam or many other sounds. If your condition is caused by catarrh of the head, you, too, may likely enjoy such wonderful relief as many others have reported. **WRITE TODAY FOR PROOF AND 30 DAY TRIAL OFFER.**



**THE ELMO COMPANY**  
DEPT. 4PM2 DAVENPORT, IOWA

## WANT TO Write Stories

**FREE BOOK** tells how you learn at home

### Articles? Mysteries?



Would you be willing to spend a few hours a week learning to write so you may earn \$100-\$1200 a year part-time? Or many thousands full-time? **FREE** book, "Art of Writing Salable Stories" tells how to get started writing short stories, radio-TV scripts, articles, business items. Many students earn while learning (Graham Dour sold one story to Post, CBS Radio and NBC-TV). Endorsed by famous authors, scores of successful graduates; approved for veterans. Send today for **FREE** book (no salesman will call). **PALMER INSTITUTE OF AUTHORSHIP, Since 1917**  
1680 N. Sycamore Hollywood 28, Calif. Desk T-24

# STOP BURNING OIL!



**LOSING POWER WASTING \$\$\$**

When your car "eats-up" oil, loses that get-up-and-go power, has poor gas mileage, it's a sure sign that you have worn rings, pistons, and cylinder walls in your engine. This is robbing you of driving pleasure and valuable \$\$\$ to the tune of \$250 every 10,000 miles in oil, gas, and repair bills.

### WHAT CAN YOU DO ABOUT IT?

You can either have an expensive overhaul job done or offset this wear with a

### RING-RE-NU MOTOR RECONDITIONER KIT

It's the inexpensive, proven answer to a worn engine. This terrific 1-2 combination restores power and zip to your car without expensive repair work, reduces oil burning, slashes gas consumption, brings back that "new car" performance to your car.

#### HERE'S HOW THIS DOUBLE VALUE KIT PERFORMS!

- 1. PYR COMPOUND**—is a hard hitting engine reconditioner that removes sludge, tars, sticky greases from a tired, worn engine. Pour in carburetor, idle engine. Leaves rings, valves, pistons whistle clean, ready for...
- 2. RING-RE-NU**—the amazing compound which when squeezed by tube on your pistons forms a tough, pliable, self-expanding seal on rings and pistons to compensate for wear.

**RESULT!**—You get power-packed, economical driving pleasure. Good for 10,000 plus miles. Adds years to the life of your car. Guaranteed not to harm the finest engine. Takes only 30 minutes to install.

#### Read ACTUAL PROOF From One of 100,000 Satisfied Users!

Carlisle Owner, E. L. G., Lawrence, Mass. writes — "My Cadillac was burning 3 qts. of oil every 100 miles. I have now travelled 400 miles since installing the kit. Haven't used one drop of oil. Further my gas consumption has been cut in half. I'm more than pleased with results — best investment I ever made."

#### NOTE! DON'T BUY HALF A TREATMENT!

Ring-Re-Nu is more than just a seal—it's a complete 1-2 combination. PYR to clean your engine. RING-RE-NU to seal in that "new car" power.

1 tube kit \$4.95 post. treats all cars except large 8 cyl. autos which require special 2 tube kit at \$8.95 post. sold with money back guarantee. C.O.D.'s accepted. \$1 deposit required. Bal. and postage on arrival. For economical, power-packed, new car performance — rush order to:



Only \$4.95

three folds available on request

### RICHIE DISTRIBUTING, INC.

1912 MADISON AVENUE • DEPT. A2 • CLEVELAND 7, OHIO

RING-RE-NU... GOOD FOR YOUR CAR — GOOD FOR YOUR POCKETBOOK

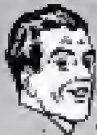

I MADE \$14 PER DAY While still learning!

T. L. R.—WEST VIRGINIA



I MADE \$800 IN 3 MONTHS While taking your course!

F. V.—NEW YORK

Get into the

## ELECTRIC APPLIANCE REPAIR & SERVICE BUSINESS



**OPEN YOUR OWN SHOP**  
As soon as you enroll, I send you my New Book "How to Open Your Own Business" at no extra cost. PTS training is more than a home study course in electric appliance repair and service. It gives you the "know how" on the operation of your shop from a business standpoint: What to charge, how to get customers. Everything possible is done to start you on the road to success.

**WE TEACH YOU:**  
Electric motors, house wiring, refrigerator, auto ignition, automatic washers, garbage disposals, fluorescent lights, irons, cleaners, etc., at home.

**SPARE OR FULL TIME**  
You can actually increase your income while still learning—spare or full time  
**ACT NOW**  
Want a good-paying business—a job in a fast-growing industry? Send now for your **BIG FREE BOOK**—"My Plan for your Success." Get started NOW

**EASY TO LEARN**  
Men of all ages, yes, even the man of 60 can get into this expanding field. A **REAL OPPORTUNITY** for the practical man who wants the **BETTER THINGS IN LIFE.** The easy PTS Home Study Plan prepares you for greater earnings NOW!

I SEND YOU A

**BIG KIT of TOOLS at No Extra Cost**



**SEND FOR THIS FREE BOOK**



### MAIL THIS COUPON TODAY

**PACIFIC TRAINING SCHOOL** H. T. ARMSTRONG  
7219 So. Broadway, Dept. P-542 Los Angeles 3, Calif.

Please send me, without obligation, your free booklet and details.

Name \_\_\_\_\_  
Address \_\_\_\_\_  
City \_\_\_\_\_ Zone \_\_\_\_\_ State \_\_\_\_\_

## FREE-A BUSINESS OF YOUR OWN

- No Store to Equip • No Training Period
- No Investment • No Stock to Buy

### SUBSTANTIAL MONEY-MAKING OPPORTUNITY

Your Total Cost  
—a 3-cent stamp



All I ask of you is that you like to sell. If you can make a fair living selling anything else, I'll show you how to make tremendous profits as a MASTER Work Garment Salesman, and I'll furnish everything you need, free of charge.

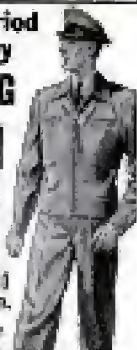

MASTER Work Garment salesmen are cashing a harvest of dollars in hundreds of communities all over America. Men who—a year ago—didn't know what a work garment was, are now buying homes and cars with the profits from a MASTER Dealer franchise. Your sales are volume sales, repeat sales, steady-income-to-you sales. Every business in the country is a prospect for uniforms and work clothes with name-and-advertising embroidery. Stores can't compete. Master brings you the world's finest, most complete quality lines in all new styles and fabrics. I supply everything you need—samples, sales material and guidance. Thousands making big money easily. Your territory may be open. Write me today for full details; a postcard will do.—Del. V. Bergstrom, Pres.

**GEO. MASTER GARMENT DIV.**  
194 WATER STREET, LIGONIER, INDIANA



## ITALIAN ACCORDIONS AT LOWEST WHOLESALE PRICES

"PAY AS YOU PLAY"

Small Down Payment  
As Little As

**\$10** per month

DIRECT from Importer to You!

SATISFACTION GUARANTEED, or your money back! NOW you can save up to 50% by direct purchase from America's leading distributor of famous genuine ITALIAN ACCORDIONS. TRADE-INS ACCEPTED

Send for FREE Illustrated Catalog!

5-DAY FREE TRIAL

ACCORDION MANUFACTURERS & WHOLESALE OUTLET

2003 West Chicago Ave. Dept. R 24, Chicago 22, Ill.

Say You Saw It in Popular Mechanics

## High School at Home

### Many Finish in 2 Years

No classes. No time wasted going to and from school. Progress as fast as your time and abilities permit. Standard H. S. texts supplied. Thousands enroll each year in this 57-year-old school. Send for FREE descriptive booklet.

**AMERICAN SCHOOL, Dept. H245**  
Drexel at 58th St., Chicago 37, Ill.

Without obligation, please send FREE descriptive booklet.

Name \_\_\_\_\_

Address \_\_\_\_\_

## Success Requires Training! LEARN AIR CONDITIONING and REFRIGERATION

This great, modern industry is alive with opportunities for trained men. Installation, maintenance and servicing of home and industrial equipment is a well-established, paying trade and business. Now mechanically inclined men can get practical instruction in spare time at home, plus quick shop practice at U. E. I. (founded 1927).

### IMPORTANT FACTS FREE — Write today

Find out all about these interesting opportunities without obligation. Send a postcard or short note right now.

**UTILITIES ENGINEERING INSTITUTE, Dept. C-9**  
2525 SHEFFIELD AVENUE CHICAGO 14, ILLINOIS



## 129 NEW FULL SIZE PATTERNS \$1.00

EASY-TO-USE PATTERNS (just trace on wood, cut out, paint) on 129 Unusual Novelties, Girds, Lawn Figures up to 22 in., Action (ready-to-go-round) Windmill, Toys, Useful Gadgets, etc. Artist drawn. Money Back Guarantee. Clip this ad and mail with \$1. bill TODAY.

CRAFTPLANS, Dept. A-230, 1321 S. Michigan, Chicago 5

## Want a COLLEGE EDUCATION in Engineering or Liberal Arts — on an economical plan?

More than 50 colleges now offer you a remarkably practical plan of "Learn while you earn". It no longer requires a lot of cash to obtain a college education in Engineering or Liberal Arts. These colleges help secure a part-time job in the field you desire while studying for a college degree in that field. Thousands of men are doing just this, today! Industry and other fields want to help you gain that efficient "know-how". They need you now. GI's get even further aid. Send \$1.00 TODAY for a copy of our easy-to-follow, complete data booklet entitled "College For Everyone". No C.O.D.'s please.

COLLEGE AIDS P. O. Box 157 E. Pasadena 8, Calif.

**RADIO** Engineering. All phases radio & electronics theory & practice; television; FM; broadcasting; servicing; aviation; marine & police radio. Prepare for high pay: 18-month course. Graduates in demand by major companies. Enroll Jan., March, June, Sept. Regular campus life. Write for catalog. **VALPARAISO TECHNICAL INSTITUTE, Dept. D, Valparaiso, Ind.**

## Become a MENTAL SUPERMAN

OVERNIGHT! Know everybody! Revolutionary "MEMO-PROP" does all your thinking! It's uncanny! Unprecedented! FREE LITERATURE! **BISSO STUDIO, BOX 1727MC, HOLLYWOOD 26, CALIF.**

## STUDY INDUSTRIAL DESIGN

You can train at Art Center School in California with practicing-professionals for upper-level jobs in INDUSTRIAL DESIGN. Recent graduates have been added to the staff at General Motors, Chrysler, Raymond Loewy, Henry Dreyfuss, etc. Majors in transportation, general product design, structures, community development, furniture design, packaging, display, 4-year degree courses. Learn to combine imaginative design with technical proficiency, coordinate utility and beauty. Stimulating environment. Field trips. Advantages of mild Southern California climate and nearby holiday spots. Cost. Placement service. Write for catalog.

**ART CENTER SCHOOL, Edward M. Adams, Director**  
5593 WEST THIRD STREET, LOS ANGELES 8, CALIFORNIA

## HELPFUL BOOKS

Send post card asking for FREE catalog  
Popular Mechanics Press, 200 E. Ontario, Dept. 601, Chicago 11

## KING MIDGET AUTO

Operate it for 75¢ per week. Amazing performance. Surprising comfort. All steel construction. Ready to run or assemble. It goes with car built together parts. Older Agents wanted. Send 25¢ for detailed literature or \$1 (returned first order) for actual assembly book and service manual filled with photos, drawings, specifications, etc.

**MIDGET MOTORS MFG. CO., ATHENS, OHIO**



WORLD'S LOWEST PRICED 2 PASSENGER AUTO

POPULAR MECHANICS

Copyrighted material

# MAKE MONEY 90 WAYS IN PHOTOGRAPHY



**EARN WHILE YOU LEARN AT HOME**

A profitable, action-packed career or steady, sparetime income can be yours in photography. Start earning at once as you learn to make money 90 ways with your camera. Our famous, low-cost LEARN-BY-DOING method and PERSONAL guidance train you quickly, easily at home! Big FREE book gives all the exciting details. Write TODAY! Our 44th year. Also Resident Courses.

Approved for Veterans.

**NEW YORK INSTITUTE OF PHOTOGRAPHY**  
Dept. 49, 10 West 33 Street, New York 1, N.Y.



## GIANT BALLOONS

Surplus U. S. Gov't. new—overcast NEOPRENE weather, target balloons. For FUN or PROFIT. Great sport in the back yard or for parties, picnics, dances, fairs. MONEY-MAKERS. Use these balloons to attract crowds to civic events, competitions, exhibitions, trade shows. TECHNIQUE for high school and college PRIZES. All sizes are approx. Inflated size. Postage prepaid on prepaid orders. 18", 3 for \$5;—3 ft. dia. 49c—5 ft. dia. 99c—13 ft. dia. \$1.59—20 ft. dia. \$1.95

\* Calif. residents please add sales tax.

**WAR ASSETS DIV. VOLUME SALES CO.**

Dept. M-2-54 3930 Sunset Blvd. Los Angeles 28, Calif.

## BRAND NEW NYLON COVERS

for outdoor storage of cars, boats, machinery, equipment, etc. Strongest, lightest cover ever made. New DuPont Nylon with 1 side rubberized and the other of soft nylon, cannot scratch car surface. Will not harden, crack or mildew. Secured with heavy elastic and brass grommets. Protection against wind, rain, sun, snow, frost, etc. 10-day money-back guarantee. Material very heavy (3 times stronger than regular plastics). Olive green color.



Give Larger Size for Caddy, 1.1nc., etc. \$2.95 extra Model.

Nylon tears to order. Heavier weight, double Standard \$17.95 plus 20c quoted, 2 sz., brass grommets. 200 sq. ft. Size postpaid

DEFENDER TEXTILE CORP., 425 N'way, Dept. PM-2, N. Y. 13, N. Y.

## LEARN WATCH REPAIRING

**AT HOME** Modern, original instruction. Prepare for a position or start in business after completing our course. Write Today! WISCONSIN SCHOOL OF WATCH REPAIRING 789 N. Milwaukee St. Dept. M Milwaukee 2, Wis.

## EASY TO LEARN CODE

Learn to increase speed with an Instructograph—the Radio-Teletype Code Teacher that takes the place of an operator-instructor and enables anyone to master code without further assistance. Available tapes from beginners alphabet to typical messages on all subjects. Speed range 5 to 40 WPM. Always ready—no GRM. Thousands have "acquired the code" with the Instructograph System. Write today for convenient rental and purchase plans.



**INSTRUCTOGRAPH COMPANY**  
4701-V Sheridan Road, Chicago 40, Illinois

**SAY YOU SAW IT IN POPULAR MECHANICS**

This FREE Catalog Brings You \$60.00 A WEEK for just 3 orders a day!



No investment, no experience needed. Just show amazing cushion comfort features to friends, co-workers, neighbors in spare time. Advance commissions to \$4.00 a pair, 310 styles for dress, work, sport. Tremendous values for men, women, children. Satisfaction guaranteed. Show samples supplied without cost. Write TODAY for FREE new 84 page Catalog and full details.

TANNERS SHOE CO., 373 Boston 10, Mass.

- \* Plus Extra Cash Bonus
- \* Plus Paid Vacation
- \* Plus \$25.00 Reward Offer

# For HEADACHE HELP

# Take Alka-Seltzer

Reg. U. S. Pat. Off.



Trade Mark

ON DISPLAY AT ALL DRUG STORES

## Get That FEEL BETTER FEELING

Fast! Tests prove the system absorbs more of the pain-reliever faster from Alka-Seltzer.

FIRST AID for ACID INDIGESTION COLD DISCOMFORTS

Made By MILES LABORATORIES, INC., ELKHART, INDIANA

## Prints Postal Cards!

**FREE** Use on 30 Day Trial! Send name today for facts and FREE Illustrated Book of unique advertising plans and money-making ideas for your business. Learn how others are boosting sales with post card ads... easy with Cardmaster.



Cardmaster Co., 1920 Sunnyside, Dept. 1342 Chicago 40, Ill.

"My selling time actually shows me a profit of

**\$20 TO \$25 AN HOUR**

with Science's New Midget Miracle, the  
**PRESTO Fire Extinguisher**

says M. R. Stanley of Montana. Many others "cleaning up"—so can YOU!



M. R. STANLEY

THIS is an amazing new kind of fire extinguisher. Tiny "Presto" (about the size of a flashlight) does job of bulky extinguishers that cost 4 times as much, and are 8 times as heavy. Ends fires fast as 2-

seconds. Fits in palm of hand. Never corrodes. **Guaranteed for 20 years!** Sells for only \$3.98! Almost 2 million already sold!

Show it to civil defense workers, owners of homes, cars, boats, farms, etc., and to stores for re-sale. Make good income. C. S. Mellous made \$175 in just first 5 days. C. Kama, \$1,000 a month. Write for **FREE Sales Kit**. No obligation.



Science's New Midget Miracle—**"PRESTO"**

**MERLITE INDUSTRIES, Dept. 52**  
114 East 32nd St., New York 16, N. Y.

(In Canada: Mops Co., Ltd., 371 Dowd St., Montreal 3, P. Q.)

(If you want a regular Presto to use as a demonstrator, send \$2.50. Money back if you wish.)

# MEN WANTED

to train as **MACHINISTS,**  
**TOOL MAKERS & DESIGNERS**

There is a critical shortage of trained machinists, tool makers and designers. The Industrial Training Division of the American Technical Society, an Educational Institution chartered not-for-profit, now offers to train men at home in their spare time to get the necessary trade related knowledge that leads to increase in pay and job security. No classes to attend. Texts furnished. Low tuition rates. Diploma awarded. For full details check the line of work in which you are interested and mail today to Dept. PM-2, American Technical Society, 850 E. 58th Street, Chicago 37, Illinois.

- |  |   |
|--|---|
| <input type="checkbox"/> TOOL MAKING           | <input type="checkbox"/> TOOL DESIGN        |
| <input type="checkbox"/> MACHINIST             | <input type="checkbox"/> DRAFTING           |
| <input type="checkbox"/> PRODUCTION SUPERVISOR | <input type="checkbox"/> BLUE PRINT READING |
| <input type="checkbox"/> MATHEMATICS           |   |

**250 POWER . . . .**



**Complete Telescope Lens Kit** only **\$3.49** postpaid

Conquer Space, Explore the Universe, Planets, Moon Craters, New Stars, etc. Complete Lens Kit consists of 80 inch focal length ground and polished objective lens, eyepiece lenses for 50 POWER, 100 POWER, 150 POWER, 200 POWER, 250 POWER, and all necessary lens fittings. Easy to make from simple step by step instructions. (Tripod and mount not included.) Money back guarantee.

**BUSSE SALES CO., Hartford, Conn., Dept. PM 18**

## FREE BERRY'S NEW POULTRY BOOK



Generously illustrated, describing **DAY-OLD** and **4-WEEK CHICKS**. 50 varieties, based on **AMERICA'S FINEST**; also Ducks, Geese, Outlaws. **ORIGINAL BERRY'S FARM**, for over 30 years. Beautiful book and **LOW PRICE LIST FREE**. stamps appreciated. **BERRY'S POULTRY FARM, Box 25, Clarinda, Iowa**

# Save Hundreds of Dollars On Home Repairs . . . .

Add to Your Home's Beauty and Comfort  
. . . Increase Its Selling Price

Here is the best word in dependants, money-saving help for the homeowner. *Guide to Home Repairs*, written by the editors of *Popular Mechanics*, gives you the know-how you need to repair and maintain plumbing; install and repair wiring; paint and decorate; install insulation, etc.

**Step-by-Step Instructions Tell How — Pictures Show How**  
First you read how to do it in the famous *Popular Mechanics* "Written So You Can Understand It" style and then hundreds of photos, drawings and diagrams show you how it is done. Nothing is left to the imagination. Now you can lay floor tile and linoleum, repair doors and windows, tuckpoint, repair and install gutters, etc. Order your copy today. If it isn't entirely satisfactory you may return it in seven days for a full refund.

192 Pages  
646 Illustrations  
**\$2.50**



**POPULAR MECHANICS PRESS, Dept. HR-1**  
200 E. Ontario St., Chicago 11, Ill.

Send at once my copy of *Guide to Home Repairs*. My remittance for \$2.50 is enclosed. If it isn't satisfactory I may return it in 7 days for a full refund.

NAME \_\_\_\_\_

ADDRESS \_\_\_\_\_

CITY \_\_\_\_\_ ZONE \_\_\_\_\_ STATE \_\_\_\_\_

Check here for C.O.D. shipment (U.S.A. only). Postage extra.

SEE HOW  
EASY IT IS  
Step by Step!



**BE AN ARTIST**  
Enjoy a Profitable Career  
or a Satisfying Hobby

We can teach you Commercial art, Painting, Cartooning—in one complete home study course. Enjoy a job as an artist in advertising, television, publishing, etc. You can become your own boss, work at home, earn money in spare time. Many students even earn while learning by lettering signs, making simple posters, etc. For 40 years WSA has trained thousands of men and women for successful art careers and enjoyable hobbies. No previous art experience necessary; our method is practical and easy to follow. You get two art outfits. **FREE BOOK**, "Art for Pleasure and Profit," describes course, quotes graduates, lists commercial art opportunities. Write today. No salesman will call.



**WASHINGTON SCHOOL OF ART**  
Studio 122N, Washington 5, D.C.

Send free book  ART CAREER  ART HOBBY

Name \_\_\_\_\_

Address \_\_\_\_\_ Age \_\_\_\_\_

City, Zone, State \_\_\_\_\_

**AT LAST... A NEW  
AUTOMATIC**

# Underground Sprinkler System

**EVERY HOME-OWNER CAN AFFORD!**

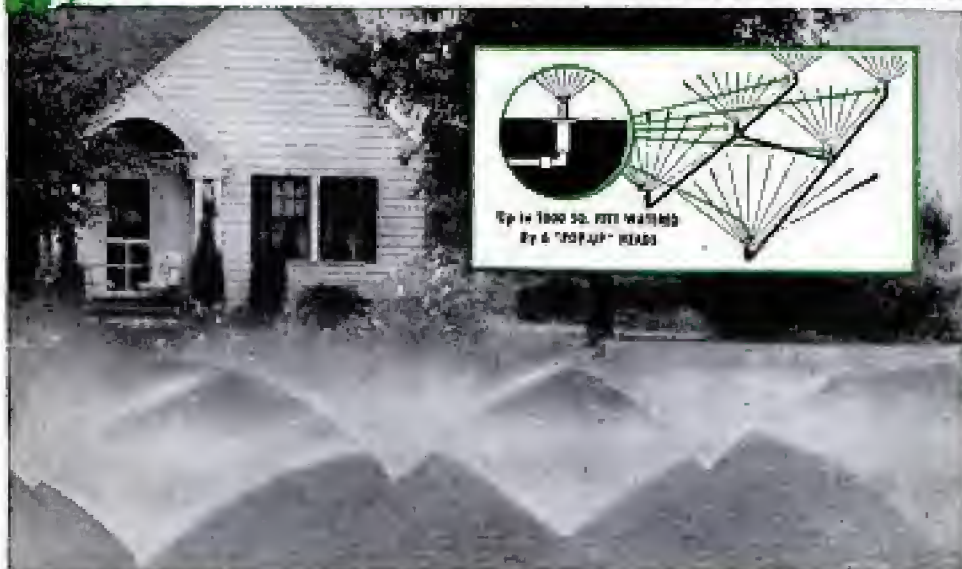

AS LOW AS  
**\$59<sup>50</sup>**  
COMPLETE

**EASY TO INSTALL  
IN A FEW HOURS  
without damage to  
Lawn or Garden  
ORDINARY WRENCH  
ONLY TOOL NEEDED**

EVERSPRAY INSTALLED AT NORTH ACRES GARDENS, ANDERSON, INDIANA

## SALES GOING CRAZY COAST TO COAST!

### Salesman Demonstrates EVERSPRAY on Prospect's Own Lawn—in Less than 10 Minutes!

Salesmen! Get in at the very beginning of the season. Make 1954 the biggest money year you've ever known. You can't miss with EVERSPRAY and here's why. EVERSPRAY is a real underground Sprinkler System. It's built exactly like those you see on million dollar estates. Yet it's priced so low that even the owner of the most modest home can afford it! It's a system that ends forever the drudgery of hand sprinkling. EVERSPRAY never gets out of order—nothing to rust, rot, or wear out—never needs repairs—doesn't cost a penny for upkeep. As trifling cost, it gives the home-owner the beautiful lawn he has always dreamed of, but could never have until now.

#### NOTHING ELSE LIKE IT

EVERSPRAY is not an untried gadget. It is a proved and tested Sprinkler System that appeals instantly to every home-owner. And it's one of those terrific money-making fast-sellers that appeals to top-flight Salesmen—men accustomed to selling "big-ticket" Home Improvement Products.

Any man who calls himself a Salesman can really clean up with EVERSPRAY because every home-owner is a prospect. He wants what you can give him with EVERSPRAY—the beautiful lawn he has always wanted—a lawn that is the envy of everyone who sees it. Best of all, the owner installs EVERSPRAY himself—or you can do it for him and collect an extra fee for this extra service. An H.C. Lewis of Great Bend, Kansas writes: "The three

EVERSPRAY Systems we installed were up to your promises in every way and water even a greater area than said. One man and myself assembled and installed all 3 systems in 1 afternoon!"

#### \$60 A DAY—WITH "JACK POT" PYRAMID PLAN

In the New Automatic EVERSPRAY you've got your hands on the biggest Spring, Summer and Autumn seller ever offered Salesmen. When most lines are dying because of hot weather, EVERSPRAY is hitting the very peak of the Big Money selling season! Our sure-fire "Jack-Pot" Pyramid Sales Plan turns your first sale into TEN or more. Then EXTRA orders start pouring into your hands automatically—with little effort on your part. It's a "push-over" for any good salesman. You make \$20.00 on every order, a net of \$80.00 on only 3 sales a day!

#### FREE! MAIL COUPON FOR FULL PARTICULARS

Limited space does not permit my giving you full details here. But I'll rush complete information to you by return mail if you'll send me the coupon now. Don't lose a minute in getting the facts. Time is precious, so act promptly. Fill in and get the coupon in the mail right now. It may well prove to be the most profitable step you have taken in your entire selling career. —John Oakman, Sales Mgr.

### Only EVERSPRAY gives Home Owners these EXCLUSIVE Features:

**ELECTRONIC, AUTOMATIC** Device turns water ON at pre-determined hour then shuts water OFF automatically. Waters lawn regularly even when owner is on vacation.

**"POP-UP" Spray Heads** and all other parts made of SOLID BRASS. Six heads water up to 1000 sq. ft. of lawn. Finger-tip adjustment gives any desired spray—from fine mist to heavy rain.

**AUTOMATIC DRAIN VALVE** makes entire System absolutely "Freeze-Proof" even in zero weather.

**SPECIAL ALLOY SOLID COPPER PIPING.** Time-tested underground. This "just-right" temper permits laying pipe underground in straight lengths for maximum pressure and water flow.

**F. H. A. APPROVED.** Customer can buy for as little as \$2.00 per month.

EVERSPRAY DIVISION, 2001-09 W. Carroll Ave., Dept. 12, Chicago 12, Ill.

### Be a USER-AGENT And Get Your EVERSPRAY FREE

**Home Owners!** The very moment your own EVERSPRAY starts sprinkling, your friends and neighbors will want to know where THEY can get one, too! Just send us their orders on our User-Agent Plan and quickly get back in profits three to four times the cost of your own EVERSPRAY. Check coupon if you are interested in this Plan.

### DISTRIBUTORS WANTED

A few Big-Profit County Franchises still available. Plenty of leads provided from our Advertising in National Magazines. Please write me a letter stating what territory you want, what item or items you now handle, how many men in your present Sales Crew and any other information you care to give me. I will hold all information in strict confidence.

JOHN OAKMAN, Sales Mgr.  
EVERSPRAY DIVISION, Dept. 12  
2001-09 W. Carroll Ave., Chicago 12, Ill.

**FREE!**

- I am a Home Owner. I am interested in EVERSPRAY for my own use.  As a User-Agent.
- I am a Salesman. Please rush full details about EVERSPRAY and the new 1954 selling opportunity now open in my territory.
- I am a Distributor. See letter attached regarding territory I desire.

NAME.....

ADDRESS.....

CITY.....ZONE.....STATE.....

not everyone does as well, but E. O. Lockin, who started a business of his own, reports...

for 12 months I've averaged

**\$800 PER MONTH INCOME**

—most of it clear profit for me!

● Mr. Lockin expresses his grateful thanks for the opportunity to make a decent living on his own. Many men have discovered how to be independent, to be free of bosses and layoffs. L. A. Eagles grossed more than \$200 his first week. R. E. Traynor says, "I made \$62 gross in one day." Others report gross up to \$12,000 per year.

How much you make depends largely on you. You need no special skill, no large investment.

**No shop necessary.**

Our **ELECTRIC RUG WASHER** cleans rugs, carpets right on floor... helps to show their natural color and beauty. So efficient and safe, used by largest hotels and railroads.

You take no risk. Machines fully guaranteed. Mail coupon today for complete information including how to start making big profits in YOUR OWN BUSINESS.

**VON SCHRADER MFG. CO., RACINE, WIS.**

You, too, can start your own business. No special skill, no large investment required. Mail coupon today for interesting **FREE** book.

**VON SCHRADER MFG. CO.,**  
1210 "R" Pl., Racine, Wisconsin

Send at once (no obligation) your **FREE** booklet containing information about your **ELECTRIC RUG WASHER** and how I can start my own permanent, profitable business.

Name \_\_\_\_\_

Address \_\_\_\_\_

City \_\_\_\_\_ Zone \_\_\_\_\_ State \_\_\_\_\_

Say You Saw It in Popular Mechanics

Make Silver Jewelry like this...

It's easy — No special tools or soldering required

Make attractive silver pins, bracelets, necklaces for yourself or as gifts. A fascinating hobby. Mail the coupon for **FREE** work sheets giving full "how-to" directions, list of materials, etc.

**HANDY & HARMAN** Craft Service Dep't.  
82 Fulton Street • New York 38, N. Y.



Without obligation please send me **FREE** Silver Jewelry Work Sheets 1, 2 and 3.

Name \_\_\_\_\_

Address \_\_\_\_\_

City \_\_\_\_\_ Zone \_\_\_\_\_ State \_\_\_\_\_

**GET "New Car" POWER!**



● Stop Burning Oil! ● Restore Compression! **\$3.95** post-paid

A small amount of Fisher's Compression SEAL in each cylinder bore gives you the economy of smooth, powerful "new car" performance and reduced oil consumption. Old, tired engines may not need expensive overhauling. Only takes minutes to apply—yet gives you 10,000 more miles of low-cost driving pleasure.

**SATISFACTION GUARANTEED!**

Full purchase price refunded immediately, if not completely satisfied. No solvent bath necessary. Order today! Information, Dealers inquire.

Sorry, no COD's. Free

**FISHER'S** 4756 S. Central, Dept. PM-2  
Los Angeles 11, Calif.

High Power **BINOCULARS**

**FREE 14-PAGE BOOK & CHART**



Know the facts! Learn meaning of Power, Field, Coating. Latest data. 33 Models sold on

**30 DAY FREE TRIAL**



BUSHNELL'S, 112 Bushnell Bldg., Pasadena, Calif.



**AT LAST... IT'S HERE!**

...the first war in making, workable, real life style. Inside with special plates on buttons, gold teeth, rings, necklaces, perfume, silver trays, real silverware. **FREE** book. **SEND** ME THE **INDIAN** SERIES. Send \$3 for 12 issues for

**TRUE WEST** P.O. Box 5000-PM • Austin 31, Texas

**PLEASE SEND ME**



for the time checked. I am enclosing . . .

- 1 year \$3.50
- 2 years \$6.00

name \_\_\_\_\_

address \_\_\_\_\_

city \_\_\_\_\_ zone \_\_\_\_\_ state \_\_\_\_\_

Hand this order to your newsdealer or send it to

**POPULAR MECHANICS**  
200 East Ontario St. Chicago 11, Ill.

# Now! New Comfort for **RUPTURE!**

The **HEALTH-AID** Hernia Support  
for the Active at Work or Play

Here it is! The greatest advance in years! Amazing new ease and safety if you suffer from reducible, inguinal hernia.

With this remarkable support you can walk, run, stoop, bend or stretch. Soft, sponge rubber pads, shaped to cover entire inguinal canal. Pads are held firmly in place at top and bottom for greater comfort and security.

If you have a double hernia you need it as supplied, with both pads. If you have a single hernia, Health-Aid supports both sides equally. This makes hernia less likely to occur on the unaffected side. The best way to judge is to try it at our risk. Wear it 10 days. If not satisfied with its comfort and support, return and we will immediately refund purchase price.

**CLIP COUPON AND MAIL TODAY!**



**\$4.95**

**BALANCED SUPPORT**



Health-Aid Company Dept. 5624  
P. O. Box 1035, Cincinnati 1, Ohio

Please send me Health-Aid Hernia Support. I'll pay postman \$4.95 plus C.O.D. fee. (If cash accompanies order we pay postage.) If not satisfied after 10 day trial, I'll return support for immediate refund of full purchase price.

My hip measurement is.....inches (3" below waist)

Name .....

Address .....

City ..... State .....

## 2 OR 4 WHEEL DRIVE FOR JEEPS IN SECONDS



### AMAZING NEW WARN HUB

Gives your 4-wheel drive Willys 2-wheel jeep, power, speed, extra mileage, passenger car performance—as well as 4-wheel power and traction! Change from 2-wheel to 4-wheel up back in seconds by turning fingertip control on hubs. Warn hubs reduce wear on front axle assembly and front tires, eliminate shimmy, increase gas mileage up to 6 miles per gal. Unconditional Money Back guarantee. \$45.00 pair prepaid. **ALSO AVAILABLE:** Warn Standard Hub for Willys \$20.00 pr., Dodge \$23.00 pr. and Warn Automatic Hub for Willys \$120.00 pr. At Dealers or direct. **WARN MFG. CO., RIVERTON Box 6064-AZ, Seattle 88, Wash.**

Say You Saw It in  
**POPULAR MECHANICS**

## Super Powerful All Channel TV RECEPTION IN ALL DIRECTIONS

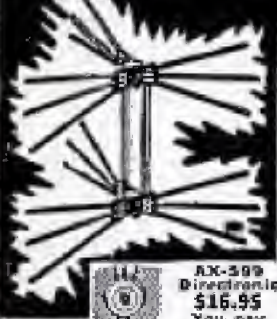

### ROCKET DIRECTRONIC MOTORLESS TV ANTENNA

- 360° Electronically Switched Beam
- No Motors
- No Roof
- Orientation
- No Electric Power
- No Ghosts
- Flick of Switch Clears Picture Instantly

In the city or in an ultra-fringe area, the Directronic will outperform ordinary antennas. Only the Motorless 360° Directronic TV Antenna offers "around the compass" reception WITHOUT Motors. Clarity of picture will amaze. It's so bright, so sharply defined. AX-519 "Service-man's Array" contains Hi-Pan molded insulator of extremely high tensile strength, 14 hi-tensile aluminum alloy elements, 1 set of connecting studs (3), Universal U-Clamps for masts to 1 1/2". Directronic Beam Selector, 75 feet of Tri-X Cable.

AX-519 Directronic  
**\$16.95**  
You pay postage

Do not remit more than complete purchase price. 25% deposit on C.O.D. orders, please. Money-back guarantee.

**NATIONAL ELECTRONICS OF CLEVELAND**  
363 DELCO BLDG. CLEVELAND 3, OHIO

## PREPARE FOR BETTER JOB, BIGGER PAY IN SPARE TIME AT HOME

Today, choose the job you want—and prepare for it in time you might otherwise waste. Or if you are already in the work you like best, start training now for quicker promotion and increased pay. During more than 50 years **AMERICAN SCHOOL**, has helped ambitious people to reach higher goals. Check subject that interests you and mail coupon for full information.

**AMERICAN SCHOOL, Dept. 0245, Drexel at 58th, Chicago 37, Ill.**

Without obligation, please send **FREE** and postpaid, full particulars about the subject checked below:

<input type="checkbox"/> Accounting	<input type="checkbox"/> Drafting—Building Trades	<input type="checkbox"/> Plastics Engineering
<input type="checkbox"/> Air Conditioning	<input type="checkbox"/> Drafting—Machine Trades	<input type="checkbox"/> Plumbing—Plumbing
<input type="checkbox"/> Architecture & Building	<input type="checkbox"/> Electrical Engineering	<input type="checkbox"/> Private Secretary
<input type="checkbox"/> Automobile Technician	<input type="checkbox"/> Electricity—Practical	<input type="checkbox"/> Refrigeration
<input type="checkbox"/> Better Personnel	<input type="checkbox"/> Electronics—Industrial	<input type="checkbox"/> Retail Merchandising
<input type="checkbox"/> Bookkeeping	<input type="checkbox"/> High School Courses	<input type="checkbox"/> Salesmanship—Outside
<input type="checkbox"/> Business Management	<input type="checkbox"/> Machine Shop Operations	<input type="checkbox"/> Sheet Metal Work
<input type="checkbox"/> Contracting	<input type="checkbox"/> Mathematics & Slide Rule	<input type="checkbox"/> Tool Making
<input type="checkbox"/> Diesel Technician	<input type="checkbox"/> Mechanical Engineering	

NAME.....  
Home Address.....  
City.....

**MAIL COUPON NOW**



# THIS . . . . 120 PAGE **GUIDE** FOR AMBITIOUS MEN **FREE!**



Have you had your copy?

120 pages of guidance to best-paid positions. Up-to-the-minute information for men who want to climb to the top. Tells how to get promotion, security and better pay through home study courses. This handbook "Engineering Opportunities" is free and entirely without obligation. Send the coupon. Make this your big year! Describes over ninety courses including:

Mechanical	Electrical	A.F.R.Ae.S.
Aeronautical	Radio	A.M.I.C.E.
Television	Automobile	B.S. (Pure
Building	A.M.I.Mech.E.	Science)

### --- SEND COUPON TODAY ---

Canadian Institute of Science & Technology Limited, 570 Century Building, 412, 5th Street, N.W., Washington, D.C.

Please forward free of cost or obligation your handbook, "ENGINEERING OPPORTUNITIES".

Name.....

Address.....

Course interested in..... Age.....

Canadian Address: Canadian Institute of Science 570 Garden Building, 263 Adelaide St. W., Toronto, Ont.

## FREE 1954 CATALOG WORLD RADIO LABORATORIES

"The World's Largest Distributor of Amateur Radio Transmitting Equipment."

Jam packed with bargains — everything in Radio, TV, and Hi-Fi — for Handyman, Ham, Experimenter or Serviceman!

- Pay Only 10% Down
- Easy Terms
- Liberal Trade-Ins
- Save Over 50% on Used Equipment
- Over 600 guaranteed reconditioned items.

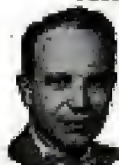

**WORLD RADIO LABORATORIES**  
3415 W. Broadway — Council Bluffs, Iowa

Leo I. Meyerson

PERSONALIZED SERVICE

### MAIL HANDY COUPON

WORLD RADIO LABORATORIES, INC. Dept. PM 2  
3415 W. Broadway — Council Bluffs, Iowa 3'x4' U.S.  
 Free 1954 Catalog  Used Eq'ry List  Radio Map 23c

NAME.....

ADDRESS.....

CITY..... STATE.....

## more jobs than graduates

**ENGINEERS**  
Amazing opportunity! If you are interested work to these 0 or pay you to write for D. J. including a complete history of work and education.

Demand for our engineering graduates exceeds supply. Effective placement! Study in this world-famed college... established 1884. New term starts quarterly. Approved for Korean Vets.

### Bach. Sc. degree in 27 months

Bachelor of Science in Mechanical, Civil, Electrical, Chemical, Aeronautical, Radio (Television), Administrative Engineering, Business Administration and Accounting. Also 36-weeks certificate courses in Surveying, Drafting, Secretarial Science. Intensive program; technical fundamentals accentuated.

Small classes; personalized instruction. For earnest, mature students whose time and budget require accelerated courses and modest costs. Preparatory courses.

Beautiful campus in friendly college town. Well-equipped, new and modernized buildings and labs. Enter March, June, Sept., Jan. Write Jean McCarthy, Director Admissions, for Catalog and View Book.



## TRI-STATE COLLEGE

424 College Avenue Angola, Indiana



### FREE WITH ORDER

Central's new complete photographic catalog, ready now! Contains complete listings of still and movie cameras and a remarkable selection of photographic accessories, many unduplicated elsewhere. Send 50c for your copy; you receive full credit on your first order.

**CENTRAL CAMERA CO. Dept. 8B**  
230 S. Wabash Ave., Chicago 4, Ill.  
Photographic Headquarters Since 1899

ADDRESS **POSTCARDS AT HOME**  
MAKE MONEY!! SPARE-FULL TIME  
write LINDO, WATERTOWN, MASS.

## TURN FUN INTO MONEY

BOOKLET TELLS HOW—H. E. A. is helping thousands to cash in on their hobbies by turning them into profitable home industries. Send \$1.00 for year's membership, descriptive booklet and credentials. Dept. B-3, Home Industries Assn. 1727 K St. N. W., Wash. 6, D. C.

## STUDY AT HOME LAW FREE BOOK! PREPARE FOR THE BAR

Write today for your copy of our FREE book, "THE LAW-TRAINED MAN," which describes the famous Blackstone home-study course in bar and business law. All needed instruction material furnished including big 14-volume law library. Bachelor of Laws (B.L.S.) degree awarded. Moderate tuition; easy monthly terms. Write today, **Blackstone School of Law 225 N. Michigan Ave. Founded 1890 Dept. 62, Chicago 1, Illinois**

# Do You Make These Mistakes in English?

MANY PERSONS say "between you and I" instead of "between you and me"—or use "who" for "whom." Every time you speak or write you show what you are. Mistakes in English reveal lack of education, refinement. Real command of English will help you reach any goal.

Only 15 minutes a day with **Sherwin Cody's famous invention**—and you can actually SEE your English improve. It teaches by HABIT—makes it easier to do it the RIGHT way. **FREE BOOK.** Lack of language power may be costing you thousands of dollars every year. See what Mr. Cody's method can do for you; it costs nothing to find out. Write now for free book, "How You Can Master Good English in 15 Minutes a Day." **Sherwin Cody Course in English, 582 Central Drive, Port Washington, N. Y.**

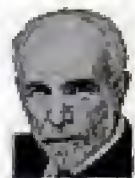

Sherwin Cody



**Over \$450<sup>00</sup> Profit!**

**I SOLD 67 D-FROST-O-MATICS IN JUST 5 DAYS SPARE TIME!**

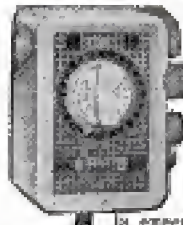
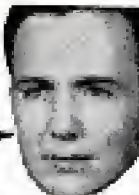

**Get the EXTRA MONEY YOU want this Easy Way!**

Amazing D-FROST-O-MATIC Makes Any Electric Refrigerator Self-Defrosting! Bill Carney is just one of thousands of alert men, all over America, who have found money-making "magic" showing housewives how amazing D-FROST-O-MATIC ends messy, time-wasting hand defrosting forever. Bill Carney's record is exceptional—but our sure-fire FREE TRIAL PLAN can pay YOU up to \$210.00 a week on just five easy sales a day! You just plug in D-FROST-O-MATIC, tell the housewife "Try it before you buy it". When she sees how D-FROST-O-MATIC saves time... work... food... and money SHE WON'T LET YOU TAKE IT OUT.

**RUSH NAME TODAY... for PROFIT Details and FREE TRIAL PLAN!**

"Anyone Can Sell Them"  
"The best place than in home, D-FROST-O-MATIC does the rest. My profit has been several times what I hoped for."  
—Bill Carney, Mo.

More than 20,000,000 prospects waiting! Rush your name and address today. We'll airmail exciting facts, proof and sure-fire Free Trial plan. No obligation. Send your name and address today.

**D-FROST-O-Matic, Dept. L-6**  
173 W. Madison St., Chicago 2, Illinois  
In Canada: **SILVEX CO., Ltd.**,  
371 Doud Street, Montreal 1, Quebec



**\$50<sup>00</sup> A WEEK IN SPARE TIME**  
— Even Without Experience!

**Take Orders For NEW EXCLUSIVE Magic Cushion Shoes**

Enjoy your own lifetime, secure, independent shoe business without investment. Steady demand and repeats. Up to \$4.00 pair advance commissions. Big bonus. Latest smart styles, top quality, heel-to-toe cushion. Complete line. It's easy to start. Write for **FREE OUTFIT** today!

**PARAGON SHOE COMPANY**  
79 Sudbury St., Dept. 20, Boston 14, Mass.



Guide to **HOME REPAIRS**

**Pays for Itself 100 Times Over**

Beat the high cost of home upkeep. Save hundreds of dollars every year on carpentry, electrical, painting, plumbing and other jobs around the house with **Popular Mechanics GUIDE TO HOME REPAIRS**. Simplified how-to-do-it instructions and 646 pictures make all jobs, inside and out, easy. Covers construction, remodeling, modernizing, repairing that you can do yourself at small cost. 100 page cloth bound book only \$2.50 postpaid. Order today under our money back guarantee.

**POPULAR MECHANICS PRESS, Dept. PM16**  
200 EAST ONTARIO STREET CHICAGO 11, ILLINOIS

**Learn LANDSCAPE GARDENING**

FOR PLEASURE OR PROFIT  
• TO START YOUR OWN BUSINESS  
• TO IMPROVE YOUR PROPERTY

A thorough interesting and constructive home training for both those who wish to become **LANDSCAPERS, DESIGNERS, & GARDENERS**, and those who wish to learn for their **OWN USE AND PLEASURE.**

**OPPORTUNITIES**  
An uncrowded field. Healthful out-of-door work for both men & women. Prepare now. Send for **FREE Information**

**NATIONAL LANDSCAPE INSTITUTE**  
Dept. P-2, 310 So. Robertson, Los Angeles 48, Calif.

**AMAZING OFFER**

# **FREE!**

**100 FOREIGN STAMPS**  
from all corners of the world  
**GUARANTEED WORTH \$1.00**  
AT STANDARD CATALOG PRICES  
AND SOUVENIR OF  
**WORLD'S RAREST STAMP**  
AND VALUABLE STAMP  
**COLLECTOR'S GUIDE**

RUSH coupon at once. We'll send you by return mail this gigantic offer — 100 stamps from Europe, Asia, Africa, South America, Near East and Far East. **GUARANTEED-WORTH \$1.00** at Standard Catalog prices. No telling what you'll find. **NO COST TO YOU!**

These valuable stamps are all genuine — unsorted and unpicked. We just scoop them out of sacks we receive from foreign missionaries, banks, etc. and rush them into packets for you.

There are beautiful big pictorials, commemoratives — stamps from great empires and tiny republics. You'll find wild animals, far-off places and famous people on these wonderful stamps — even some from "iron-curtain" countries. Since no one has examined them, you may even find real hidden treasures, worth **REAL MONEY.**

Yes, we'll rush this wonderful offer that gives you 100 stamps from **EVERYWHERE**, plus a beautiful souvenir of **World's Rarest Stamp** in color, **PLUS** our illustrated booklet "Stamp Collector's Guide" — **FREE**, if you act **AT ONCE!** Other valuable offers also included for your **FREE** inspection! If coupon is clipped, send 10c for postage and handling to:

**GARCELON STAMP CO.**  
Dept. 2 PM, Calais, Maine

**PLUS**

**SOUVENIR OF WORLD'S RAREST STAMP**  
Here is a treat indeed — and exclusive with us. Only here can you get this handsome, new folder with the beautiful reproduction in color and the fascinating story about the British Guiana stamp that sold for \$1.50 in 1853 and is worth \$50,000 today! You'll be the envy of all who see it! Display it in your album or frame it for your room!

**GET ALL 3 FREE!**

**GARCELON STAMP CO., Dept. 2 PM, Calais, Maine**  
Rush me **FREE** 100 FOREIGN Stamps, Rarest Stamp Souvenir and **STAMP COLLECTOR'S GUIDE**. Enclosed is 10c for postage and handling. **PLEASE PRINT**

NAME .....

ADDRESS .....

CITY.....ZONE.....STATE.....



## ... LIFE OF THE PARTY!

There's nothing like a set of drums in your house to bring the gang together!

Whether artist or amateurs, you and your friends will have great times and loads of fun.

BUY SLINGERLAND—the make that KRUPA uses.

Send for  
**FREE** catalog!

### SLINGERLAND DRUM COMPANY

1329 Selden Ave.

Chicago, Illinois



## ROOM FOR EVERYBODY in Old Town Oceanboat

**TAKE** the whole family for a spin in your fast, big (16-foot) outboard boat! Well-braced for the heaviest motors, planes beautifully. Safe and seaworthy. Bows flare to keep your passengers dry. Planking's painted gleaming white. Built for years of service.

**FREE CATALOG** illustrates boats for sport, for the family, and all kinds of canoes, outboard boats, rowboats and dinghies.

## OLD TOWN BOATS

Old Town Canoe Co., 142 Middle St., Old Town, Maine.

**PLEASE SEND ME FREE CATALOG**

Name \_\_\_\_\_

Address \_\_\_\_\_

City \_\_\_\_\_

State \_\_\_\_\_

# BOOKS ARE BETTER THAN EVER!

(and so is TV)

We had a hunch (about the time a lot of other publishers were gloomily predicting the end of the printed word because of TV) that nobody, but nobody, was going to sit around forever staring at the little lighted screen in their living room. We reasoned that after the novelty had worn off, people would be anxious to get back to their hobbies, workshop projects, home maintenance and repairs, and to continue to broaden their interest in this scientific and mechanical world of ours.

To prove our confidence, we even joined forces with some of the "enemy" as we continued to produce worthwhile books in these fields. For instance, we got the feeling that it was just too bad that the excellent science programs of Mr. Wizard (Don Herbert) had to vanish from the record at the conclusion of his weekly half-hour television program. We got Don Herbert to put down on paper some of his best tricks and experiments. The result was *Mr. Wizard's Science Secrets*, a book that started walking off the shelves literally as fast as we could get it to the stores. A first printing was exhausted within a few weeks . . . now we're out with the third printing (a total of 75,000 copies).

The book is an excellent gift for any bright youngster. He'll be able to mystify his friends (and learn a lot about science, too) after he reads how he can turn "wize" into water, pop popcorn with radiant energy, blow up a balloon inside a bottle, make his own telephone and telegraph systems, cause water from a faucet to bend mysteriously, make mothballs dance, etc., etc. Mr. Wizard tells not only *how* to do these tricks, but *why*. It was this that led Wilbur L. Beauchamp, professor of education at the University of Chicago, to pronounce his judgment: "It's a good book."



We think we have another best seller in *Dorsey Connors' Book: Gadgets Galore!* Miss Connors has written an excellent book, hard to label except by the blanket term, "Ideas." Some of them represent the best that she has presented on her television show over WNBQ-NBC (Channel 5). Others are brand new. Altogether they make up a collection of intriguing ideas for household short cuts, homemade gifts, etc. In an ordinary wire coat hanger, Miss Connors sees: a mail caddy . . . an earring bar . . . a rack for cups . . . a beverage holder for garden parties . . . an extra shell . . . a newspaper or book rack . . . an outdoor grill fork . . . an omelet stirrer . . . a mullin toaster. In her capable hands an aspirin tin, a stone from discarded jewelry and a little gilt paint become a Marie Antoinette pill box; while four handkerchiefs and a length of bright ribbon work into a fancy party apron. *Gadgets Galore!* is an excellent gift for any woman, whether bachelor girl or homemaker. And the handy man of the house will find much to interest him, too, in this fascinating book.

Another television star who's doing a book for us is Walt Durbahn, genial proprietor of "Walt's Workshop," a program which has a large following among home-workshop craftsmen. Walt's book, *Carpentry for the Home Craftsman*, is eagerly awaited by this group.

So TV continues to have stars and sponsors, and we continue to produce books that are sold . . . and read . . . and used. The books are as easy to obtain as your favorite program. Simply go into your favorite bookstore . . . or write



POPULAR MECHANICS PRESS  
200 East Ontario Street, Dept. 12, Chicago 11, Illinois

POPULAR MECHANICS PRESS  
200 East Ontario Street, Dept. 12, Chicago 11, Illinois

POPULAR MECHANICS PRESS  
200 East Ontario Street, Dept. 12, Chicago 11, Illinois

LOW OVERHEAD-LARGE VOLUME SALES & SMALL PROFITS BRING YOU THESE "LOWEST PRICES."

WHAT GOOD IS A TIRE WITHOUT A TUBE? TUBE FREE WITH EVERY TIRE AT NO EXTRA COST

**WHY PAY MORE!**



30 YEARS AT THIS ADDRESS AN ESTABLISHED POLICY OF CAREFUL SELECTION ASSURES YOU, MANY HAPPY MILES. BE WISE—TRY ONE—YOU'LL BUY MORE! WE WELCOME COMPETITION. NO ONE CAN TOUCH OUR QUALITY & PRICE!

YOU GET WHAT WE ADVERTISE GOOD USED TIRES — NOT RECAPS — NOT RETREADS WINTER SPECIALS—SEND THIS AD EVERYBODY 10% off ON EVERY TIRE 30 MONTHS WRITTEN GUARANTEE



600-15	\$3.42	820-15	\$4.82	600-20	\$5.52	32x8-6	\$8.02
650-15	4.12	700-15	3.82	650-20	7.02	32x6-10	9.02
700-15	4.32	670-15	3.62	700-20	7.92	900-20	13.22
650-15	3.72	710-15	4.12	750-20	8.02	1000-20	13.12
700-15	4.32	680-17	4.32	825-20	13.02	1100-20	13.02

Specialists in Truck Tires—Selected for Toughest Jobs—Tops in Value EXTRA SPECIAL—30 MONTH WRITTEN GUARANTEE—FREE TUBE

600-15	\$4.12	475-15	\$4.72	700-15(8)	\$8.02	700-20	\$10.82
600-15(6)	6.32	640-15	4.82	750-15(8)	10.82	750-20(10)	13.22
650-15	5.62	670-15	5.32	750-17	9.82	750-20(8)	11.02
650-15(6)	7.22	710-15	5.42	750-17	11.02	825-20	18.02
700-15	6.12	760-15	5.82	750-15	10.32	900-20	17.02
750-15(6)	6.62	800-15	6.32	825-15	12.62	1000-20	17.82
825-15	4.62	820-15	6.32	800-20	8.52	1100-20	17.02
850-17	4.62	870-16	6.22	850-20	9.82	1100-22	18.32
850-15	5.12	760-16	7.12	32x6(8)	11.02	1000-22	18.32
700-15	5.22	700-14(8)	7.32	32x6(10)	13.12	1100-24	19.42

ALL WHITE WALLS \$3.00 extra (Military tread) — 750-20—\$14.00

Thousands of tires shipped all over U.S.A. All tires shipped F.O.B. Phila. Send Check or M.O. with this ad. Dept. 2. **STANDARD 834 N. Broad St., Philadelphia 30, Pa.**

**NEW! CHEAP! OIL BURNER**  
AMAZING HEAT INVENTION

**\$14.75 for Stoves**  
**\$29.50 for Furnaces**

FITS IN ANY COAL STOVE, RANGE, BOILER OR FURNACE. No more shoveling Coal or Ashes. This Universal Unit makes one of the quickest, hottest, cheapest fires known. Sold on a 60 day Money-Back Guarantee. Send No Money. You will receive Agents Prices and full details by sending your name to **NORTHWEST MFG. CO., 10-B Main, Mitchell, South Dakota**

Say You Saw It in Popular Mechanics

**SEND ME**

every month so I am sure to see each new issue. Here's

\$3.50 for 1 year  
 \$8.00 for 3 years

name \_\_\_\_\_  
address \_\_\_\_\_  
city \_\_\_\_\_ zone \_\_\_\_\_ state \_\_\_\_\_ B-24

Hand this order to your newsdealer or send it to  
**POPULAR MECHANICS**  
200 East Ontario St. Chicago 11, Ill.



**"Put Your Finger" ON Any Car Trouble**

**IN A JIFFY!**

Handy New Guide Lists 2,000 Causes of Faulty Operation, Noises, Break-downs

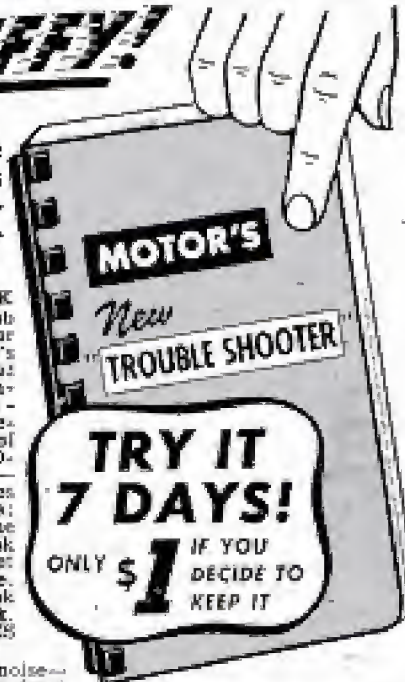

SAVE TIME AND WORK on any auto repair job by being able to "put your finger" on exactly what's causing the trouble—right from the start! New, indexed **TROUBLE-SHOOTER GUIDE**—prepared by the Editors of the world-famous **MOTOR'S** Repair Manuals—lists 2,000 specific causes of car and truck troubles; helps you find the one you're after **FAST**. Book fits right in your pocket for instant reference. Spiral binding lets book stay open while you work. Cross-section **PICTURES** also included.

If car has Fan Belt noise—turn to Fan Belt Section for 6 specific things that can be wrong. **MOTOR'S TROUBLE-SHOOTER** helps you track down noises, knocks, misses, breakdowns — faulty operation from radiator to rear end. Covers engines, clutches, brakes, ignition, new automatic transmissions, etc. Gives quick help to beginners as well as experienced repair men!

**Try Book for 7 Days — without obligation!**  
**SEND NO MONEY!**—Mail Coupon—When postman delivers book, pay him \$1, plus postage and C.O.D. charges. (Or send \$1 with coupon, and we pay shipping charges.) If not delighted return book in 7 days for full refund. **MOTOR Book Dept., Desk FV, 350 W. 55th St., New York 19, N. Y.**

**HOW TO SPOT —**

- 87 Automatic Transmission Troubles, 8 Causes of Connecting Rod Noise, 87 Checks for Poor High-Speed Performance, Lack of Power, 82 Causes for Engine "Misfire," 17 Checks for Pre-ignition or Spark Knock, 45 Causes of Excessive Oil Consumption, 14 Causes of Crankshaft Noise, 73 Checks for Clutch Trouble, 68 Causes of Head-Like Trouble, 150 Checks for Front Suspension and Steering Trouble, 81 Causes of Brake Trouble, 27 Checks for Faulty Springs and Shock Absorbers, 84 Different Types of Wheel Trimming

New "Dope" on Automatic Transmissions covers:

- HYDRAMATIC
- BUICK DYNAFLOW
- CHEVROLET POWERGLIDE
- PACKARD ULTRAMATIC
- STUDEBAKER AUTOMATIC

**MOTOR Book Dept., Desk FV, 350 West 55th St., New York 19, N. Y.**

Rush me **MOTOR'S** work-saving **TROUBLE-SHOOTER**. I will pay postman \$1 on delivery, plus 43c postage and actual Gov't. C.O.D. charges for each copy ordered. Unless completely satisfied, I may return book in 7 days and my money will be promptly refunded.

Name \_\_\_\_\_  
Address \_\_\_\_\_  
City \_\_\_\_\_ Zone \_\_\_\_\_ State \_\_\_\_\_

**SAVE 43c POSTAGE, C.O.D. CHARGES.** Check if you send \$1 with coupon, then we pay shipping charges. Same refund guarantee.



## “My eyes are my trademark!”

When you see Eddie Cantor's famous banjo eyes, you look for comedy, humor, a touch of pathos—a real virtuoso performance.

And when you see a familiar brand name as you shop, you expect an equally outstanding performance—or you don't buy the product again.

That's one big advantage about living in a land where you enjoy free choice among many fine products, each identified by its own brand name.

Leading manufacturers, seeking to win your favor for their brands, take infinite pains and

a great deal of pride in bringing you wonderful products, continuously improved, representing unusual value for your money.

As you leaf through the pages of this magazine, note how many of the products advertised here already have satisfied you. And always *remember* that when you name your brand, you better your brand of living!

### **BRAND NAMES FOUNDATION**

INCORPORATED

A Non-Profit Educational Foundation  
37 West 57th Street, New York 19, New York

# The Most Fascinating Book About the Automobile Ever Printed!

Popular  
Mechanics

## AUTO ALBUM

The Motor Car in Picture  
and Story from  
1769 to 1952



### You'll Find...

The Answers... The Fascinating Stories... in the AUTO ALBUM

Who built the first horseless carriage?

Who obtained the first U.S. patent on an automobile?

Where did the name "automobile" come from?

Are you familiar with the workings of the Stanley Steamer... the "electric"... the famous Ford Model T?

Do you know when the first Indianapolis race was won... by whom... at what speed?

Do you know the story of Henry Ford, Barney Oldfield, Ransom Olds, Walter Chrysler, W. C. Durant and other automotive giants?



Cloth  
Binding

166 Illustrations Including  
94 Old-Time Cars — 22 Auto  
Ads of By-Gone Days!

Here is a book you can't help enjoying and wanting, whether or not you have, or ever will own an automobile. It is the fascinating, thrilling and informative story of the horseless carriage from the first gasoline-propelled buggy to a forecast of the atomic car of the future.

Popular Mechanics AUTO ALBUM by Throm and Crenshaw presents America's first cars and the pioneering men who made them; the scrambled start and the development of the fabulous auto industry; the story of automobile racing; the growth of the Nation's highways. It is a book that just had to be published.

To Read... to Enjoy...  
to Remember!

More than one-half of the book is pictures, most of them action pictures, from photos of old-time cars in operation. Other pictures show race cars from 1911 to 1951; early auto advertising, picturing 22 cars priced from \$275 to \$6000; tri-cycle autos, wind wagons, auto cycles and other automotive oddities. A roll call of horseless carriages is included — the names of more than 2000 cars made in the United States.

Gift Book of the Year

Get the fascinating AUTO ALBUM for yourself today. Send it as a gift to friends and business associates. Order an coupon below. Money refunded if you are not entirely pleased.

Use Coupon to Get AUTO ALBUM

POPULAR MECHANICS PRESS, 200 E. Ontario, Chicago 11

Send at once postpaid — copies of Popular Mechanics AUTO ALBUM at \$3.00 each.  Remittance enclosed.  Send C.O.D. I will pay postman plus charges. I understand books are returnable in 7 days for full refund if I am not pleased.

Name \_\_\_\_\_

Address \_\_\_\_\_

City \_\_\_\_\_ Zone \_\_\_\_\_ State \_\_\_\_\_

# FREE

SEND FOR  
THE

# 1954

## ALLIED

268  
value-packed pages

### TV & RADIO CATALOG

WORLD'S MOST COMPLETE

Save on everything in TV and RADIO



Everything for Experimenters,  
Builders, Amateurs, Servicemen,  
Engineers and Soundmen

Send for ALLIED's big 268-page value-packed buying guide to everything in TV and Radio! Largest selections of custom TV chassis, TV accessories, FM and AM radios, High-Fidelity Sound, Amateur supplies, P.A. Systems, recorders, test instruments, builders' kits, industrial electronic supplies — plus the world's largest stocks of electronic parts, tubes, tools and books. Get everything — get more for your money — send today for your FREE 1954 ALLIED Catalog.

NEW HOME OF ALLIED RADIO



SEND FOR  
FREE CATALOG

ultra modern facilities  
TO SERVE YOU BEST

## ALLIED RADIO

ALLIED RADIO CORP., Dept. 5-8-4  
100 N. Western Ave., Chicago 80, Illinois

Rush FREE 1954 ALLIED 268-Page Catalog

Name \_\_\_\_\_

Address \_\_\_\_\_

City \_\_\_\_\_ Zone \_\_\_\_\_ State \_\_\_\_\_



WORLD'S  
LARGEST  
STOCKS

## You Can Be a Manufacturer of Brikrete



"The World's Most Modern Masonry" is produced in a chain of independently owned local plants. That's why such low prices go along with such high quality without sacrifice of manufacturing profits. Local materials and local labor cut freight and distribution. Brikrete brings a super-masonry down to price levels of frame. Gives owners incentive to buy.

Brikrete has design, size, and color in keeping with the modes of today. Self-contained insulation values—12" long—8" or 4" thick—range of 14 colors. Suited to every kind of construction—residential, commercial, industrial.

Many territories are open for additional local plants. Franchise protection. Equipment available on easy terms, or basic machine can be leased to responsible operators. Write today for interesting Brikrete Book No. 2.

**Brikrete Associates, Inc.**  
4679 Division Avenue, S.  
Grand Rapids 8, Mich.



The World's Most Modern Masonry

## BUILD your own TV Set

YES, actually build a valuable TV Set right at home. At the same time learn all about installing, repairing, servicing—and get ready for a Big-Pay Job in America's fastest-growing, most exciting industry. The CBI TV Train-at-Home Plan is preparing hundreds for bigger pay TODAY—and a brighter Future TOMORROW. No experience needed. We supply easy-to-understand instructions—made clear with hundreds of charts, diagrams, photos—plus TWENTY KITS of Parts, Professional Equipment and Tools. Get a TV Set to ENJOY. Get set to ENJOY a TV Future. Make money in spare time while taking Course. THOUSANDS SUCCEEDING! So can You. Send today for big FREE Book, "You Can Succeed in Television."

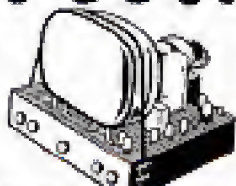

COMMERCIAL TRADES INSTITUTE

Dept. T2-2, 1400 Greenleaf Ave., Chicago 26, Ill.

Say You Saw It in Popular Mechanics

## NEW MIRACLE TUBELESS HEARING AID REVEALED

- Costly B-Battery Eliminated
- All Battery Costs Slashed 80%
- Powered by Three Transistors
- Vacuum Tubes Banished Forever

**FREE BOOK!** Write today for authoritative illustrated book describing this new Atomic Age miracle invention, the Transistor, and what it means to the hard of hearing. No obligation whatsoever! A postcard will do.

**Beltone HEARING AID CO.**  
2900 West 36th Street, Dept. 3242  
Chicago 32, Illinois

## FREE OUTFIT STARTS YOU IN BIG MONEY SHOE BUSINESS!

We furnish everything FREE to set you up in your own profitable full or spare-time shoe business. Just 4 easy sales a day brings up to \$84 a week EXTRA! Repeat orders mean big, steady profits. No experience or investment needed.

You feature over 150 fast-selling styles in dress, sport, work shoes for men, women, including beautiful Nylon mesh shoes with Air Cushion insoles. Also special kinds of shoes for different occupations. Amazing range of sizes, widths. Fit customers stores are unable to take care of. Start now by selling to friends, neighbors and relatives. EVERYONE is your prospect. Just send your name on postcard TODAY for FREE SELLING OUTFIT! Mason Shoe Mfg. Co., Dept. MA-280, Chippewa Falls, Wis.

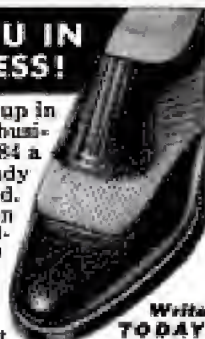

Write TODAY!

## STOP Fires!

in FORESTS, HOMES, OFFICES

25c EACH or 3 for 50c. Postpaid



with CIGARETTE SNUF-ER!

131 Not cut cigarette in 30 seconds! 131 No sparks at all! 131 Snuff out smoke and ashtrays. 141 Single burning match use over 137 Also light chimney without extinguishing.

THOUSANDS IN USE!

**OLEN PRODUCTS, Dept. PM-2**  
Box 757 • Fresno Station • Los Angeles 35, Calif.

## MONEY MEN ALL FREE

THE PLASTEX Industry needs manufacturers on small scale and for big production of Lamp and Clock Stands, Art Goods and Novelties in Plastic and Marble imitation. Experience unnecessary. Top material makes regular top scale sellers. Master moulds furnished for speed production. Small investment brings good returns. We are now placing big Chain Store orders with manufacturers. Ambitious big scale chance for real prosperity. Our free booklet will interest and benefit you.

**PLASTEX INDUSTRIES, Dept. A**  
3400 Third Ave. New York 36, N. Y.

## Handy Mail Order List

Little Library of Useful INFORMATION

5 for \$1.00  
12 for \$2.00  
25¢ Each

- Here at amazingly low cost is the practical help and information you have always wanted. Articles in previous issues of Popular Mechanics have been classified according to subject and are now available in these handy reprint booklets.
- How to Use Measuring Tools—Micrometers, Calipers, etc.—104.
  - Power Drive Saws—74.
  - Drill Presses, Grinders, Etc.—79.
  - Wood, Metal Turning—Lathes—81.
  - Filing Machines, Hack Saw, Cut-off Wheel, Saws—82.
  - Lathe Tools You Can Make—101.
  - Workbenches—Tool Cabinets—47.
  - Spray Painting—94.
  - From Pattern to Casting—91.
  - Tool and Saw Sharpening—92.
  - Sharpening Drills, Wood Bits—93.
  - Successful Wood Turning—92.
  - How to Read Blueprints—71.
  - Metal Turning Lathe Kinks—90.
  - Operating a Metal Lathe—100.
  - Heat Treating, Hardening—102.
  - Working With Glass—103.
  - Serviceing Elec. Motors—72.
  - Electromagnets & Solenoids—44.
  - Transformer Construction—41.
  - The Boy Electrician—43.
  - Soldering and Braiding—17.
  - Arc and Spot Welders—5.
  - Electroplating With Nickel, Chromium, Cadmium, Etc.—80.
  - Flaming Lathes, Wood, etc.—87.
  - Lower Your Fuel Costs—31.
  - Sealing Leaky Basements—48.
  - Fitting Home Game Room—55.
  - Indoor & Outdoor Fireplaces—88.
  - Backyard Gardening—39.
  - Lawn and Garden Novelties—72.
  - Lawn and Garden Furniture—77.
  - Playground Equipment—73.
  - How to Use Your Drill Press—128.
  - Making Serving Trays—83.
  - Knots and Ropework—105.
  - Small Tables—84.
  - Smoking Stands—86.
  - Desk—88.
  - Book Cases—89.
  - Action Toys—85.
  - High Flying Kites—87.
  - Telephones—90.
  - Wool Craft—86.
  - Small Looms—37.
  - Ben Cutting—82.
  - Photo Enlargers—1.
  - Photo Kinks—86.
  - Cleaning Formulas—11.
  - Taniderry—8.
  - Photo Lighting—139.
  - Training Dogs—38.
  - Small Furnaces—34.
  - Working With Plastics—61.
  - Simple Home Improvements—104.
  - Ridding Home of Insect Pests—107.
  - Children's Room Furniture—51.
  - Jigsawed Novelties—87.
  - Doll House & Doll Furniture—100.
  - 25 Shelves You Can Make—84.
  - Novelties Turned on Lathes—82.
  - Inlay Pictures—Marbling—83.
  - Wood, Soap Carving—85.
  - Windmills & Weathercocks—88.
  - Lamps from Wood, Metal—89.
  - Novel Furniture—18.
  - Wood Finishing—40.
  - How to Fix Electrical Appliances—113.
  - Painting Your House—117.
  - Build Your Own Relays—123.
  - Rowboats, Small Dinghy—83.
  - Small Sail Boats—84.
  - Two Outdoor Sunbaths—85.
  - Build Own Garage, Ramps—89.
  - Build Class-E Ice Yacht—22.
  - Auto Kinks, Starters—10.
  - Lawn and Garden Equipment—124.
  - Motor-Driven Midget Cars—84.
  - Map Auto Elect. Troubles—88.
  - Photo Filters and Dryers—28.
  - Photo Darkroom Equipment—80.
  - Trick and Table Top Hoops—87.
  - Home Movie Equipment—110.
  - Poultry Houses—108.
  - Guns and Decays—106.
  - Re-Silvering Mirrors—70.
  - Chemical Experiments—83.
  - Log Cabins, Tourist Houses—14.
  - Using Basic Tools—120.
  - Farm and Garden Tractors—8.
  - Building Extra Attic Rooms—93.
  - Attractive Basement Rooms—84.
  - Senders—80.
  - Home Wiring—89.
  - Hanging Wallpaper—38.
  - Built-in Fixtures—78.
  - Bed Houses—7.
  - Magazine Racks—49.
  - Clock Cases—80.
  - Book Ends—82.
  - Small Tables—84.
  - Smoking Stands—86.
  - Desk—88.
  - Book Cases—89.
  - Action Toys—85.
  - High Flying Kites—87.
  - Telephones—90.
  - Wool Craft—86.
  - Small Looms—37.
  - Ben Cutting—82.
  - Photo Enlargers—1.
  - Photo Kinks—86.
  - Cleaning Formulas—11.
  - Taniderry—8.
  - Photo Lighting—139.
  - Training Dogs—38.
  - Small Furnaces—34.

Check Titles Wanted, Clip, Mail with Remittance to

POPULAR MECHANICS PRESS, Dept. 23, 200 E. Ontario, Chicago 11

# Can A Man My Age Become A Hotel Executive?

**YES!**

"Took the Lewis Course after leaving the Air Force. Now Asst. Hotel Manager."  
—L. M. Benz



The success of Lewis Graduates proves you can qualify for fascinating hotel, motel and club field or apartment house projects. Opportunities everywhere for both young and mature. Previous experience proved unnecessary. Train at home in spare time or through resident classes in Washington. Nationwide Placement Service FREE. Write for FREE book, "Your Big Opportunity."

**YES!**

"Running 'Y' Cafe. Income increased 50%. Thank a Lewis."  
—W. B. Hall

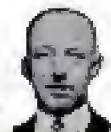

Approved for ALL Veteran Training  
**Lewis Hotel Training School**  
Desk XE-303, Wash. T. D. C. 38th year

**Write Today for FREE BOOK**



## FREE Catalog

Ready February 4

Fully illustrated, 100 pages, showing special fishing tackle, footwear, clothing and one hundred and twenty other leather and canvas specialties of our own manufacture.

**L. L. Bean, Inc.**  
18 Main St., Freeport, Maine  
Mrs. Fishing and  
Camping Specialties

**Say You Saw It in Popular Mechanics**

**PUMP WATER FAST!**

DRAIN WASH TUBS, CELLARS, CISTERNS  
IRRIGATE—FILL TANKS—DRAW WELL WATER

Pumps 2800 GPH, 420 GPH at 75' High or 1600 GPH from 25' well. Sturdy, Rustproof Alloy Metal, Six Blade Impeller. Uses any 1/8 to 1/2 H.P. Motor. Will not leak or clog. Fits any garden hose. Immediate Money Back Guarantee. Send Check, M.O., or C.O.D. **8.95** U.S.

**MOORE MANUFACTURING CO.**  
SWEDSBORO | NEW JERSEY

I SHOW YOU HOW TO

# ① MAKE MONEY AT ONCE

# ② START YOUR OWN BUSINESS

**IN 2 WEEKS—  
AT HOME  
IN SPARE TIME**

## METALIZE BABY SHOES

IF YOU ACT NOW, I will show you how to start earning extra money immediately—in spare time or full time. AND I SHOW YOU HOW to start your own profitable business. With my complete course and easy-to-understand illustrated instructions containing trade secrets of ALL metalizing processes PLUS beautifully processed sample metalized baby shoe AND all my tested and proved methods of operating a successful metalizing business. I show you how to start YOUR OWN profitable, fascinating business right in YOUR OWN HOME. Absolutely no experience needed. For \$10.00 send coupon today for FREE details of my MONEY MAKING PLAN for you and be convinced.

**FREE!**

**MONEY MAKING PLAN**

**Full Details Without Obligation**

**MAIL COUPON TODAY!**

**KIKTAVI CO., Dept. PM-542**  
7217 So. Broadway, Los Angeles 3, Calif.  
Send me FREE details of your MONEY MAKING PLAN, without obligation.

NAME \_\_\_\_\_  
STREET \_\_\_\_\_  
CITY \_\_\_\_\_ ZONE \_\_\_\_\_ STATE \_\_\_\_\_

**DAN LURIE**  
"America's Most Muscular Man"  
—on television's "Big Top"

## FAMOUS DAN LURIE BARBELLS

with 4 courses—low factory prices  
50 lb. set... \$ 8.48 | 150 lb. set... \$20.48  
100 lb. set... 13.98 | 200 lb. set... 25.98

Write for Order by Mail: 50% with order, bal. C.O.D. Free Catalog Extra wts. 13c per lb., F.O.D. plant

**DAN LURIE BARBELL CO.**  
1701-M-2 Pitkin Ave., Dept. 459-B, Brooklyn, N. Y.

# LEARN MEAT CUTTING AT NATIONAL

Pay After Graduation



The steady dependable trade of Meat Cutting taught easily in 8 short weeks. YOU LEARN BY DOING under actual meat market conditions in big modern school at Toledo.

For beginners or men with experience. Get a profitable store of your own. Remember, PEOPLE MUST EAT! Big pay jobs. Free employment help. Thousands of successful graduates.

Buying, cutting, percentage, pricing, advertising, selling, etc. A complete retail meat education. National School established over 30 years. Get National training NOW. Pay your tuition in easy weekly payments

after you graduate. Send coupon for FREE 52 page school catalog — TODAY. G.I. approved.

**National School of Meat Cutting, Inc., Dept. 50-B, Toledo 4, Ohio**

Send me your FREE school catalog on National Training at Toledo in Meat Cutting, Meat Merchandising and Self Service Meats. No obligation. No salesman will call.

Name \_\_\_\_\_ Age \_\_\_\_\_  
Address \_\_\_\_\_  
City \_\_\_\_\_ State \_\_\_\_\_

Approved for training Korean Veterans

POPULAR MECHANICS

# FAMOUS LITTLE LIBRARY OF USEFUL INFORMATION

Complete Set of 126 BOOKS only \$17.95

25 BOOKS	\$3.75
12 BOOKS	\$2.00
5 BOOKS	\$1.00

SINGLE BOOK 25c

Here at amazingly low cost is the practical help and information you have always wanted. Articles in previous issues of Popular Mechanics have been classified according to subject and are now available in these handy reprint booklets.

Check titles wanted, clip ad, mail today.

## HOME WORKSHOP

Power-Driven Saws—74: How to build, Drill Presses, Plans, Grinders—76, Sanders—80; Details on 8 machines, Wood & Metal-Turning Lathes—81, Filing Machine, Hack Saw, Cut-off Wheel, Shaper—82; Full details on these, Metal Lathe Tools—101: How to build, Workbenches and Tool Cabinets—47, Spray Painting—64: Proper methods, From Pattern to Casting—91: How castings are made in sand molds, How to Use a Circular Saw—135, Jigsaw Techniques—136: How to Use, Bandsaw Know-How—137: Techniques,

Tool and Saw Sharpening—92: Tricks and hints,

Technique of Using Drills and Wood Bits—90, Successful Wood Turning—92, How to Read Blueprints—71: Tells you how, Metal Turning Plans—99, Operating a Metal Turning Lathe—100, Heat Treating and Case Hardening—109, Working with Glass—103: Cutting, etc., Using Basic Tools—120: Tips and hints,

## WELDING • SOLDERING

Rewinding & Servicing Electrical Motors—75: Repairing and rewinding motors, Electrical Appliances, How to Fix—111, Electromagnets & Solenoids—44, Transformer Construction—41: Directions, The Boy Electrician—43: Five projects, Soldering & Brazing—17: Tells how to, Arc & Spot Welders—8: How to use & build, Build Your Own Relays—123: Instructions, Home Burglar Alarms, Secret Locks and Time-Setting Systems—126, Welding with Arc and Gas—134: Tips,

## AUTOMOBILE BOOKS

House Trailers—121: Build it yourself, Automobile Kinks and Shortcuts—10, Building Trailers—Small Teardrop and Utility—27: Can be built in your spare time, Motor-Driven Midget Car & Scooter—34, Curing Auto Electrical Troubles—25,

## BUILD A BOAT

14 Ft. Outboard Runabout—2: How to build, Rowboat, Bicycle Boat, Small Dinghy—83, Small Sail Boats—84: For young sailors, Two Outboard Runabouts—85: 14 ft. & 12 ft., Build Your Own Canoe, Kayak, Surfboard—30: Complete building details, Fast Class-E Ice Yacht—32: Build your own,

## GARDENING HELPS

Lawn and Garden Equipment—124, Handy Farm Implements—114: How to build, Tractor Attachments—116, Backyard Gardening—39: Helpful hints, Lawn & Garden Novelties—72: Easy to build, Trellises, Pergolas, Fences—76, Lawn & Garden Furniture—77, Colored Concrete Garden Furniture—6, Farm & Garden Tractors—8: How to build,

## PHOTOGRAPHY

Home Movie Equipment—118: How to use, Photo Lighting—119: Helpful information, Photo Relaters—11: Complete plans, Photo Printers & Dryer—28: Describes three, Photo Darkroom Equipment—26, Picture Projector, Trick & Table Top Photography—67: Tips on how to make, Photo Kinks—98: Money-saving ideas,

## FURNITURE MAKING

Furniture Upholstery and Repair—122, Rustic Furniture—19: How to build, Children's Room Furniture—51, Book Ends—52: Good selection from 10 designs, Small Tables—84: Interesting styles, Desks—53: Many varied designs, Smoking Stands—55: Seven designs given, Plain & Novelty Wood Finishing—40, Book Cases—59: Eight designs, Magazine Racks—49: Ten attractive racks, Clock Cases—50: Several types, Serving Trays for Every Occasion—53,

## MISCELLANEOUS

Cleaning Formulas—11: Make your own, Re-Silvering Mirrors—70: How to do it, How to Build a Concrete Block Machine—110: Make your own block machine, It's Easy to Tie Knots—105, Chemical Experiments—93: Several, Taxidermy—9: How to mount small animals, Log Cabins and Tourist Cottages—14, Magic for Everybody—29: Simple tricks, Training Small Animals—33: How to trap, Training Your Dog—35: Tricks and obedience, Small Furnaces—36: For melting copper, etc., Electroplating with Copper, Nickel, Chromium, Lead, Zinc, Cadmium—86, Plating Non-Metallic Objects — Plating with Gold, Silver, Alloys—87, Telescopes—20: Design and construction, Poultry Houses—108: How to build, Guns & Drays—109: Clean guns, make drays, For Better Business—130: Timely tips, For Better Business—132: Saves time, For Better Business—133: For smooth operation,

## HOME IMPROVEMENTS

Painting Your House Inside and Out—117, Simple Home Improvements—104: Save money, Building Extra Rooms in Your Attic—23: Add to the value of your home, Basement Playrooms—24: Build an attractive playroom in your basement, House Wiring—89: How to do it, Curing Leaky Basements—45, Fitting Home Game Room—55, Built-in Flatware—78: Several, Lower Your Fuel Cost—31: Practical kinks that will save you hundreds of dollars, Hanging Wallpaper—38: Hints and tricks, Ridding the Home of Insect Pests—107, Constructing Indoor & Outdoor Fireplaces—88: Details on stone fireplaces,

## CRAFTWORK • HOBBIES

Games and Puzzles—121: Have fun at home, Model Planes You Can Build—129: Several, Fun With Your Model Railroad—127, How to Make Novelty Jewelry—126, Working with Plastics—61: Novelties, etc., 25 Shelves You Can Make—64: Wall shelves, etc., Novelties Turned on Lathes—62: Dishes, etc., Projects in Plastics—113: How to use, Inlay Pictures—Veneering—83, Whittling and Wood Carving—65: Methods, Action Toys—66: 21 easy-to-make toys, Marionettes—113: How to make and use, High Flying Kites—67: How to build, Windmills & Weathervanes—68, Lamps in Wood, Metal, Plastic—69: Several, Bows and Crossbows—115: How to make, Playground Equipment—73: 6 projects, Metal Craft—20: Simple instructions, Weaving and Rensing—37: Full details, Gem Cutting—42: How to cut and polish,

## USING TOOLS

How to Use Your Drill Press—125, Correct Measurements—106: How to obtain,

USE THIS HANDY ORDER COUPON NOW!

POPULAR MECHANICS PRESS  
200 E. Ontario St., Chicago 11, Ill.

24 Books	12 Books	5 Books	1 Book
\$3.75	\$2.00	\$1.00	25c

I enclose \$\_\_\_\_\_ (U.S. currency may be mailed if carefully wrapped) for "Little Library" booklets numbers:

NAME \_\_\_\_\_

ADDRESS \_\_\_\_\_

CITY \_\_\_\_\_ ZONE \_\_\_\_\_ STATE \_\_\_\_\_



Examine  
**FREE!**



# HOW TO BECOME A SUCCESSFUL MANUFACTURER'S REPRESENTATIVE

**N**OW . . . for the salesman who wants to start and operate a business of his own in the lucrative sales agency field . . . here's the first book ever devoted exclusively to showing ambitious salesmen how they can earn \$10,000, \$15,000, \$25,000, or more a year through representative selling.

It shows you how you can start your own business right now . . . with no other investment but your own sales experience! It shows you, right DOWN to the minutest detail, everything you need to know to make a success out of being a manufacturer's representative:

- 4 quick ways to get yourself known in the field.
- 14 "bargaining position" tips that win more accounts.
- Fool-proof ways to test marketable lines.
- How to give all your principals ample representation.
- How to switch a buyer's interest from line to line.
- 4 sure-fire compensation plans.
- Tested ways to establish compensation plans.
- 11 elements of a protective contract.
- How to eliminate excessive distribution costs.
- How to step up sales volume without expanding.
- How to use direct-mail advertising to build your business.
- 15 sales techniques slanted toward the manufacturers' representative.
- The 20 best areas for representative selling.

- How to set up the physical structure of your business.
- 10 Agencies to help you get started.
- How to get non-competitive lines with a profit potential.
- 7 ways to locate manufacturers who need representation.
- Expert tips on eliminating costly mistakes at the outset.
- 9 things to look for before accepting an account.
- 3 types of contracts that protect you.
- Advantages and disadvantages of various lines.
- How to build loyal customer following for volume sales.
- How to set up territories that give more "sales mileage."

**10-DAY  
FREE  
TRIAL!**

**MAIL  
COUPON  
TODAY**

**PRENTICE-HALL, INC., Dept. M-PM-234**  
70 Fifth Avenue, New York 11, N. Y.

Please send me a **FREE EXAMINATION COPY** of "How to Become a Successful Manufacturer's Representative." Within 10 days I will either send you \$4.00 plus postage, or return the book and owe nothing.

Name \_\_\_\_\_  
Address \_\_\_\_\_  
City \_\_\_\_\_ Zone \_\_\_\_\_ State \_\_\_\_\_

Say You Saw It in **POPULAR MECHANICS**

## 60 POWER TELESCOPE \$3.98

**VARIABLE EYEPIECE 20x-40x-60x — BRASS BOUND NEW!** Three telescopes in one. 3 different magnifications. 20 power for ultra-bright images with 40 and 60 power for extra long range. Guaranteed to bring distant objects, people, sports events, ships, moon, stars, etc. 30 times as clear.

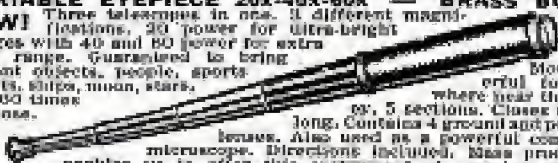

Most powerful for any-where near the moon. 60x. 5 sections. Close to 1 ft. long. Contains 4 ground and polished lenses. Also used as a powerful compound microscope. Directions included. Mass production enables us to offer this instrument at amazing price of \$3.98 complete. Money back guarantee. We pay postage. Get yours now.

Criterion Co., 331 Church St., Hartford, Conn., Dept. PMB 20

## Print Your Own



Cards, Stationery, Advertising, labels, circulars, photo and movie titles, church work, tags, etc. Save money. Sold direct from factory only. Raised printing like engraving, too. **Print for Others, Good Profit.** Have a home print shop. Easy sales supplied. Pays for itself in a short time. Write for free catalog of outfits and all details.

KELSEY PRESSES, N-37 MERIDEN, CONN.

**MAIL THIS COUPON TODAY! Free Facts On How You Can Make \$10,000 a Year!**

### RED COMET, INC.

385-N R. C. Bldg., Littleton, Colorado  
Send me at once complete information about Red Comet Automatic—the fire extinguisher that stops fire automatically—without human aid. Needed now by every home, farm, business. Tell me how I can make \$10,000—and more—a year, full time . . . \$75 to \$100 a week part time. I understand you will furnish me **FREE** professional Sales Kit with actual sample units, sales manual, other helpful literature to make me a Red Comet Dealer.

NAME \_\_\_\_\_ STATE \_\_\_\_\_  
ADDRESS \_\_\_\_\_ CITY \_\_\_\_\_

Advised Post, Collier's, Business Week

## GROW Living MIDGET TREES!

**EARN \$1000 PER HOUR!**

- AT HOME
- IN SPARE TIME
- NO EXPERIENCE NEEDED



It's new! Amazing! At last, the secret of growing miniature (MINGI) trees can be yours. **FULL GROWTH**, dwarf trees—only a few inches high. Beautiful miniature fir, orange, oak, Chinese elm, peach, pine, cypress—any kind! **ALL BLOOM** and even **BEAR FRUIT**. All perfect healthy specimens—but miniature in size! Make costly home decorations and expensive centerpieces. **ISOLD FOR OVER \$1,500 EACH!** Big demand. Costs only pennies—takes only minutes per week. **IT'S EASY!** Fun! A new fascinating hobby—a new fabulous \$\$\$ business. Send for free secret plan details and real seed.

### HELP US FILL HUGE DEMAND!

These trees are being demanded by **STORES CLUBS • HOTELS • FLORISTS • HOUSEWIVES • INTERIOR DECORATORS • COLLECTORS • HOBBYISTS — A Big Money Opportunity FOR YOU.**

**FREE! GENUINE SEED AND PLAN!**



**NATIONAL NURSERY GARDENS, Dept. M2**  
8463 South Van Ness  
Inglewood 4, Calif.  
Rush me **FREE** plan and seed **IMMEDIATELY!**

Name \_\_\_\_\_  
Address \_\_\_\_\_ Zone \_\_\_\_\_  
City \_\_\_\_\_ State \_\_\_\_\_

# Announcing the NEW...POPULAR MECHANICS MAGAZINE LIBRARY FILE



Check these Outstanding Features

- 1 Convenient size, measures 8 3/4" wide, 3 3/4" thick x 10" high. Ideal for tabletop, shelf or bookcase storage.
- 2 Special Reference Index Form, printed on back, records exact location of selected articles, diagrams and other information.
- 3 Date Label Stickers—enough to index ten years issues, furnished FREE.

**NEW! NOVEL! INEXPENSIVE!**  
Never before so much convenience and utility at such a low price. So act now. Place your order today!

## INGENIOUS CUSTOM-BUILT STORAGE FILE A Sensational Popular Mechanics Value Scoop!

Now you can preserve every issue of Popular Mechanics Magazine in orderly, chronological sequence... indexed and ready for instant reference! Made of high quality kraft fibre board, printed in rich colors and constructed to look like an attractively bound book, Popular Mechanics Magazine Library Files enhance the reference value and double the usefulness of your collection of Popular Mechanics Magazines.

Serviceable, convenient, handsome in appearance, Popular Mechanics Magazine Library Files make every volume and article instantly accessible. No more hunting for the issue or special data you want. No misplaced copies. A "must" for every reader of Popular Mechanics. Order now for immediate delivery. Use the handy coupon below.

**PER SET OF 2**  
(Set holds 12 issues)

Only

**70**¢

POSTAGE PAID

5 SETS **\$3.10**  
ONLY

10 SETS **\$6.00**  
ONLY

POSTPAID

Best of all, production economies by the distributor service organization appointed by us to serve your needs—plus our large volume purchases—makes the phenomenally low cost of the Libraries possible.

### USE THIS COUPON...Mail Today

POPULAR MECHANICS MAGAZINE, Dept. PL  
200 East Ontario Street, Chicago 11, Illinois

P-2-54

Please rush PREPAID \_\_\_\_\_ sets Popular Mechanics Magazine Library Files.  
(QUANTITY)

Remittance for \$ \_\_\_\_\_ is enclosed.  
(AMOUNT)

PRICES — 1 set (2 files) Holds 1 yr's issues . . . . . only \$ .70  
5 sets (10 files) Holds 5 yr's issues . . . . . only \$3.10  
10 sets (20 files) Holds 10 yr's issues . . . . . only \$6.00

Includes Prepaid Parcel Post anywhere in U.S. and Possessions

Name \_\_\_\_\_

Address \_\_\_\_\_

City \_\_\_\_\_ Zone \_\_\_\_\_ State \_\_\_\_\_

# EARN BIG MONEY SOONER THROUGH SHEER WORD POWER!



No doubt about it, many a man has succeeded through sheer word power, where more able men have failed without it. Don't risk this handicap! Get the advantages of word power this easy way.

## DON'T BE A LOSER

You could know more than any man in the world, yet without the words to tell others—without the power to convince them—you suffer from a real, if invisible, handicap.

Your boss will never know you're the best man for the big job unless you can convince him. Friends and acquaintances will never know how interesting you can be unless you can open your mind to them through words as well as deeds. The fact is this: people are not mind readers, and unless you have the word power to "get across," you may stand to lose out! Yet you need not.

## THE SENSIBLE WAY TO WORD POWER AND SUCCESS

There is a sure way for you to achieve the mastery of words and facts you need for success.

It is through the aid of *Webster's New International Dictionary, Second Edition*—"the Supreme Authority" wherever English is spoken. A mere ten minutes a day with this great book will help you, as it has already helped thousands before you, to speak more effectively, write more accurately, read with more understanding . . . and attain success in your job **FASTER!**

## EVERY SUBJECT IN THE RANGE OF MAN'S KNOWLEDGE

This big Merriam-Webster in a single volume will supply you with authentic fundamental information relating to every subject in the range of man's knowledge, in many technical and cultural subjects the near equivalent of a textbook or college course. With the background it gives you, you'll never be at a loss in discussing history, science, and language, for business or for pleasure. With it you can often enlighten your boss, impress your friends—and tear down barriers to business and social advancement, through knowledge and *sheer word power!*



600,000 Entries. 3,350 Pages. 12,000 Terms Illustrated. Magnificent Color Plates. Biographical and Geographical Sections. Equivalent in Type Matter to an 18-Volume Encyclopedia.

## THINK WHAT IT CAN MEAN TO YOU!

This *Webster's New International Dictionary, Second Edition*, is dollar-for-dollar the greatest value in book form. It is in constant use in libraries and universities and in important business offices throughout the country. When you consider the advantages of owning it yourself—when you consider what it may do for you, on your job and among your friends—you cannot afford not to own it!

Look for the trade-mark and insist on a genuine Merriam-Webster. At book, department, and stationery stores. \$35 to \$49.50.

## SEND FOR TWO FREE BOOKLETS!



"Interesting Origins of English Words"  
"The Merriam-Webster—What It Will Do For You!"

G. & C. Merriam Co., Publishers, M-1  
Springfield 2, Massachusetts

Please send me, free, your two exciting illustrated booklets: "Interesting Origins of English Words"; and "The Merriam-Webster—What It Will Do for You," which gives details about the dictionary and tells how it can help me be a success.

Name.....

Address.....

City.....(Zone).....State.....

*A Merriam-Webster*

REG. U. S. PAT. OFF.

# NEW INVENTION REPLATES by ELECTROPLATING RESTORES HOME, AUTO METALS CHROME-SILVER-GOLD!

NEW BRILLIANCE WITH SAME PROCESS AS PROFESSIONAL PLATERS

## SILVER-CHROME-GOLD



REPLATED, Quickly, Easily Now—with an amazing new invention, APPL-I-COTE®! you plate hundreds of items, using the mild, safe current of 2 flashlight batteries in its handle. All YOU DO is simply attach disk on Applicator to metal, dip brush into solution—and plate as you brush. It's Easy, Quick, Genuine plating.

RESTORES METALS LIKE NEW Replates Silver, Chrome, Nickel, Steel, Gold and Brass—all worn Spots, Stains, "Blistered," Silverware, Trays, Teapots, Bells of Hardware and other items can look like new again with this exclusive Electroplating process. Restores all your valuable Gold jewelry with amazing APPL-I-COTE®. The plating you apply becomes an indestructible part of the metal itself!



QUICKLY BUILDS-UP A THICK NEW PLATING WITH EACH APPLICATION.



- COMPLETE PLATING KITS:  
**MET-L-COTE:** For Chrome & other white metals... **\$3.95**  
**SILV-R-COTE:** For Silver—combination set of Met-L-Cote & Silv-R-Cote... **\$5.95**  
**GOLD-COTE:** For Gold Plating... **\$5.95**



BRILLIANT AUTO TRIM — You'll be mighty proud of the dazzling new finish on your car's bumpers and trim after finishing with MET-L-COTE. And remember, each time you electroplate with the APPL-I-COTE®, you build up a lasting layer of sealing that tremendously lengthens the life of original trim.

MET-L-COTE is constantly used in leading hospitals, and in doctors and dentists offices to Replate surgical instruments—Also in hotels and restaurants to RESTORE cutlery.

**CASH REFUND IF NOT COMPLETELY SATISFIED**

EMPIRE MERCHANDISING CO., Dept. J-2  
 28th E. First St., Mt. Vernon, N. Y.

Please rush the Complete Plating Kits including Solution, New Packet Applicator & full complete instructions I have checked below. I enclose full price, send postpaid, or send C.O.D. plus postage.

MET-L-COTE—\$3.95     SILV-R-COTE—\$5.95  
 Combination MET-L-COTE & SILV-R-COTE—\$9.95  
 GOLD-COTE with Gold Applicator—\$8.95

NAME \_\_\_\_\_  
 ADDRESS \_\_\_\_\_  
 CITY \_\_\_\_\_ STATE \_\_\_\_\_



A THICKER PLATING WITH EACH COAT!

MET-L-COTE—Replates, Restores CHROME, NICKEL, BRASS, COPPER, STEEL, IRON or BRONZE.

SILV-R-COTE—Replates Silver with genuine Sterling.  
 GOLD-COTE—Replates Gold with 24 Karat gold plate. Restores original luster to worn or tarnished valuable jewelry and other Gold items.

**MAKE MONEY AT HOME REPLATE JEWELRY, SILVER, CHROME. EASY SPARE-TIME MONEY.**

**RESTORE YOUR TREASURES—MAKE THEM VALUABLE AGAIN**

## Say You Saw It in Popular Mechanics

start a big profit business with a small investment  
**EARN UP TO \$200 a DAY**

### Manufacturing Exciting New RAINBOW ROCK

Concrete Slump Brick in your back yard

Earn big building boom profits with Rainbow Rock, the colorful new building brick that's taking the country by storm. Sell all you can make to contractors, builders, building supply houses. RAINBOW ROCK CUTS LABOR COSTS BY 1/3! Amazing low cost machine makes modern slump brick 24" long 13 times the length of ordinary bricks in a variety of widths and pastel colors . . . up to 1500 bricks a day! NEEDS NO SPECIAL SKILL. Operates indoors or out. Full instructions and valuable mixing formulas supplied. YOU CAN START EARNING BIG MONEY NOW. PAY AS YOU PROFIT! A limited number of machines available on easy payment terms. NOW is the time to start. Write today for free literature and full information.



STEEL PIER SENSATION location RAINBOW ROCK fireplace wall in living room of the "Home of the Century" in Atlantic City, N. J.'s Steel Pier... obtained by over 500,000 Summer, 1953 visitors as the most beautiful they'd ever seen! Endorsed by the Pier's former architect, William F. & Koelsch.



Make beautiful, decorative fences, garden walls, garages, outside walls, room separators, etc.

GENERAL ENGINES CO., INC.  
 Dept. MR-24—307 Hunter Street  
 Gloucester, N.J. • Gloucester 6-1337

## HE-MAN VOICE!

STRENGTHEN your voice this tested scientific way. Yes—you may now be able to improve the POWER of your speaking and singing voice . . . in the privacy of your own room! Self-training lessons, mostly silent. No music required.



**FREE BOOK** Write TODAY for Eugene Foughtinger's great booklet "How to Develop a Successful Voice." It's absolutely FREE! You must send your age. Booklet mailed postpaid in plain wrapper. No salesman will call. Send your name and age RIGHT NOW! Perfect Voice Institute, 210 S. Clinton St., Studio BW-2, Chicago 6, Ill.

## TAKE YOUR SHORT CUT TO HIGH-PAY JOBS IN Television

No experience necessary . . . you are ready to train as you are! All professional tools and equipment are furnished, COMPLETE. Train for success as a TV technician in your spare time AT HOME . . . EARN WHILE YOU LEARN! Get an additional 80 hours laboratory training without extra charge. Learn the latest, including COLOR TV! Placement Service and Business Plan available. Write for book of OPPORTUNITIES, FREE!

UNITED TELEVISION LABORATORIES, Dept. M54F  
 15th and MAIN    LOUISVILLE 3, KENTUCKY

## REVERSIBLE AUTO SEAT COVERS

\$298

Made of FLEXON Plastic. Colorful SHAKE AND ZERR® DESIGN And EOPARD-GOMIDE DESIGN. Can Be Used On Either Side. Water And Stainproof. Tailored With Side Grip Panels For Tight Fit. Sewn With NYLON Thread For Long Wear. Simple To Install. Dress Up Your Car With These Expensive Looking Covers!

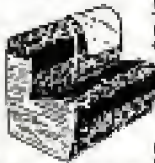

**10 DAY MONEY BACK GUARANTEE**

ORDER FROM MFR. AND SAVE

Choice Of SPLIT Or SOLID Front Seat Only \$2.98. Complete Set For Both Front & REAR ONLY \$6.00.

Specify Design Wanted. Make Of Car And Seat Style. Enclose Payment And Save Postage Or Sent C.O.D.  
 MARDO SALES CORP., Dept. 5-440  
 480 Lexington Ave., New York 17, N. Y.

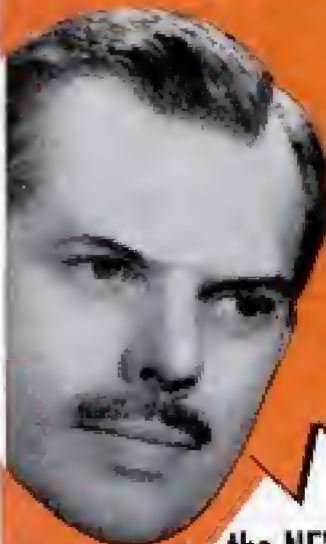

H.E.L.S. IRWIN  
— DIRECTOR OF INSTRUCTION

**MEN-WOMEN!**

**BUILD A BIG PROFIT HOME BUSINESS...**



with **NEW**

# Suede Paint!

SILVERWARE CABINETS

the **NEW WONDER FINISH** that **COVERS EVERYTHING**

... Plastic, Fabric, Metal, Plaster, Wood, Rubber ... any Surface!

**MAKE \$500 to \$1000 PER HOUR and more!**

**SECRETS OF NEW INDUSTRY NOW YOURS**

At last, secrets of this amazing miracle finish can be yours! Huge profits waiting to be tapped in tremendous new field. Flok-Kraft gives a velvety, luxurious surface to radios, lamps, toys, signs, store displays, figurines, auto dash boards — a thousand and one items to be seen on every hand easily and quickly beautified, enriched, increased in value with Flok-Kraft. Make old objects beautiful — saleable, make new things worth much more with this soft, rich covering that can be applied to any surface, even if old or worn.

**BIG PROFITS RIGHT AWAY—LEARN IN FEW HOURS—** Make to \$5.00 — yes! even \$10.00 and more per hour. Fully detailed Flok-Kraft instructions—complete and easy to understand—every point explained—shows you how to start on the road to big money, full or spare time.

**WE FURNISH EVERYTHING YOU NEED TO START—** You also get complete Flok-Kraft kit of materials and equipment that enables you to start at once. Add to your income from your regular job or begin to build a successful business of your own and do it all, right in a corner of your basement, garage, service porch, kitchen or living-room.

**GRASP THIS LIFETIME OPPORTUNITY TODAY** — I'll arrange to send you the complete outfit—everything you need to start—for leisurely, no-risk examination right in your own home. You owe it to yourself to investigate. Fill out and mail the coupon below for **FREE** details, Sample, Plan, etc. Do it today! Everything I send you now is **FREE** of charge and postpaid. Air-mail is faster.

## Read What Others Say About Flok-Kraft Suede Paint...

"Received the Flok-Kraft outfit and everyone that saw it is very enthused. I only had it about thirty minutes, and got an order for a hundred dollar job." Mr. C. H. Maryland.

"Got \$52.50 for those 7 trunk interiors for about 4 hours work. \$7.50 per trunk." J. O., Mo.

"... I have received my order of Flok and Adhesives and believe me, I'm very pleased and happy as I've made myself MORE than the rest of my supplies already, and I've still got more jobs to do." Cpl. G. W., S. Carolina

"... pleased with your course and I'm being swamped with work to do." W. F.,

## Yours to Examine Without Risk

Examine in your own home — then decide. The complete instructions, the full starting kit of materials and equipment plus full details on how you may open your own business — spare or full time — **EVERYTHING** will be sent to **EXAMINE AT OUR RISK.**

## FLOK-KRAFT IN INDUSTRY

This amazing miracle finish is of inestimable value for use on hundreds of manufactured products. Flok-Kraft offers you a way to big, extra money, assisting manufacturers in many lines as well as filling a big demand among home owners.

**FREE!**  
Booklet  
Sample  
Plan!



**SEND NO MONEY—Just Name and Address**

COAST INDUSTRIES, Dept. 22  
1004 S. Los Angeles St., Los Angeles 15, California  
Please rush me **FREE** details, sample, etc. I understand that everything you send is free and that I'll be under no obligation now or ever.

NAME \_\_\_\_\_  
STREET \_\_\_\_\_  
CITY \_\_\_\_\_ STATE \_\_\_\_\_

**Coast Industries** Dept. 22 1006 S. Los Angeles St. Los Angeles, California

Let us show you, **IN ONE WEEK**, how you can

# MAKE MORE MONEY this proven way

In just one week, you can make a startling discovery that may mean THOUSANDS OF DOLLARS of increased income to you for the rest of your life! A remarkable new book, "HOW TO RAISE YOUR OWN SALARY" shows you a step-by-step procedure by which you can definitely multiply your earning power!

Let us send you this new book on **FREE TRIAL FOR ONE WEEK**. See for yourself how its 17 basic, proven principles can be applied to help YOU make more money. Just mail coupon for free-trial copy.

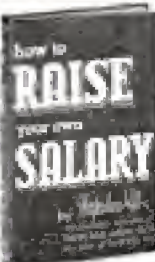

## FREE TRIAL COUPON — MAIL TODAY

Napoleon Hill Associates, Dept. M-3  
A division of W. Clement Stone Enterprises  
3316 Sheidan Road, Chicago 40, Illinois

Without obligation, please send me for **ONE WEEK'S FREE TRIAL** a copy of "HOW TO RAISE YOUR OWN SALARY." In one week, if I decide to keep this book, I will send you only \$3.95 plus postage in full payment. Or I will send the book back to you and owe nothing.

NAME \_\_\_\_\_

ADDRESS \_\_\_\_\_

CITY \_\_\_\_\_ STATE \_\_\_\_\_

**SAVE POSTAGE.** Send \$3.95 with this coupon, and we will pay delivery charges. Same return privileges: your money back if not completely satisfied. We will also send you a personally autographed copy of Napoleon Hill's famous **DAILY CREED**, suitable for framing.



**SEND NO MONEY**  
• **MORE THAN 4000 PAGES**  
• **2750 PICTURES**

## 9 BIG COMPLETE BOOKS BUILDING, ESTIMATING, CONTRACTING

Examine this Up-to-Date Edition for 10 days. See how these nine books supply easily understood training that will help you to get a better job and make more money, or start a profitable business for yourself. Think what a BIG help it will be to have them handy for use in solving all sorts of building problems.

Learn to draw plans, estimate, do all-new construction and modern remodeling to meet fast growing demand. More than 4000 pages of practical, pay-raising information with 2750 helpful illustrations, on such subjects as blueprint reading, concrete forms, masonry, carpentry, steel square, electrical wiring, plumbing, heating, painting, and hundreds more.

In our more than 30 years we have never offered more complete building information. Send the coupon **TODAY**.

(A year's consulting privileges with our engineers now given with these books without extra cost.)

**AMERICAN TECHNICAL SOCIETY—Publishers Since 1898**  
Dept. G-219, Drexel Ave. at 58th St., Chicago 37, Ill.

I would like to examine your 9-Volume Set of Building, Estimating, Contracting Books. I will pay the delivery charges only. But if I choose I may return them express collect. If after 10 days' use I prefer to keep them, I will send you \$3 plus postage and pay the balance at the rate of only \$4 a month until \$34.80 has been paid.

Name \_\_\_\_\_

Address \_\_\_\_\_

City \_\_\_\_\_ State \_\_\_\_\_

Please attach letter giving employer's name and address (if self-employed give business man's name as reference). Men in service please give home address.

## FULLY GUARANTEED TIRES COST LESS!

**SPECIAL! DEDUCT 10% ON 4 OR MORE TIRES!**  
Nationally famous **FIRESTONE**, **GOODRICH**, **U. S. ROYAL**, **GOODYEAR** and other makes. Every tire selected and inspected for your safety.  
**FREE TUBE ON REQUEST WITH PASSENGER TIRES** **WHITE WALLS OR SNOW TIRES \$1 EXTRA**

HIGH GRADE TIRES GUARANTEED 12 MONTHS			
600x16	4.14	700x16	5.14
650x16	4.34	870x15	4.74
680x15	4.34	850x20	7.84
700x15	4.64	700x20R	8.54
750x20	10.94	825x20	14.34
900x20	13.34	1000x20	14.14
1100x20	18.14		

AAA PREMIUM GRADE GUARANTEED 18 MONTHS			
550x16	0.48	700x15	5.98
600x16	5.28	700x16	6.78
600x16(0)	5.88	700x16(0)	7.98
640x16	5.88	750x16(0)	8.98
650x16	6.78	800x15	6.98
650x16(0)	6.98	825x15	7.48
650x15	8.98	710x15	6.09
670x16	8.18	550x16	5.98

**MILITARY SPECIAL AA Guaranteed 12 Months—**  

900x16	10.88	1000x20	13.88
750x20	10.88	1100x20	21.88

**AAA GUARANTEED 18 MONTHS**  

900x16	14.98	750x20	10.48
--------	-------	--------	-------

**NEW TREAD GUAR.**  

800x16	24 Mos.	5.98
600x16(0)		9.98
700x16(0)		15.98
750x20(0)		24.98

Largest stock of used tires in the East. Thousands of satisfied customers. Write for Free Catalogue. **MONEY ORDER OR CHECK** WITH ORDER. **NO C.O.D.'s**  
**PYRAMID TIRE CO.**  
1333-35 North 5th St. Dept. M., Phila. 22, Pa.

## MEN AND WOMEN TRAINED AT HOME FOR PROSPEROUS BUSINESS IN UPHOLSTERING

Tools, Supplies, everything necessary to get started sent. Illustrated training shows how — progress rapidly. No previous experience necessary. Make over old furniture, sell for many times cost to you. Establish full or part time money making business. Free booklet explains plan. Send name, address to

**COMMERCIAL TRADES INSTITUTE**  
1400 GREENLEAF, DEPT. U3-2, CHICAGO 26, ILL.

## Say You Saw It in Popular Mechanics

### LOCKSMITHING & Key Making

**PRACTICAL UP-TO-DATE COURSE—ONLY \$4.95**  
Easy-to-learn modern information for self-instruction. How to work on locks, de-code, make masterkeys, repair, install, service etc. For every handyman, home owner, carpenter, mechanic, service station operator, (if-it-ain't-broke, hardware dealer, gunsmith, 50 main illustrated lessons. **FULL PRICE ONLY \$4.95. SEND NO MONEY.** Just pay postman plus C.O.D. postage. Or send \$4.95 with order. We'll ship postpaid. Satisfaction guaranteed or refund.  
**NELSON-HALL CO., 210 S. Clinton St., Dept. BW-2, Chicago 5, Ill.**

### PORTABLE GARAGE

**\$6.75 Plastic Vinyl**  
**USE IT ANYWHERE**  

- Folds compactly • Keeps rain, snow, dust, and air. 50% of steel
- Protects your car's finish
- Durably constructed of vinyl plastic
- Springlike elasticized bottom, holds securely in all kinds of weather
- Fits all makes • Direct from manufacturer
- Enclose check or money order for \$6.75, plus 25c postage or sent C.O.D., 10-Day Money Back Guarantee.

**MARDO SALES CORP.**  
480 LEXINGTON AVE., DEPT. G-1401, NEW YORK 17, N. Y.

## NEW! POLARVISION SAFETY LIGHT



A revolutionary new light discovery recently released for civilian use.  
**STOP HEADLIGHT GLARE**  
**FOR SAFETY AND COMFORTABLE DRIVING**  
 The Amazing "Eggon Glass Lens" is an integral part of the Polarvision Light. It produces a Black Light barely visible to the eyes which counteracts unshielded headlights, street lights, etc. without interfering with your visibility. Easy to install above windshield—beautiful accessory. Light enclosed in high grade chrome holder. Works off car's central lighting circuit. Limited Supply. Complete **\$6.95**  
 Send cash, check, or money order. **Guaranteed**  
 Electronic Developments, Dept. BP-2  
 10418 Venice Blvd., Culver City, Calif.



# Be a **FLORIST**

Thousands of opportunities. N. L. I. graduates are employed from coast to coast. Learn quickly & easily at home. Flower arrangement included to enable you to make sprays, wreaths, corsages, etc. and make big profits from cut flowers.

## YOUR OWN BUSINESS

You can start small and be successful. Many operate profitable business from own home. Professional material supplied with latest up to date training. Write today for FREE Book.

**FLORAL DIVISION**  
**NATIONAL LANDSCAPE INSTITUTE**

Dept. FF-2, 310 So. Robertson Blvd., Los Angeles 48, Calif

Write Today!



# Bar Bells

Buy Direct From Factory **\$8.95** up  
Write for free booklet and price list.

**INDEPENDENT IRON WORKS**  
2416 East 23rd Street, Dept. B  
Los Angeles 58, Calif.



## FREE New Valuable Catalog for **STAMP** Collectors

Just published by the world's largest stamp firm. Hundreds of illustrations. Lists UNITED STATES stamps (postage and airmail issues complete); big values in U. S. & foreign packets; amazing clearance sale bargains; complete stamp kits; special offers; valuable information, etc. Approvals included. H. E. HARRIS & CO., 154-B Transit Bldg., Boston 17, Mass.

make it with \$4 ..

worth of sand and cement

SELL IT FOR **\$90**

manufacture much-wanted concrete outdoor fireplaces in your yard or basement-exclusive franchise



\$4 worth of sand & cement & only \$12.50 worth of iron-work produced this beautiful fireplace!  
Makes sold for \$129.00!

### your own business at home

No experience needed. Exclusive Molds and Process available only to franchised dealers. We supply full instructions and equipment, 2 days free instruction. Your franchise fully protected. Two men can make 5 fireplaces daily. You can sell all you produce . . . for \$90 to \$180! We help you get started.

### here are your customers!

Homeowners — for barbecues, picnics and parties; state parks, amusement parks, furniture stores, department stores, building contractors, remodelers. Your equipment makes 7 different styles, each beautiful and useful. Every sale is another recommendation. Mr. T., of Phila., reports selling 250 in his first 4 months. His customers included 3 leading department stores.

First 2 Sales Can Cover Your Down Payment! . . . and we'll gladly arrange for convenient monthly payments for the balance.

ACT: Write Now For Details on Valuable Protected Franchise. Your Area. Reserve Your Territory Today!

## GENERAL ENGINES CO.

Dept. MF-24, 307 Hunter Street, Gloucester, N. J.

SAY YOU SAW IT IN POPULAR MECHANICS



# IMPORT PAYS BIG!

says B. L. MELLINGER, Exporter-Importer

**NEW WORLD TRADE BOOM OFFERS BIG PROFIT OPPORTUNITY** to ambitious Men and Women everywhere. I'll show you how you may import thousands of desirable products at low foreign prices for buyers in your locality at high U.S. Prices—how you can operate a world-wide mail-order Import-Export business from home whether you live in a big city, or small town.

*B. L. Mellinger*

### HERE'S PROOF!

As startling first-hand proof I will send you an actual import from overseas, AT MY COST—something to see and use. Just mail me 25c in coin and I will rush you this Imported Nelson Automatic cigarette lighter—made to retail in the U.S. at \$2. This significant Import will convince you of the tremendous profits being made in World Trade.

### GRASP THIS OPPORTUNITY TODAY!

Send for your Nelson Automatic cigarette lighter now and I will include full details that show you how to learn my Big Profit secrets of World Trade—complete instructions that will put you on the road to a Profitable business of your own. Opportunity to travel abroad for profit and pleasure. I'll also show you how you can save many dollars on your own purchases of Clothes, Tools, Gems, Antiques, Watches, Cameras, China, Silks, Toys, etc. You can have the complete details FREE without ordering the lighter if you wish, but I would like to send you the Nelson lighter as an actual demonstration of Import Values. Either way, mail coupon Now. Airmail reaches me overnight.

The Mellinger Co., Dept. No. 252 1717 Westwood, Los Angeles, 24, Calif.

### Start at Once Without Capital

or previous experience. Fantastic profits are possible. My training also includes stipend in you of many simple imports from around the world.



HERE'S MORE PROOF!

"We operate a Profitable World Trade Business from our home . . ."

**THANKS TO MELLINGER"**

Mr. & Mrs. Bekt, N.Y.



### MAIL COUPON NOW!

The Mellinger Co., Dept. No. 252 1717 Westwood Blvd., Los Angeles 24, Calif.

Mr. Mellinger: Show me the big profits to be made through World Trade. I enclosed 25c in coin. Send me one Nelson Cigarette lighter and your plan that shows me how to learn the secrets of World Trade.  Just send your FREE World Trade Plan.

Name \_\_\_\_\_  
Address \_\_\_\_\_  
Town \_\_\_\_\_ Zone \_\_\_\_\_ State \_\_\_\_\_

# HOW I RAN A SHOESTRING INTO A FORTUNE



Dimes and nickels collected for me by my vending machines have made me worth a quarter of a million dollars — just since I got out of the Navy.

I'm willing to show others how to do what I did. Don't get me wrong. I have nothing to sell except my secret of success and complete instructions for doing what I did—starting with a "peanut" investment and just a few little machines. I have no machines to sell, no products to push, no axes to grind for manufacturers of such machines. No, I just give you all the facts I learned in six years—facts that cost me years of time and thousands of dollars to learn—but facts that will enable other men and women to enjoy the same prosperity I now enjoy. If you can imagine a man making his collections from his machines in a 1954 Cadillac coupe, you have some idea of the big money to be made—by those who know what to do and what not to do. I tell you everything. Send me your name on a post card. I'll send you complete information about my amazing Instruction Manual that shows you how to start, how to expand fast, how to succeed where others have failed, how to go right into highly competitive fields and clean up, what machines to start with, where to place them, how to service and collect the money; what to buy others—and everything you need to know—including the pitfalls to be avoided. My complete Instruction Manual is known as the Supermatic Reports. Send for Free information about this Manual at once. It won't cost you a cent to find out about the big future in Vending Machine businesses that wait right now for novices to step in and seize. No charge—no obligation—no salesman will call on you. All will be mailed, free of charge and postage prepaid. Write to **Norval Schneringer, 1209 Calhoun Street, Houston, Texas.**

## AIRMAIL STAMPS! - 10c

Here's your miniature collection of imported airmail stamps from all over the world. Extra: free 16 page treatise on airmail.



Whether you are just starting out or a seasoned stamp collector, you will want to get off to a flying start with this miniature collection of beautiful, valuable airmail stamps from the world over. Our staff has spent long hours obtaining this unusual offering. Frankly, we're going overboard to give you this high value because we want you to know about us and our vast assortment of all kinds of stamps. We are now celebrating our 14th year of satisfied customers—so you can do business with us with confidence! We haven't too many of the special miniature airmail collections available—we suggest you send us your order without delay.

FREE: with every order—a new 16 page treatise on the romance of airmail, complete with illustrations of important airmail stamps.

**JAMESTOWN STAMP COMPANY  
DEPT. #725 JAMESTOWN, N. Y.**

Send me a complete miniature collection of world-wide airmail stamps—plus the free 16 page airmail treatise. I enclose 10c to help cover the cost of the stamps. I understand there is no postage or handling charge.

Name \_\_\_\_\_  
Address \_\_\_\_\_  
City \_\_\_\_\_ State \_\_\_\_\_

MAIL TODAY

# GET 150 MILES PER GALLON

## ENGINEERS HAVE PROVEN THIS POSSIBLE

The New Improved Electronic Spark Intensifier is only one of the many ways you can gain "peak" performance. The manufacturer guarantees the following results or it costs you nothing:

- ✓ Quick Starts On Cold Mornings
- ✓ More Power
- ✓ Better Mileage

Easily installed in the center hole of the distributor cap of all cars, trucks and tractors, the intensifier boosts the high voltage passing through the distributor . . . giving a "hotter spark." This permits a wider spark gap which reduces misfiring and consequent ring and cylinder wear. A built in resistor protects plugs and other ignition points. **FREE TRIAL**, send \$2.00 cash, check or money order . . . if not fully satisfied, return for full refund.



**ELECTRONIC DEVELOPMENT CO.**  
Dept. ES-2, 10418 Venice Blvd. Culver City, Calif.

## Cartoon the EASY way!

**ORDER THIS KIT TODAY!**  
Make your own cartoons for fun and profit. No skill needed. Plastic template with cut-out spaces and holes for you make over 200 different cartoons. Kit also includes illustrated instructions, helpful hints book and information on selling. Only \$5.95 COD in USA plus post. postage. Send check or M.O. and we pay postage. Order today—or rush done for you.

**J. HOUSTON MAUPIN, Dept. 50, Tipp City, Ohio**

## Say You Saw It in POPULAR MECHANICS

### MEN . . . SHAVE . . . MEN

Get weeks of satisfying shaves from double edge blade. **RESULTS FULLY GUARANTEED**  
For detailed instruction RUSH 25 cents TO **F.H.K. INDUSTRIES MORRIS PLAINS, N. J.**

## YES! SEND



directly to my door every month

- I am enclosing
- \$3.50 for 1 year
  - \$8.00 for 3 years

name \_\_\_\_\_  
address \_\_\_\_\_  
city \_\_\_\_\_ zone \_\_\_\_\_ state \_\_\_\_\_ A-24

Hand this order to your newsdealer or send it to  
**POPULAR MECHANICS  
200 East Ontario St. Chicago 11, Ill.**



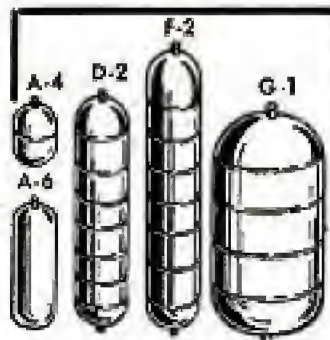

# STEEL AIR TANKS

Steel pressure tanks suitable for compressors, pneumatic units, gases, hydraulics, and liquids. Rated at 500 lbs. per square inch pressure. 1/2" standard pipe thread openings on tank ends as shown.

	Size	Wt. Lbs.	Volume	Price
A-4A Carbon Steel—New	7 1/2"x5 1/4"	1 1/2	104 cu. in.	\$1.50
A-4 Stainless Steel—New	7 1/2"x5 1/4"	1 1/2	104 cu. in.	2.50
A-6 Carbon Steel—New	14 1/2"x5 1/4"	3 1/4	280 cu. in.	3.50
D-2A Carbon Steel—New	24"x6"	5	500 cu. in.	4.50
D-2 Stainless Steel—New	24"x6"	5	500 cu. in.	7.50
F-2A Carbon Steel—New	45"x6"	11	1000 cu. in.	8.50
F-2 Stainless Steel—New	45"x6"	11	1000 cu. in.	9.50
F-1 Stainless Steel—New	18"x10"	12	1000 cu. in.	8.50
G-1 Stainless Steel—New	24"x12"	18	2100 cu. in.	12.50

Prices F.O.B. Chicago, include approx. postage on orders paid for in advance. C.O.D. orders collect 25%, balance sent C.O.D.

**U. A. S. Corp.** Dept. PM2, 5637 W. 63rd Pl. Chicago 38, Illinois

NO TANKS USED  
NEW IMPROVED METHOD

## ELECTROPLATE

ANY OBJECT IN HOME, SHOP, GARAGE OR STREET  
YOUR OWN WELL-PAYING ELECTROPLATING BUSINESS



NOW, using NEW plating kit.

It's easy to electroplate any object. Complete kit and instructions on plating metal and non-metal objects, with nickel, copper, chrome, gold, etc., plus full data on obtaining all the business you desire and making BIG MONEY full or part time. ONLY \$5.95. SEND NO MONEY—very thing sent C.O.D. plus postage—OR send \$5.95 now and receive it postpaid. Money back in 7 days if not satisfied.

M. Z. NATIONAL SALES CO., 144-T Henry St., N. Y. 2, N. Y.



## MASTER MIND!

### Learn Short-Cut Mathematics

Jazzie figures, do baffling number tricks. Make people gasp at your amazing feats—order yours today. Multiply 4 figures by 4 figures without using old-fashioned multiplication! Big cloth-bound volume fully illustrated course.

### Sharpen up Your Brain Power

Includes worked out problems, answers, etc. Sensational bargain, only \$2.95, postpaid or C.O.D. plus postage. Satisfaction guaranteed or refund. Order this amazing "Short-Cut Mathematics" today!

**NELSON-HALL CO.,** 210 S. Clinton St., CHICAGO 8, ILL. **\$2.95 Complete**

## Say You Saw It in Popular Mechanics

### AMAZING NEW POCKET SIZE RADIO

Really Works—Small as a Pack of Cigarettes!



FITS IN ANY POCKET OR PINEAPPLE—RECEIVES LOCAL RADIO STATIONS WITH CLEAR HILL-LIKE TONE—NO STATIC OR INTERFERENCE! NEEDS NO TUBES, BATTERIES OR COMPLICATED HOODLUMS! NO AC PLUG! NOTHING TO WEAR OUT. Thousands of others—many report years of service. Use a new crystal, diode and 12-12 cell. **SEND NOW!** DON'T ASK FOR SEARCH PHONES—Just the tiny radio to take with you ANYWHERE YOU GO—ON TRIPS, VISITING, ETC.—for real fun and enjoyment—ANY TIME. **SEND ONLY \$1.00**

(bill, ck., mo.) send pay postman \$2.00 C.O.D., postage or send \$4.00 for P.O. delivery. COMPLETE READY TO LISTEN. MIDWAY CO., Dept. PMW-2, Kearney, Neb.

## Wheels Wheels



## Wheels Wheels

- 7" Disc Wheel 3/4" Tire 3/4" sleeve.....45c ea.
- 8" Disc Wheel 1 1/4" Tire 3/4" sleeve.....70c ea.
- 7" Disc Wheel 1 1/4" Tire 1/2" ball bearing.....80c ea.
- 8" Disc Wheel 1 1/2" Tire 1/2" ball bearing.....\$1.00 ea.
- 8" Disc Wheel 1.50 semi-pneum. Tire 1/2" B.B.....\$1.25 ea.
- 8" Disc Wheel 2" semi-pneum. T. 1/2" B.B.....\$1.50 ea.
- 10" Disc Wheel 1.75 semi-pneum. T. 1/2" B.B.....\$2.00 ea.
- 10" Disc Wheel 2.75 semi-pneum. Tire 3/4" B.B.....\$3.00 ea.
- 12" Disc Wheel 1.75 semi-pneum. T. 1/2" B.B.....\$1.85 ea.

Above wheel prices include hub cap. Plus postage. C.O.D.'s accepted. AXLES—Sizes 5/16 in., 3/8 in., 1/2 in.—Cut to size—End holes drilled.

**UNITED WHEEL STAMPING CO.,** 12131 S. PEORIA STREET PM-2 CHICAGO 43, ILLINOIS

# MEN - WOMEN RAISE ORCHIDS

IN YOUR LIVING ROOM!

YEAR 'ROUND

No Greenhouse Needed

Any Climate, Maine to California

BIG PROFITS!

Spare or Full Time. Loads of Fun for all the Family!



Fill your home with gorgeous Tropical Orchids. Thrill to the gorgeous beauty of your very own huge purple Cattleyas like those you see in nearly every flower shop. Exquisite Cymbidiums, sometimes with 30 or more blooms on each stalk. Hundreds of others—many grow without soil, getting food from the air. Yellow Orchids, greens, blues, pinks, browns, every rainbow color. No greenhouse needed. Start on card table in your living room. Any climate. Maine to California!

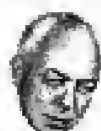

### Successful Home Grower SHOWS YOU HOW

Louis Schirmer, successful home grower, shows you step-by-step how he and Mrs. Schirmer started with a few plants at home, developed a big-profit business, and grew an orchid collection now worth a fortune. Learn how orchids multiply—how one plant may become many, each as valuable as the first. No big investment.

LOUIS SCHIRMER Orchidist

No overhead. Takes few minutes a week. Big-profit orders come from individuals, florists, hotels, clubs, etc. Popular year-round gift. Millions sold by Mail-Order. Schirmer shows you how!



You can grow gorgeous Cattleya Orchids like this in your own home!

Home Growers Count to Count Details from Schirmer's Help

- A wonderful color, written as simple as "show-how"
- 144 pages
- Illuminated with 100 color plates

Complete Instructions and Living Orchid Plants Sent for You to Examine at Home Without Risk

Complete Directions—secrets of the experts—in simple language, jam-packed with "show-how" drawings, gorgeous full color pictures of orchids. Also a real blow-up-size orchid plant from the Schirmer's own Gardens. Everything you need to start is yours to examine at home, without risk. FREE—full details. Learn how you may become an Orchid Grower. Send no money! Write today, Airmail is 94¢ each.

**TROPICAL FLOWERLAND Dept. 312**  
4082 Wilshire, Los Angeles 3, Calif.

## MAIL COUPON NOW!

Tropical Flowerland Dept. 312  
4082 Wilshire, Los Angeles 3, Calif.

Rush me complete free details on your offer of Louis Schirmer's Instructions which show me how to grow Tropical Orchids at home. The instructions will include a blooming-size Orchid Plant and valuable Home Profit-Plan. This request does not obligate me in any way.

Name \_\_\_\_\_  
Address \_\_\_\_\_  
City \_\_\_\_\_ Zone \_\_\_\_\_ State \_\_\_\_\_

# Start a profitable manufacturing business in spare time

with your own home as your headquarters



**R**IGHT at this moment there is a tremendous demand for new business enterprises in a branch of the plastics industry. Fortunately, this is a type of manufacturing business that does not require heavy or expensive machinery, rented space for storage, production or sales. A portable hand machine does the work wherever electric current is available, and the working area can be in almost any part of your home.

The opportunity that is open to you today, is to meet this growing demand in a new industry by establishing yourself as the manufacturing agent in your own trading area. Several hundred of our machines are already in use in both large and small communities. Some are even being operated successfully by women whose family duties make it necessary for them to be at home during the day, but whose family income is not enough to meet rising expenses. Most are being operated by men. Many started in spare time just to pick up an extra five or ten dollars for an evening's work. They found the work so profitable that some have now given up former jobs to devote full time to a business of their own.

One of our manufacturers gets all of his business by mail. Orders and money come to him in envelopes and he sends his products out the same way. Another delivers his entire output to stores in the vicinity. An-

other does a wholesale business supplying other manufacturers who do the selling. Still another works with advertisers in the manufacture of plastic advertising novelties and specialties.

The operation of the machine is simple and easy for anyone to learn. It does not require any knowledge of chemistry, mechanics, or electricity. And what some say is best of all, a manufacturing business like this enables a person to make good money without any house to house canvassing. The machine turns out from \$5.00 to \$15.00 worth of work per hour and it can be operated for as short or long a time as you wish.

We have prepared a simple step by step instruction manual that not only tells how to operate the machine, but also tells how to get the business coming in at a profitable clip right from the start. We will lend a copy of this book to any serious minded man or woman with the

understanding that a copy will be given them free if and when they purchase a machine—or the copy we lend can be returned if you decide not to go into the business. Reading it will not cost you anything.

If you are interested in a nice little home business that can bring in an extra \$60 or more for ten or twelve hours work in spare time, send your name. All information on the book and machine will be sent free, postage prepaid and no salesman will call to bother you. You read about it in the privacy of your own home without outside pressure and then decide whether you'd like to take the next step. Address your envelope to me in person. Send me the coupon below. Or, if you prefer send your name on a post card and ask for "Free information on starting a manufacturing business at home." Either way, send your name today and find out about this wonderful new fast growing money-making business.

RAYMOND E. BRANDELL

1512 Jarvis Ave., Dept. L-10-B, Chicago 26, Ill.

Raymond E. Brandell, 1512 Jarvis Ave., Dept. L-10-B, Chicago 26, Ill.

Dear Mr. Brandell: Please send information showing how I can start a profitable manufacturing business in my home in spare time. All the information you send will be mailed to me free of charge and no salesman is to call on me. I am not under any obligation to go ahead with the business and there is no charge for this information now or any other time.

Name \_\_\_\_\_

Address \_\_\_\_\_

City \_\_\_\_\_ Zone \_\_\_\_\_ State \_\_\_\_\_

POPULAR MECHANICS

**WORLD'S  
BEST  
WANT AD  
MEDIUM**

# CLASSIFIED Advertisements



Advertisements in this section \$1.00 per word, each insertion, minimum 10 words, payable in advance.

To be inserted under proper classification, copy must be in our office the 20th of the second month preceding date of issue

F. W. Johnson, Manager, Classified Advertising

Popular Mechanics Magazine, 200 East Ontario Street, Chicago 11, Illinois

## YOU'LL PROFIT

By reading and answering the classified ads in this section. Hundreds of opportunities for you to make and save money

### AUTOMOBILES. MIDGET CARS

**FIBERGLAS** Automobile bodies. Build your own. Maurice Lanson's Fiberglass "How" book—\$2.50. Information, materials catalog, 10c. Airmailed, 35c. Gem-O-Lite, Box #807A, North Hollywood, California.

**BELL**, Restored 1936 Cord—\$1500.00. Pictures, \$1.00. Greenlee, Box 1036, Anderson, Indiana.

**GERMAN** Automatic toy car manufacturers complete address list \$1.00. Burke Associates, Manchester 1, Mass.

**TWENTY** Ways to make money with your car. Complete plans. New booklet, \$1.00 prepaid. Strickland's, Box 447, Longmont, Colorado.

**FREE** Motor magazines; automobile literature, old, new and foreign; glossy photos, dealer books; shop manuals—Offered with non-profit organization. Write today; get on free mailing list. Auto Mania's, Brockbridge, Mich.

**ANTIQU**—Classic—custom—sports. 6474. Buy, sell, swap. "A.T.S." Lists hundreds twice monthly. Sample 15c. Automotive Trading Service, Box 1184, Akron 9, Ohio.

**RACING**, Rodding, restyling requirements. Wholesale-retail. At Price, 64 Afton PM-2, Rochester 12, New York.

**GENUINE** Motor treatment, Lachapelle's. (patented). Only \$2.00 delivered. Restores compression, power. Saves gas, oil, repairs. Money back guarantee. You can't lose. Free circular. Write Joe Dillon, Authorized Warehouse and Agency Distributor, Box 323-R, Bridgeport, Ohio. Distributorships, agencies open.

**BALANCE** Wheels without special equipment. Save money—Make money. Box 316, Berkeley City 21, Mo.

**1954 SUPERIGNITIONER**—Starting, pep, mileage. \$4.50. Barbells \$16.00, EG, Elmford, New York.

**200 MILES** Per gallon claimed by inventor of patented carburetor. Complete details and drawings \$2.00. Extremely interesting. Behling, Box 935, Dept. 1, Inglewood, Calif.

**HT-MITRAGE**—speed equipment from the world's largest supplier. Dual manifolds, finned heads, electric doors, lowering sets, chrome panels, thousands of items for all cars. 1954 catalog 25c (illustrated literature free). Wholesale to garages. Newhouse Automotive Industries, Los Angeles 22.

### AUTO SUPPLIES AND EQUIPMENT

**RADIO** Control your garage door from car. Complete plans, drawings, Send \$1.00. Don Chilton, 109 So. Carondelet, Los Angeles, Calif.

**SAFETY**. Be safe in fog, snow, rain or dust with patented Safetyfog filter. Fits all sealed beam headlights. Penetrating amber light attached with suction cup. \$2.00 prepaid. Safetyfog Filter, 120 S. Fritchard, Fullerton, Calif.

**SAVE** Money! Stop burning excess oil with Dana's Engine Treatment. \$2.00 postpaid. Dana's, R.F.D. 1, Coupeville, Wash.

**NEW** Type emergency fire chains. Most convenient, sturdy. Motorist's friend snow, mud. Quick on. Guaranteed. \$5.98 set (4), prepaid. Name car, tire size. Koenig-Kunt Chain Co., 1405 Cherokee Road, Richmond 25, Va.

**CUSTOM** Accessories headquarters. Electric push button doors-trunks, ball noses, custom grilles, speed dress-up equipment, 40 page catalog hundred photos—25c. Eastern Auto, 3319A South Grand, Los Angeles 7, Calif.

**BUY** Wholesale nationally advertised auto supplies, thousands other products at big discount. Free "wholesale plan." American Buyers, 628-DD Linden, Buffalo 16, New York.

**BUILD** Your own custom 1954 low cost Fiberglass body. Construction manual \$1.00. United States Fiberglass-Resin Company, 722 East Washington, Los Angeles 21, Calif.

**SEND** No money! Order original Gale Hall gasoline economy and motor condition gauges on sensational free trial basis! Install on dashboard... try at our risk for seven days! Then return payment or gauge! Originally \$7.50, now only \$2.98 plus 40c postage! New England Surplus Sales, 67-PM2 High Street, Newburyport, Mass.

**NEW** Auto spark plugs, 14mm and 18mm. Universal type \$16.00 per hundred; rivet set kits \$3.95 ea.; aircraft safety belts \$2.30 ea.; piston ring sets, Chev., Ford, etc., all makes, 8 sets \$12.50. Leikee Supply Co., Selma, California.

**WHOLESALE** Automobile supplies. Catalog 25c (refundable). Charles Wholesale, Batesville, Arkansas.

**REFLECTING** Combs bumper stickers only 15c each. Stonaker, Box 3503B, Jacksonville, Fla.

**FIBERGLAS**—Plastics for bodies and hardware. Complete building instructions. New low prices. Nationally known suppliers. Industrial Plastics, 4425 Linden, Oakland 8, Calif.

**NEW** Crumbliss Super Coil. literature. Also special automotive tool catalog. White's, Calmar, Penna.

**LACHAPPELLE'S** Treatment. (Patented.) Puts ballbit bearings on the cylinder walls for the pistons to slide on. Only \$3.00 postpaid. Write, Ferns Products, 2120-B Walnut Dr., Los Angeles 1, Calif., for free information.

**RADIATOR** Sealer \$1.00 postpaid. Guaranteed. For cars, trucks, tractors. Expert Radiator Service, 115 2nd Street, East Liverpool, Ohio.

**BUCKET** Seats, airplane, plywood, 12 1/2, new, \$3.95; 2" safety belt, \$2.00. Aeroparts, 8442 Travelair, Houston 17, Texas.

**TIRES**—First quality, lifetime guarantee. Unbelievable discounts. Free catalog. American Tire Co., 155 Truman, New Haven, Conn.

**"LITE-A-Bumper"** reflector tape for night driving safety. 6 ft. strip and 12 diamond markers \$3.00 postpaid. Henry Mfg. Co., Dept. M, Minneapolis 15, Minn.

**SOMETHING** New! "Battery Guard" indicating light mounted on car dash shows whether or not battery needs water. Five minute installation, any car. No drilling dash. \$1.50 complete. Guaranteed. Order c.o.d., cash, check, m.o. or ask for details. Loran Products, 124 Morton St., Rochester 9, N. Y.

**CARBURETOR** Flanges for vacuum controlled valve oilers, water injectors, vacuum gauges, etc. Send \$1, make and model cat. Flanges, 253-E Angelino, Burbank, Calif.

**ELECTROPLATE** Auto parts, novelties, mirrors. Easy, inexpensive home processors. Free booklet. Tyco Metals, Box 13331-BO, Houston 19, Texas.

**MODEL T** Ford parts, engine and chassis. Parts for other make old models too. Special parts made to order. We also buy surplus items. B. S. Wisneski, Inc., Milwaukee 3, Wis.

**CHEVROLET** Owners: Stop tappet noise with Kaye Tappet Silencers. Quality product. Easy to install. Complete set \$5.95. Kaye Products, 2067 B S. Layton Blvd., Milwaukee, Wis.

**NEW** And used guaranteed parts for civilian and army cars and trucks. Largest stock in America. Mail orders. Pioneer Auto and Truck Parts Co., 734 W. 13th Ave., Denver, Colorado.

**"WATER** Injection." Free descriptive, illustrated, information. Neher Industries, LaVerne, California.

**BRUSH** Plating outfits connect to a battery. No tanks or shop required. Free particulars. Quametal Co., Ave. J, Decatur, Ill.

**CAR** Burning oil? Losing compression? Try Clifford's Compression Seal. \$2 postpaid. Clifford's Engineering, 1329 Seventh, Aurora, Illinois.

### AUTO TRAILERS

**THREE** Room trailer, Blueprint \$1. Circulars 20c. Craftsman Books, Box 1153, Milwaukee 1, Wis.

**EXCEPTIONAL** Expanding eight foot trailer. Accommodates family of five. Build yourself. Literature 10c. Fra-Mar Company, Jones Avenue, Wilmington, Mass.

**ALUMINUM** Camp trailer kit. Campers, hunters, fisherman, sleeps four. Compact, folding. 560 lbs. Literature 10c. Master Camper, West Sayville, N. Y.

**BUILD** Your own trailer! Plans for all kinds. Illustrated catalog 10c. Jim Dandy, 125-M, Wausau, Wisconsin.

**CATALOG**—Largest in midwest. Newest items. Send 10c. Hanna Trailer Supply, 615 W. Layton Ave., Milwaukee, Wisconsin. Dept. MP.

### MOTORCYCLES, BICYCLES, MOTORSCOOTERS AND SUPPLIES

**1953** MATCHLESS Scrambles model in original crate with complete road equipment. Will make real low price for cash. P.O. Box 1261, Portland, Oregon.

**WHIZZER** Motorbike \$25.00; Doodlebug motorscooter \$35.00; Servicycle \$30.00; Harley Twin \$25.00. Rush 25c (35c first class mail) for catalog #955 listing many other amazing bargains in motors, midget cars, motorscooters, motorbikes, construction plans. Associated, Box 334, Toledo, Ohio.

**SAFETEEMITT** Makes night hand signals readily visible up to 300 yds. Brilliant reflective tape back and front. Snaps on hand or over glove. Recommended police and safety councils. \$1.50. Safeteemitt, U.S. P.O. 388, Blaine, Wash. — Canada, 1286 Homer, Vancouver, B.C.

**NEW** Wasp 4 cycle bicycle engine kits. Ready to install in bike. Cauffiel Motor Industries, Temperance, Michigan.





**\$5.00 MONTHLY** Buys 5 acres, excellent fishing and hunting; good land; price **\$120.00**. Free list. Box 425-P, Carthage, Mo.

**FLORIDA'S** Choicest lakefront lots. East-DeLand highway. \$10 monthly without interest. Free literature. Roepke, East-DeLand, Florida.

**FLORIDA**—New development adjoining Ocala National Forest in Lake County. Best fishing, hunting. Nice homesites \$245 at \$10 monthly. Folder free. Howard Vernon, DeLand, Florida.

**FLORIDA**—Beautiful retirement homesites near gulf coast. Excellent hunting, fishing in 9 fresh and salt water rivers, 11 bays and gulf, \$250 at \$10 monthly. Free literature. A. M. Mathews, Box 1406, Asheville, N. C.

**HOMESITES** \$400—Convenient payments. California's finest garden section. On Morro Bay's scenic shores. Wonderful fishing, boating, bathing. Fertile soil, softest water, temperate climate, congenial community. Free literature. Richard Otto, Department M, San Luis Obispo, Calif.

**FLORIDA** Choice lakefront lots available. Best fishing, hunting. Terms. Great Parker, Paisley, Florida.

### FARM MACHINERY AND SUPPLIES

**\$135.00** — **KENTRAC** Garden tractor, \$335.00. Sturdy 2-h.p. tractor, four forward speeds, over-riding catches, 5-12 tires. Nationally known make. Direct to consumer saves you money. Complete set of attachments available. Send check or money order. Descriptive literature free. Kentrac Co., Box 373, Kent, Ohio.

### POULTRY, FARM SUPPLIES

**RAISE** Turkeys the new way. Write for free information explaining how to make up to \$2000 in your own backyard. Address—National Turkey Institute, Dept. 3, Columbus, Kansas.

**POULTRY** Farmers, broiler growers, turkey raisers read the new American Poultry Journal for latest ideas and greater profits. 12 months, 50¢. Special offer, 4 years, \$1.00. American Poultry Journal, 182 North Wabash, Chicago.

### PROFITABLE OCCUPATIONS

**WELDING** Pays big money. Learn easily at best equipped school in country. Non-profit school with low cost training. G. I. approved. Write Robert Trade School, Box M-242, Troy, Ohio.

**MEN** Wanted. Build luggage and cases at home. We sell your products. Complete instructions. No special equipment needed. Free details. Cascraft, 805-P3 Sunset Blvd., Los Angeles.

**SEND** For big, new 1954 illustrated catalog that will show you how to turn your spare time into cash—making quick-selling, highly profitable lamps. Every home a prospect. Hundreds doing it, you can, too. No experience or special tools required. Catalog No. 7 contains 56 plates filled with shades, shade frames, figurines and bases, oil lamp converters, boring compound, and dozens of similar items. Also all kinds of sockets, cords, pipes, harps, finials, bases, and hundreds of other parts—everything you need. Special 3-page section shows 5 beautiful lamps in kit form, ready to assemble. You buy wholesale, sell at retail. Make big profits. Send 25¢ today for new 1954 catalog and wholesale price list. You'll be glad you did. The 25¢ will be refunded on your first order. Georon Co., Dept. 566-B1, 27 S. Desplaines, Chicago 8, Ill.

**"HOW To Build Your Own Home Mail Order Business."** Beginners instruction handbook. 25¢. Carnahan Bros., 3392-A Nelson, Cypress, Calif.

**"HOW To Make Money With Simple Cartoons"**—A book everyone who likes to draw should have. It is free; no obligation. Simply address Cartoonists' Exchange, Dept. 82CP, Pleasant Hill, Ohio.

**WANT** A diesel job? New opportunities to increase income. Higher pay. More money. We can help you qualify. Tools. Shop method home training. Write today! Diesel, Tractor, Heavy Equipment Division. Interstate Training Service, Dept. B2E, Portland 13, Oregon.

**\$10,800 PROFITS!** Your own mailorder business! No risk! Success plan free! Treasury, 308 Webster, New Rochelle L-30, N. Y.

**NEED** More money to live on? Increase your weekly income \$20 to \$25 or more in spare time. Supply Rawleigh Products to consumers. Also openings for full-time dealers. Write Rawleigh's, Dept. B-DD-FPM, Freeport, Ill.

**BUY** Wholesale thousands nationally advertised products at big discount. Free "wholesale plan." American Buyers', 626-N Linden, Buffalo, N. Y.

**LOS** Angeles job opportunities. For office, factory and professional workers, skilled and unskilled labor. Information on living conditions and copy of big daily paper with classified ads for hundreds of men and women only \$1.00. Admt, Box 1188, Hollywood 28, Calif.

**FLORIDA** Jobs. Florida needs you. Live and work on the fabulous gold coast. Hundreds of good jobs for skilled and unskilled men and women. For information send your name, address and \$1 to Florida Personal Institute, Dept. A, Box 2058, Miami 12, Florida.

**EVERYBODY** Likes candy. Learn to make professionally. Our 44th year. Ragdale Candies, 66, East Orange, New Jersey.

**MEN** Earn \$1,500.00 per month on foreign projects. Men wanted now on foreign, Latin America and Far North projects. Truck drivers, \$3.55 hour. Laborers, \$3.00 hour. Electricians, \$4.00 hour. Carpenters, \$3.70 hour. Clerks, \$3.50 hour. Most all trades wanted. Up to 70 hour week with time and one half for all over 40 hours. Transportation paid. \$ to 24 month contract. New treaty with Spain, South Korea will start new bases at once. Get in on start. Full information of all items hiring, living conditions, family accommodation, wages, hours, age, contract requirements, application form also latest issue of our monthly bulletin listing new contracts and coupon worth \$1.00 on subscription. All for \$1.00. Air mail \$1.24. Edward O. Burns, 911 N. Lancaster Avenue, Dept. 8, Dallas 3, Texas.

**ANNOUNCING** Home study course in commercial baking. Practical basic training. Good field for those with aptitude. Free booklet, "Opportunities in the Baking Industry." National Baking School, 335 Diversey Pkwy., Dept. 3432, Chicago 14.

**MAKE** Finest costume jewelry. Easy, profitable. Wholesale catalog 20c. Bergen Arts, 12344 Main Street, Hackensack, N. J.

**MUSHROOMS** Grow boxes, barrels. Matureless process 50¢. Spawo \$1.00. Gordons, 353 William, Winnipeg, Manitoba.

**BECOME** Patent firm representative. Spare time, mail order. Experience unnecessary. Work done Washington office. 500 receive sensational income! Industrial Patent Reports, Box 6295, Washington 15, D. C.

**SELL** Popular Mechanics and all other magazine subscriptions. Free catalog, supplies. Subscription Service Company, Dept. B, P.O. Box 2076, Birmingham, Ala.

**TRAVEL** Business employment. Where, how to apply. Free particulars. Travelpost, Box 578, Jacumba, California.

**INTERNATIONAL** Reports on who to contact for highest paying jobs in 28 countries, including United States, Spain, Alaska, South America, Middle East. Listings of employers with contracts who hire skilled, unskilled, professional, supervisory, clerical, laborers, trades, and many others. Many average \$1500.00 monthly. Also best oil and aviation opportunities. Only \$2, including one year registration and advisory service. Also application blanks. We can help you find employment. The only service that guarantees complete satisfaction or your money back. International Reporter, Box 1047-P, St. Louis 1, Missouri.

**FOREIGN** Employment—U.S. companies need personnel. Now! Immediate valuable information, applications from leading job information bureaus, \$1.00. Additional free information on Brazil, California, Florida, Hawaii, etc. Worldwide Job News, Box 271, Temple City, California.

**SENSATIONAL** Free trial bargain offer! Send no money! Try famous Gale Hall professional automotive instruments for one week, then return payment or merchandise! Compression gauges, originally \$10.75, now only \$3.98! Engine analysts vacuum gauges, originally \$12.50, now \$4.55. (40¢ each postage.) New England Surplus Sales, Dept. FM-3, 67 High Street, Newburyport, Mass.

**RAISE** Pheasants on \$100 week plan. Little capital and space can make you independent. Free details. Great Central System, Columbus 1, Kansas.

**MEN, Housewives, handicapped persons.** Steady, easy income with your own full or part-time plastic repair business. Be independent. We furnish complete stock and advertising. Send \$1 (eliminates curiosity seekers) to Kenway Products Co., Minden, Louisiana.

**\$1300.00 MONTHLY** For truck drivers, \$1400.00 monthly for carpenters, electricians, plumbers, mechanics, \$1200.00 for clerks and laborers. Replacement hiring now being done. Full information and complete foreign listings, with current information on Spain job, \$1.00. Women's Listings, \$1.00, 25,000 men and women needed for new statewide project! Complete information and other domestic listings, \$1.00. Dept. 3-B, Opportunities Unlimited, 1110 Commerce Bldg., St. Paul, Minn.

**FOREIGN, Latin American, domestic employment.** 1954 "Foreign Service Directory" originator of job news by copyright, gives up-to-minute facts on military and civilian construction; Canadian, Alaska construction; major oil companies; aviation; manufacturers; steamship lines; mining; importers-exporters; how-when-where to apply with application form. Free—Hot list firms hiring, \$1.00 postpaid. Global Reports, Box 333-P, Hollywood 28, Calif.

**40 WEEKLY** Made growing mushrooms. Fresh, dried, Dominion patent 331,583. Free spawn. North American, 169 Yonge, Toronto, Canada.

**PROFITS** To \$5 hour! Engraving plastic titleplates, novelties. New universal engraving machine "Duplicolor." Sample, details 25¢. Deaso Distributors, 8334-A Sepulveda, Van Nuys, Calif.

**ALASKA** Job list. High wages. Labor \$3.27 hr. Plumbers \$4.00, truck drivers \$3.37, carpenters \$3.34, etc. Homestead and Alaskan highway map and directions. Application blank with job list, \$1.00 postpaid (e.o.d. \$1.87). Alaskan Jobservice, Waseca, Minn.

**FREE!** "301 Profitable Small Businesses!" Amazing shoestring plans! Work home! Start sparetime! Deumant Surveys, Kenmore 23-R, N. Y.

**\$1900 TO \$450** Paid for truck drivers, carpenters, doctors, laborers. Foreign and domestic jobs. Fare paid. South America, Alaska, Africa, Far East, etc. Latest information on Spain job. Big statewide job, 25,000 men and women needed, skilled and unskilled trades, office, etc. Many jobs in foreign lands. Send for details. How-when-where to apply. Foreign Job Service, Waseca, Minn.

**LEARN** Metalizing baby shoes, gifts, etc. Bronze, gold, silver. Polio free. Kiklav, 7217-MK South Broadway, Los Angeles 3.

**HONOLULU** Help wanted outcasts air-mailed \$1.00. Sterling's, #3 Campbell Block, Honolulu, Hawaii.

**ALASKA!** Last American frontier. \$1.00 brings 1954 business directory and government map. Military and civilian construction; homestead and highway facts; mining, aviation, fur farming, grazing, timber, travel directions. List of firms hiring. How to apply. Alaska Opportunist, Box 92-P, Hollywood 28, Calif.

**OVERSEAS:** Contracting, engineering and oil companies; big pay, no U.S. taxes, cheap living costs. Send \$1 for list showing where to apply. ForeignJobs, Box 168, Washington 4, D. C.

**TYPISTS** — Profitable home business. Complete copyrighted information, 50¢. Gaunt, 827-W Irving Park, Chicago, Ill.

**ALASKAN** Jobs! Over 150 new construction projects with names, addresses companies hiring. Thousands needed. Highest wages. Military, private construction, mining, fishing, lumbering, aviation, railroads, homesteading. Skilled, unskilled workers. Salary information, Alaskan map included. \$1.00 complete. Alaskan Opportunities (PM), Box 343, Kenmore, Washington.

**GROW** Mushrooms. Cellar, shed, and outdoors. Space, full time, year round. We pay \$3.50 lb. We paid Babbitt \$4,165 in few weeks. Free book. Washington Mushroom Ind., Dept. 99, 2954 Admiral Way, Seattle, Wash.

**JOBS** On ships and yachts, excellent pay. Foreign travel. Davenport's, Dept. 3, Box 1354, O.P.O., New York 1, N. Y.

**MAKE** Flexible molds! Cast plaques, bookends, figurines! Free sample! H. Tooker, 619-M Cherrant, Hamilton, Ohio.

**BE** The Popular Mechanics representative in your neighborhood and earn big profits in your spare time. Write Popular Mechanics Magazine, Room 408M, 200 E. Ontario St., Chicago, Ill.









**8MM.** Movie subjects. New 150' films, \$2.95. Dome brings 32-page, 1954 catalog, 50' 8mm. Previous film and catalog, 50c. Blackhawk Films, 1233 Eastin Bldg., Davenport, Iowa.

**GIFT Certificates**—Valuable prizes with purchase of used 16mm sound films. Free 20 page bargain bulletin. Hundreds of choice subjects. Gaines, Box 114PM, Skokie, Ill.

**16MM.** Sound projectors—Excellent used units, all makes, \$119.95 up; some \$99.95. Dome brings 32-page catalog equipment, films. Blackhawk Films, 1233 Eastin Bldg., Davenport, Iowa.

**HOME Rentals**—16mm, sound features. Three days, \$3.95, including all postage, 1954 home rental list free. Eastin Pictures, Davenport, Iowa.

**16MM.** Movie subjects. New 300' 16mm, sound releases, \$11.95. Bargain prices on hundreds used 16mm, sound, silent prints. Dome brings 32-page, 1954 catalog. Blackhawk Films, 1234 Eastin Bldg., Davenport, Iowa.

**WOW!** We've got everything! Collector's items, new releases. Free catalog, Vanity Productions, Dept. 10, 95 Seneca Street, Seattle 1, Washington.

**8-16MM.** Silent-sound films. Complete rental library. All latest subjects. Free catalogue, sample film 10c. Garden Film, 317 West 50th, New York 19.

**MOVIE Camera film:** 8mm, roll \$1.50, 16mm, 100' \$1.00. Free processing. Better Film, 742 New Lots, Brooklyn, N. Y.

**TAPE Recorders,** tapes, accessories. Unusual values. Dressler, 624-M East 20th Street, New York City 9.

**GUARANTEED** Fresh 8mm, roll, magazine, 16mm, roll, magazine movie films. Color, b&w. Free catalog. ESO-R, 4724 Holly, Kansas City 2, Missouri.

**BELL & Howell** 16mm, sound projectors. Castle sound films, splicers, reels, other supplies. Free catalog. Ideal Service Supply, 4644 Geary Blvd., San Francisco 18, Calif.

#### MUSIC AND MUSICAL INSTRUMENTS

**SONGPOEMS** Wanted. Mail to Tin Pan Alley, Inc., 1650 Broadway, New York 19, N. Y.

**SONGWRITERS**—Join Amateur Songwriters Club of America. Free details. Asca, Box 433-C, Hamilton, Texas.

**BIG Money** offered new songwriters daily! Anyone can write songs by our method. Write for free secrets of profitable songwriting and free demonstration record. No obligation. No one will call. Meadowlark Music School, 255 Summer Road, Colorado Springs, Colo.

**POEMS** Wanted for musical setting. Send poems. Free examination. Crown Music Company, 1475 Broadway, New York City 30.

**HAVE A tune** and can't write music? For all those who have a tune and cannot write music, worry no more, as the Aversa Miracle Musical System actually will write the music to your tune. \$5.00 may now bring your tune to Tin Pan Alley. Refund if not satisfied. For results write Aversa System, 324 Bee, Frankfort, N. Y.

**INSTANT Piano** method, assures instant results! No piano needed! Study home, play anywhere! Send \$2. Instant Piano, B-2, Brooklyn 4, N. Y.

**MUSIC** Arranged. Songs printed. Frank Wild, Music Publisher, Lancaster, Penna.

**ACCORDIONS** And concertinas, save 50% and up. New and used. All brands. Wholesale to every one. Please specify. Free accordion or concertina catalogue. Del Principe, 29 South Cicero, Chicago 44, Illinois.

**FREE Songwriters kit**, plus name band singers recording offer. Postcard. Harmony Unlimited, 3466-B Grand, Oakland, Calif.

**POEMS** Wanted for musical setting. Send poems. Free examination. Five Star Music Masters, 830 Beacon Bldg., Boston, Massachusetts.

**SONGWRITERS:** Your song expertly arranged for piano. Send lead and \$8.00 to Zarlengo Music, 1454 Walton Street, Denver, Colorado.

**FREE Record** of your song. Your words, my melody. Free information. Johnny Mack's Melody Mart, 1094 West 39th Street, Dept. A, Los Angeles 37.

**LEARNING** Violin or viola? Here's a little pamphlet which can make a big difference in your playing thru emphasis on tone quality. Just send one dollar to M. L. Stayner, P.O. Box 1383, Salt Lake City 10, Utah. Thirty day refund period.

**YOUR Voice** made loud, clear and powerful with my diaphragm exerciser. Inexpensive. Write, Inventor Co., 34V, Box 665, St. Louis, Mo.

**ACCORDIONS** And other musical instruments wholesale. Music Center, Plymouth, Ind.

**SONGWRITERS!** Let me help you. Stamp for booklet. Mark Rubens, 146-D West 79 St., New York 24, N. Y.

**SONGWRITERS!** Protect your ideas! Hold all songs, poems! Write for safe correct procedure first! Song Service, Dept. P, 323 W. 56th St., New York 19, N. Y.

**POPULAR Songs.** How to write and sell them. Write for free booklet Successful Songwriting. Gateway Songs, Box 2470, Hollywood 28, Calif.

**SONGWRITERS!** Send poems, songs. Music Service, 243 West 12nd St., PM, New York 23.

**POEMS** Wanted to be set to music. Free examination. Send poems. McNeil, Master of Music, 530-PM S. Alexandria, Los Angeles, California.

**WRITE Songs.** Big money and reputation. Write for information, J. Gordon Pub. Co., 4700 South California Avenue, Chicago.

**1853 ACCORDIONS** Wholesale. Free catalog. American Accordion Center, 5329 Belmont, Chicago.

**POEMS** Wanted for musical setting. Send poem for immediate consideration and free rhyming dictionary. Richard Brothers, 24 Woods Building, Chicago 1, Illinois.

#### RADIO AND TELEVISION

**REPAIR** Any radio. Complete simplified instructions only \$1. State's Radio Service, Corsicana, Texas.

**BUILD** Your own electronic organ, or miniature electronic brain. Free details. Jim Kirk, 1552 Church Street, San Francisco 14, Calif.

**PICTORIAL** Construction plans. Free list. Alecta, Box 24, Astoria 8, New York.

**BUILD 15 Radios**—Only \$19.95 complete. Free radio tester, tools, soldering iron. No experience required. Money-back guarantee. Order direct or send for descriptive literature. Free valuable radio and TV repair guide on request. Progressive "Educ-Kits" Inc., 493 Union Ave., Dept. PM14, Brooklyn 11, N. Y.

**BUILD** Your own top quality TV set. We supply complete equipment, tools, instructions as part of America's finest home-study TV course. Be a high-paid TV technician. Install, repair, service all makes of sets. Many excellent jobs now open. Or start your own business. Get full facts free. Write: Commercial Trades Institute, Dept. CT2-2, 1400 Greenleaf Ave., Chicago 26, Ill.

**LEARN** Radio television \$1.00 per lesson. Electronic Communications, Box 567, Springfield, Missouri.

**24 PAGE** Plans "18 Long Distance Crystal Sets" 25c. Including "Radiohulder," catalog. Laboratories, 328-C Fuller, Redwood City, California.

**FREE** Bargain bulletins, radio and television supplies. Buyers Syndicate, 223-B Worthington St., Springfield, Mass.

**TELEVISION** Interference eliminated with amazing, easily installed, guaranteed, antenna high-pass filter. Unbelievable! Only \$1.00 postpaid. BMB Co., Box 6, Hillside Manor Branch, New Hyde Park, N. Y.

**MAKE** Simple, tubeless, batteryless distance-getting crystal radio. Crystal and illustrated instructions 35c postpaid. Allen, 427-P Clinton, Missouri.

**FREE.** Get on our radio and electronics mailing list. A.R.I., Box 1438, Denver, Colorado.

**AMAZING** Newly developed, permanently fixed crystal detector with warranty guaranteed and complete plans for building crystal radios only \$1.00 postpaid. Allen, 427-PM10, Clinton, Missouri.

**CRYSTAL** Radio experimenters. Write Leslie Hulet, R4, Lakewood, New Jersey.

**LIMITED** Quantity surplus double headphones. High quality, slightly used, \$7.95 value. Special now \$2.95 postpaid. Guaranteed. Allen, Dept. PM13, Clinton, Mo.

**COLOR Television!** Enjoy multi-color filter screen now. Easily attached. Send \$2 for your screen size. Satisfaction guaranteed. Dealers opportunity. Zingo Products, Johnstown 7, New York.

#### BUSINESS OPPORTUNITIES

**RAISE** Orchids—At home. Big profits. Fascinating. Year round any climate. No greenhouse. Instructions, including blooming-size orchid plant, sent for no-risk examination. Free details. Flowerland, 4622-DV, Wilshire, Los Angeles 3.

**BOOKKEEPERS**—Earn up to \$520 month serving small firms part or full time. Proved plan; simplified system. Particulars free. Tax Saver System, Dept. B, Fort Worth 2, Texas.

**SPARETIME** Home business sharpening lawnmowers brings \$100.00 monthly. Get business through hardware. No experience necessary. Send for free instruction book and business plan. Vernon P. Foley Company, Columbia Heights, Minnesota.

**BUILD** Luggage and cases at home. We sell your products. No special equipment needed. Free details. Cascraft, 805-A1 Sunset Blvd., Los Angeles.

**OPERATE** Escalator mailorder system, selling our products or any products. Fastest, most revolutionary mailorder system known. Write: Selbyco, Decatur 153, Ill.

**YOUR Own** business. Start now. Established sources, channels, contacts. Details. Woodward, 691A, Cambridge, New York.

**LEARN** Year round air conditioning. Write Don Gardner, 3119-A West Penn Street, Philadelphia 29, Penna.

**REAL** Butterflies and wings. Floral art decorative pictures. Mounted in wood picture frame, glass front, cotton background. Jos. Fleischman, 3201 Granada, Tampa, Florida.

**NEWEST** Spare, full-time home business, \$5 to \$10 hour possible. Paint with suede—The finish with touch and eye-appeal. Beautifully auto dashboards, signs, radios, toys, figurines, lamps—1000 others. Complete, step-by-step instructions sent for no-risk examination. Free details. Coast, 6004-JA So. Los Angeles St., Los Angeles 15.

**PROFITABLE** Enterprise. Work home. Free literature. Thomas Walker, 2048 Madeline Street, Oakland 2, California.

**OPERATE** Profitable mailorder letter shop. Write: Continental Publishers, 3332 So. 61st, Milwaukee 14, Wisconsin.

**START** Your own business on credit. Your own boss. 1658 of our dealers sold \$5,000 to \$27,500 in 1953. We supply stocks, equipment on credit. 200 home necessities. Sales experience unnecessary. Pleasant profitable business backed by world-wide industry. Write Rawleigh's, Dept. B-U-PPM, Freeport, Ill.

**IMPORT-Export!** Opportunity, profitable, world-wide, mail-order business from home. Without capital; or travel abroad. Established world trader ships instructions for no-risk examination. Experience unnecessary. Free details. Mellinger 709, Los Angeles 24.

**START** A buying service, buy wholesale thousands nationally advertised products. Make big profits selling at sizable discounts. Postcard brings details. American Buyers, 627-B Linden, Buffalo, N. Y.

**LIFETIME** Vitamin business! Terrific profits! Earn \$50 weekly spare time. National Health Products, Dept. MF, 150 Broadway, New York 38.

**MEXICO!** Curio wholesale! Excellent gift shop items! Illustrated pricelist 3c stamp. Filmer, 910 Marion, Pharr 10, Texas.

**TIN-Cans.** Turn them into cash. Nine methods. Instructions 50c. Charles Company, 12-DEN, Norwood, Ohio.

**START** Home mail order business, instructive booklet 25c. H. Sims, 222 26 Street, Cairo, Illinois.

**NEEDY** Money? Want independence? Be own boss. Start home mail order business on shoestring. Write: Cox, Saugus 10, Mass.

**\$26.500 SALES** in two weeks! Amazing radio-mail order method. Free details. Broadcast Service, 1413-J Great Northern Building, Chicago 4, Illinois.

**TO \$40.00 Weekly.** Sparetime, home operated mailorder business. Successful beginner's plan. Everything supplied. Lynn, 10420-M National, Los Angeles 34, Calif.

**SPARE** Time business. No investment. Details free. Howell, 1320 St. Andrew, New Orleans 13, La.

**SAWDUST.** Turn it into cash. Twenty methods, instructions 50c. Charles Company, 12-DBM, Norwood, Ohio.

**OWN** A garden golf business. Experience unnecessary. Brockway, Seaside, Oregon.

**MAIL** Order plan by manufacturer. Big profits. We deliver. Sibert Mo. Company, Newark 3, N. J.

**COPUBLISH** Mail Sale Advertiser, leading mail order paper. Details, latest copy, dime. Vancroy Shirk, Lebanon, Penna.

**SUCCESSFUL** Post card plans. Sell direct, get quick results, with small capital. Twelve plans, easily operated, suggested selling write-up with each item and where to obtain it. Free expert advice. Only \$1.00 refundable. Admit, Box 1188, Hollywood 28, Calif.

**MAKE** Perfume and other profitable products. Catalogue free. International, 8347 Tarnell-PM2, Chicago 21, Illinois.

**EARN** Money at home! Homemaker Magazine tells how. Sample 25c. Slesmore, Box 7, 4914 Kostner, Chicago 30.

**WHAT'S** Your field of interest? Whatever it is, specialized magazines will help you get ahead. Examine current copies of those covering your field through our easy-to-get-acquainted service. Choose from 4,367 covering all fields—Business, trades, agricultural, professions, insurance, real estate, music, educational, hobbies, sports, etc. Current list free. Commercial Engraving Publishing Company, 34C North Ritter, Indianapolis 19, Indiana.

**LEARN** Mailorder. Money-making opportunities. Work home. Literature free. Addison, 1840-K, Chicago 13.

**WANTED!** Home producers, by manufacturers in our clearing house service. Become a subcontractor, casting plastic products for these companies. Thousands of easy-to-make items required for consumer and industrial use. Cash in at home, without previous experience. Plastic Service Associates, Dept. 2-FM, East Boston 28, Mass.

**A BIG-Paying** business for a man in his 50's. One of our men makes \$11,000 in a year, other top men in their 50's earn up to \$5,000 to \$6,000 right from the start. We pay earnings in advance. Require no investment. Write confidential letter to Vice President, Dept. PM, Box 676, Dayton 1, Calif.

**EARN** Big money by mail. Depression-proof income. Circular 15 cents. Complete starting deal \$3.00 postpaid. Rebo, Box 21A, Whitsett, Penna.

**SEWING** Machine—Repair, sales, servicemen needed. Previous experience unnecessary. Operate home setup. Spare, full time. New zigzag machines, motors, parts, etc., supplied. Write today. Taylor Service Co., Hamilton PM-2, Ohio.

**IMPORT!** Export! Profitable details free. Warner's, Box 6, Ft. Scott, Kansas.

**RAISE** Canaries. Big profits. We instruct. Write Lackin, Broughton at Jefferson. Savannah 4, Ga.

**UNCLE Sam** tells how to finance your business. 15c. A-B Enterprises, Dept. P3, 8814 McMillan Ave., Silver Spring, Maryland.

**EXPORT** Business easy made! Substantial income from home. No merchandise buying. Full setup service, includes everything. Hermes Exports, 182 West 42, New York 18.

**DOLLARS** in personalized baby record books. Sell by mail. Eleven thousand new prospects daily. Use same literature we do. No-Cd-Rd, Oakland 6, California.

**BUSINESSMEN.** Industrialists, ask us about Florida. The State of Florida will welcome the chance to give you complete, dependable facts about Florida's many investment opportunities for business and large and small industry. Highly favorable tax situation. Write, telling about your interests and your specific requirements. You'll be put in touch with communities that offer what you want plus delightful year-round living. Write today: State of Florida, Industrial Development Division, 4314D Caldwell Building, Tallahassee, Fla.

**OPERATE** Profitable mail order business. Write Bryant, 5237 N.E. 22nd, Portland, Oregon.

**START** Home mailorder business. Details. Gedgard, Box 798-G, New York 1, N. Y.

**MAKE** Rubber stamps, repair dolls; learn silk screen printing; invisible re-weaving. Catalogue (\$60 ideas) free. Universal, Box 1070-A, Peoria, Ill.

**SCHERER** Magazine, Canfield 1, Ohio, monthly mailorder ideas, plans. Year \$1.00. Sample 20c.

**FREE** Details, "Your Own Mailorder Business." E. Merrill, Coldbrook Road, Bangor, Maine.

**ADVERTISING** Book matches—Cash in on big demand; sell union label matches. Cuts for all businesses and political parties. Free powerhouse selling kit, low prices, protection guaranteed on repeat orders. Cash commissions. Superior Match Co., Dept. MX-354, 7330 Greenwood, Chicago.

**EARTHWORM** Breeding! Built! Sell! Easy! Profitable! Get unusual story, "An Earthworm Turned His Life." Send dime. Earthmaster Systems, Dept. 14B, El Monte, Calif.

**ELECTROPLATE** Auto parts, novelties, mirrors, baby shoes, etc. Easy, inexpensive home processes. Free booklet. Tyro Metals, Box 13231-MM, Houston 19, Texas.

**SENSATIONAL** Money making opportunity. Biggest amazing you've ever seen. Agey, West Liberty, Iowa.

**MAKE** Money—Home, office, mailing magazines, etc. Samples, details 25c. Rorick, Box 30P, Cincinnati 26, Ohio.

**UNUSUAL** Opportunity. Sell by mail. Complete setups. Sherron, Box 343P, Bloomfield, New Jersey.

**45 PROFIT** From one bag of cement. McComb & Son, Hometown 1, Indiana.

**HOW** And where to obtain capital? Free details. Star Service, Wapakoneta, Ohio.

**SELL** Popular Mechanics and all other magazine subscriptions. Free catalog, supplies. Subscription Service Company, Dept. A, P.O. Box 2070, Birmingham, Ala.

**TREMENDOUS** Profit—Ornaments for dresses, coats, hats, easily made. Sell thousands for Easter. Start now! Sample kit 25c. Miles Crafts, 3220P Fish Avenue, New York 65, New York.

**NATURAL** Molding rubber, extra thick. Free sample. Flock, tinsel, candle wax. W. Wooley, 115-A Donald, Peoria, Ill.

**BEGINNING** Mail order? Essential information every beginner needs, including profitable plans. Details free. Edward Kleiser, 1535 Ardmore, Modesto, Calif.

**LIQUID** Rubber, make flexible molds. Free sample. Chaney, 1130 E. 16th St., Jacksonville 6, Fla.

**FREE** Wholesale catalog. Make up to 500%. Be your own boss, work full or spare time. Everyone a prospective customer. Sell costume jewelry, wrist watches, religious items, novelties, toys, gifts and prizes. Write today, specify catalog PM4, Health Distributing Company, 3253 Vineville Avenue, Milledge, Georgia.

**STRIKE** it rich in your own business. Full, spare time! Authentic new guide, gives concrete instructions; explains "Ways to Make Money, Have Happiness, Success!" Start with little, snowball to plenty, independence! This thrilling guide helps find your lifetime opportunity! Further details free! Wonderful Products, Box 3113-R, Santa Fe, N. M.

**FIBERGLAS**—Wonder material for boats, auto bodies, etc. New field opening. Earn while you learn. General practice kit and instruction manual \$5.00. United States Fiberglass-Resin Company, 722 East Washington, Los Angeles 21, Calif.

**HOW** And where to raise capital for your venture fast! 79 amazingly easy ways. Free details. Colburn, 486-P South Wilcox, Beverly Hills, Calif.

**\$10.00 HOURLY** Possible making ladies' jewelry. Book shows how. Send \$2.00. Jewelfcraft, Wrenona, Illinois.

**MAKE** Money by mail order. Free catalogue shows how. Details free. Opportunities Unlimited, Dept. 6, Box 1576, Boston, Mass.

**MAKE** Perfumes, other products at home. Write Carey, 1914-PM2 Chouteau, St. Louis 3, Mo.

**EXCLUSIVE** Chemist—developed formulas for modern manufacturing success. Literature free. Millar, Chemist, Tampa, Florida.

**OPERATE** Fascinating mailorder book business. Easy. Profitable. Instructions 25c. Falcon House, Winnipeg 2, Ill.

**BECOME** A distributor. Profitable occupation. Our instructions, information tells how. 25c. Davis Research Publications, 1028 Gault, NE, Knoxville 17, Tennessee.

**UNUSUAL** Homework opportunity, spinning Angora spawlines for us. Men, women. Angora House, PM, Springfield, Illinois.

**MAILORDER** And advertising instructions. Two books—\$2.00. Third book free. Lochner's, Box 2428, Greensboro, N. C.

**PLASTERCRAFT** Molds, liquid rubber, plasters, flocks, candle supplies. Catalog and manual free. Blue Rapids Supply, Blue Rapids, Kansas.

**PLUNGING** Into small business? We did! Free outline pitfalls to watch. Taylors, Box 208-M, Three Lakes, Wisconsin.

**EARN** Money! Amazing plans! Easily mastered. Details. Bruns, 216-B West Jackson, Chicago 6, Illinois.

**NEED** Capital? I'll tell you how and where to get it. Write. Dougherty, Box 88-J, Van Nuys, Calif.

**BUY** Wholesale! Appliances, watches, gifts. Catalog \$1.00 (refundable). Buda, Box 124, Conida, N. Y.

**MAILORDER** Bulletin service. Expert working plan, opportunity catalog, 25c. Tunnel's, Cory, Penna.

**NEW** Kind mail order—No investment for merchandise, advertising. Start on shoestring. Eastern, Box 142L, Dorchester 24, Mass.

**EARN** \$2.00 Hour! I do, making sandals. Young's, 1308-P31, South First, Arcadia, California.

**NOTARY** Public commands more money. Be one. Stationers, Helotes, Texas.

**START** Venetian blind laundry. Profitable lifetime business. New machine. Free booklet. F. G. Co., 442 N. Seneca, Wichita 13, Kansas.

**A Business** of your own financed entirely by mail. Can be started during spare time. McCann, 1613 Johnson, Amarillo, Texas.

**MOLD** Making liquid rubber; quarter pint sample with instructions, \$1.00 postpaid. Plastercraft Supply Company, 2053 St. Clair Ave., Cleveland 14, Ohio.

**LEARN** Metalizing baby shoes, gifts, etc. Bronze, gold, silver. Polio free. Kikkavi, 7217-MK South Broadway, Los Angeles 3.

**FREE!** "301 Profitable Small Businesses!" Amazing shoestring plans! Work home! Start apartment Detachment Surveys. Kenmore 28-R, N. Y.

**LATEX** For molds. Free instructions casting statuary, novelties. Major Chemical, 23 Allerton St., Boston 19, Mass.

**FREE** Vending machines; if used to sell our profitable nuts. Continental, Box 1361-A, Milwaukee 1, Wisconsin.

**BIG** Money. Amazing new home business. Pearl finish baby shoes. Free plan. Pearl Art, 7216 Bear, Bell 1, Calif.

**OROW** Mushrooms. Cellar, shed, and outdoors. Spare, full time, year round. We pay \$3.50 lb. We paid Habbit 44,185.00 in few weeks. Free book. Washington Mushroom Ind., Dept. 172, 2954 Admiral Way, Seattle, Washington.

**COLOR** Concrete with chemicals. Marble-glass cement benches, pottery, garden ornaments. Home—shop. 10¢ brings sample, pictures. Hollywood Cementcraft, 8327-JR Wonderland, Hollywood 46, Calif.

**MAKE** Them! Eat them! Sell them! Pralines, the good Southern pecan candy. Details free! A. Dadson, 4815 Bellnote Drive, Houston, Texas.

**HOMEWORKERS** wanted: Mailing publications. Sample, details and big instructive manual only 25c. Dispensa, 2920 Harbor Ave., Ashabula, Ohio.

**NEW** Plastic mending tape. Just press on! Repairs clothing instantly. Lighting seller. Samples sent on trial. Kristen, 100, Akron, Ohio.

**EARN** Money with typewriter, sewing machine! Details free. Edwards, 3915-PM, 12th, Des Moines 13, Iowa.

**WE** Love our mailman—He leaves over \$1,000.00 monthly in our rural mailbox. My college professor husband drafted a scientific home mailorder method. We bought a Texas ranch, live as we always wanted. Now we sell the Ranch Mailorder Method. Operates anywhere. Inquire: Evenhushado Ranch, Helotes, Texas.

**MAKE** Money at home as renewal headquarters for all magazines. Liberal commissions. No experience—No capital needed. Supplies furnished. Write for free catalog. McGregor Magazine Agency, Dept. 500 B, Mount Morris, Ill.

**POPCORN** And potato chip equipment. Leco, Box 933-A, Springfield, Ohio.

**MAILORDER**—Operate profitable home business using free advertising method reaching millions. Revealing information free. H. P. Beidel, 7070 Hollywood Blvd., Hollywood 28, California.

**MEN Women!** Make money at home or build your own mailorder business spare time. Free booklet reveals secrets. Write: Spandoo Surveys, 413 Portland, Rochester 5, New York.

**CO-PUBLISH** Interesting mailorder publications. Two samples, literature, full details, 25c. McAlister Publications, 3464 Farmville, Memphis 13, Tenn.

**BUY Wholesale** thousands items. Lists free. Cottage Industries, Omaha 13, Neb.

**MAKE Money** from old coat hangers. \$1.00. Baxter, 4972 San Rafael, Compton, Calif.

**YOUR Ideas** should pay. Let us manufacture and market your pet gadget for you. Ideal Machine and Tool, 4114 Olive, St. Louis 8, Mo.

**SAVE Money** when you buy home or farm. Priceless information, only \$1. W. Wells, 323E 5th, Escondido, Calif.

**START Sparetime** home mailorder business. Pays big profits. Amazing instructional book, 25c. Moneyback guarantee. Tondra Service, 568 Ocean, Portland 3, Maine.

**BUY It wholesale!** Manufacturers, distributors offer \$50,000 items. Literature free. Olsen, 1291-A East Third St., Duluth 5, Minn.

**BOOKKEEPERS.** Increase earnings operating sensational bookkeeping service. Kern, 4942 Vineland, North Hollywood, Calif.

**46 FROM** Square foot plywood; saw necessary. Write: Woodarts, Bridgewater, Mass.

**65.00 MONTH Up.** Establish a permanent California address for your mail order business here in downtown Los Angeles. Confidential. Replies forwarded immediately and efficiently. Established here 10 years. Ellery Office Service, 1244 S. Grand Ave., Los Angeles 15, Calif.

**WORK At home.** Mail to automobile owners. Big earnings. Everything furnished. Eastern, Box 142-F, Dorchester 24, Mass.

**FREE Folder.** Make big money by mail the sure way that pays. New, different. Fullmer, 92H Greenwood, Pocatello, Idaho.

**MAKE Money** selling by mail; instructive booklet 25c. Manhattan House, P.O. Box 31-M, Saint Albans 12, N. Y.

**25 WEEKLY Working** two hours daily at home. Lyke, Box 2471-A, Cleveland 12, Ohio.

**START Your own profitable** home mailorder business! We supply everything! Write today! Studio Products, Box 564-A, Glendale 5, Calif.

**WHOLESALES** Of sensational nationally advertised appliances, silverware, watches, cameras, etc. Start your own business. Full details. Send 50c for catalog. International Sales Co., 175 Fifth Ave., New York 10, N. Y.

**LIVING Miniature ("Ming") trees** only 10 to 30 inches tall. Grow at home. Big profit! Spare time opportunity. Fascinating! Amazing! Write for free seed and plan. National Nursery, Dept. FC, Inglewood 4, California.

**BREED Rare tropical fish** at home. Earn big money! Learn secrets! Help fill huge demand. Amazing opportunity! Free plan. Tropicals, 1008-F Los Angeles St., Los Angeles 15.

**INCOME** From local information. No selling. Write Nehéro, La Verne, Calif.

**RESILVERING Mirrors,** formula 50c; two-way looking mirrors, (No one sees you), 50c; coppered mirrors, 50c. All \$1.00. Nelko-Mir. Box 3462-J, Chicago 54.

**START Home manufacturing business.** Make cleaners, soaps, polishes, cosmetics. Free literature, Kennz, Park Ridge, Ill.

**MAKE Money** spare or full time, casting metal toys and novelties. Big wholesale and chain store demand for autos, soldiers, ashtrays, banks, etc., keeps manufacturers busy. Production moulds furnished for up to 100 and more castings per hour. No experience or special place necessary. Write for information and illustrations of patterns needed. Metal Cast Products Co., Dept. A, 1696 Boston Road, New York 60, N. Y.

**MAKE Flexible molds!** Cast plaques, bookends, figurines! Free sample! H. Tooker, 630-R Chestnut, Hamilton, Ohio.

**NEW Exceptionally profitable plans,** ideas for home operated mail business. Rush name. Miller 1773-P Carlson Road, East Cleveland 12, Ohio.

**RECAST** Old batteries into new. Latest achievements. Battery Laboratories, Minneapolis.

**GOOD Paying business** silvering mirrors, plating auto parts, reflectors, bicycles, bathroom fixtures, etc., by late method. No tanks or shop required. Outfit furnished. Free booklet. Gunmetal Co., Ave. H. Decatur, Illinois.

**BUY Wholesale.** Thousands articles. Supply directory, 10c. Idealco, Park Ridge, Illinois.

**EXTRA Money—No selling, operate** vendors. Amazing profits, details free. Silver King, Suite 229, 822 Diversey, Chicago 14.

**OPERATE Profitable** mail order business. Write Walter Service, 4159-A East 112th, Cleveland 3, Ohio.

**MINK Raising information** free. Complete. Lake Superior Mink Farm, Superior, Eel, Wisconsin.

**COLORGLAZED Concrete pottery** made without molds. Patented method. Cemetery products, novelties, tiles. Basement leak-sealing. Money-making projects. Booklet, details free. Men only. National Pottery Co., Grand Rapids, Michigan.

**FREE Book "505 Odd, Successful Business"** Work home. Expect something odd! Pacific, Oceanside, Calif.

**137 PLANS** For starting home business. Details: Ethic Co., 220 Grand St., New York 13.

**FIX Typewriters.** Free booklet describes our modern, inexpensive home-study course. Factory methods taught. Write Typewriter, Building 1, Tarentum, Penna.

**MONEY** in new greaseless doughnuts. Start in kitchen. No smoke. Sell stores. Free recipes. M. Ray Company, 3500 South 15th Ave., Minneapolis 1, Minn.

**START A** lettershop on a shoestring! Sales \$50,000. Started \$39.00. Information? Merritt, Box 13, Basking Ridge, N. J.

**VENDING Machines—No selling.** Operate a route of coin machines and earn amazing profits. 32-page catalog free. Parkway Machine Corporation, Dept. 72, 715 Ensor St., Baltimore 2, Md.

**HAVE Home** mail business—Get \$10 orders in every mail. Keep \$8.00. Everything furnished. Hutchinson, 401-A Adams, Dorchester 22, Mass.

**BOOKKEEPERS,** Keep books, small firms spare time. Manual latest technique by C.P.A., \$3.00. Modern Business, Box 409, Youngstown 1, Ohio.

**BRONZED** Baby shoe supplies, instructions, mountings. Metal bookends, \$1.50 pair. Free catalog. National Bronze Supply, Box 56, Los Angeles 12, Calif.

**PERFUMERS;** Cut costs. 500 fragrances. supplies. Box 3767, San Diego, Calif.

**QUICK Money!** Repairing car batteries. At home! Easy, too! Batterymah, Grand Junction, Colorado.

### MONEYMAKING OPPORTUNITIES

**BEGINNERS:** Proven money making method for limited capital. Don't get wrong start with home business. Write Traylor Enterprises, Box 2838, La Feria, Texas.

**AM** interested in buying profitable mail order business. Write Paul Harris, 3041 West Madison Street, Chicago, Illinois.

**"HOW To Make Money With Simple Cartoons"**—A book everyone who likes to draw should have. It is free; no obligation. Simply address Cartoonists' Exchange, Dept. 92CM, Pleasant Hill, Ohio.

**"MONEYMAKING By Mail"** treatise sent free to first 1000 writers. Vinaco Associates, Trenton, N. J.

**OPERATE Profitable** mail order business, for details write E. J. Bode, 223 So. Jefferson, Canonsburg, Penna.

**COST** Of things selling up faster than your income? You can make more full or part time as a Rowleah dealer. Write for full particulars. Rowleah's, Dept. B-RR-PPM, Freeport, Ill.

**START A** buying service, buy wholesale thousands nationally advertised products. Make big profits selling at sizable discounts. Postcard brings details. American Buyers, 630-R Linden, Buffalo, N. Y.

**OPERATE Cafe, diner,** without penny invested. Will help you locate. Free details. Restaurant Arts, 52-B, Fremont, Ohio.

**\$10,800 PROFITS!** Your own mailorder business! No risk! Success plan free! Treasury, 709 Webster, New Rochelle, Pa-20, N. Y.

**MINIATURE Trees.** Why pay \$2.00, \$5.00 for growing secrets? Free details. Bassett, Dept. R, 5038 N. Winthrop, Chicago 40.

**BUY Wholesale.** Thousands nationally advertised items. Save, make money! Free details. Durax Co., Box 672-R, Chicago 90, Ill.

**CASH In.** Get into mail order business. 88 page book reveals business secrets, effective advertising, what to sell, business advice. Numerous tested and original money-making plans. Over 40,000 words. We'll include other helpful literature free. Rush 25c to: Par Products, 2185 Bolton St., New York 62, N. Y.

**TYPEWRITER Owners.** Make handsome profits. Get details today. Groves Company, 882, Hastings 6, Nebraska.

**CREATE A** life-time income, if you are home owner. No cash needed. No personal work involved. See picture Home-A-Minute kit display ad this issue. Handbook tells you how. Price \$2.95 pzd. Free literature. R. J. Hall & Co., Dept. B, 3324 W. Roosevelt Dr., Milwaukee 16, Wis.

**EARN Money** evenings, copying and duplicating comic cartoons for advertisers. Adservice, Argyle 1, Wisconsin.

**OWN, Operate,** route washing wells. Place these new \$8.50 skill games on counters in cafes, luncheonettes, clubs, etc., collect coins weekly. Write, Legal-chair, Box 328, Long Beach 1, Calif.

**BWARE** Of business boobytraps! One misstep can break you. 6 practical lessons in small business management by mail, \$2.00 each lesson. Pay each lesson separately. Quit anytime. 20 years auditor and business advisor. Simple language. Copyrighted text distributed nationally. Send \$2.00 first lesson. Refund guaranteed if material returned in 5 days. Don't wait to learn by experience. Act now! Wm. Groznick, 315 State St., Springfield, Mass.

**TOP Men** earn \$1,000 and more in a year in a profitable selling career. Call on owners and users of heavy duty equipment. Moly lubricants and other top quality specialized products provide repeat business regularly. Top earnings immediately. No collection or delivery worries. Write E. J. Baker, Dept. 749, Box 676, Dayton, Ohio.

**BECOME** Notary public with seal, etc. Write Daniel Hughes, 6327 South Aberdeen, Chicago, Illinois.

**SIDELINE Salesmen** wanted. Write Ideaco, 4675 W. Virginia, Denver 19, Colo.

**285 WAYS** To make money at home, information free. Write, Box 597-2, North Hollywood, California.

**GET Cash** for box tops, wrappers, labels, etc. Information, list 25c. Oblson's 1, McClave, Colorado.

**PRINTING** And office supplies wholesale. 10,000 items. Literature free. Royal, Box 268-A, Cleveland 27, Ohio.

**DON'T** Be Mr. Average Man. Operate your own business. Very desirable, non-perishable, no chemicals or liquids, highly profitable. Write for details. Protecto Products Company, Box #543, Oak Park, Illinois.

**BE** Appointed, Outfitted, Notary public. Thousands needed. Men. Women. World's lowest cost. Box 3025, Dallas 1, Texas.

**LESS** Than \$50.00 starts you in profitable ornamental iron railing business. Instructions \$1.00. Bafro, Box 45, Fond du Lac, Wis.

**FREE!** Complete mailorder business! Terrific profits! No investment! VILAMING, 2910PM Beverly Boulevard, Los Angeles 67.

**MAKE** And sell rose scented beads. Formula and complete instructions 10c. Dennis, 1402 Kearny, #4, San Francisco, Calif.

**FLEXIBLE** Rubber moulds for plaster and Marble figurines. Sample and large illustrated catalog 25c, refunded on first order. K-C Novelties, Dept. 4, Easthampton, Mass.

**FREE!** "201 Profitable Small Businesses" Amazing shoestring plans! Work home! Start sparetime! Decumant Surveys, Kenmore 23-R, N. Y.

**NOW:** Take your choice of the best money making opportunities in America. We'll recommend your name to each advertiser listed under "Business Opportunities"—"Profitable Occupations" and "Money Making Opportunities"—in this and dozens of other magazines. We'll also send details and positive proof of how we, and others scattered about country, operate local sparetime typing business with good guaranteed income. All above \$1. Newsletter, Oxford, Wisconsin.

**400 RADIO Stations active.** Free radio advertising. Pay commission only on orders received. Free information. Mishak, 1, Wasco, Miss.

**NEED Money? Make \$100 weekly** at home in business of your own. 10c rushes details. Miller, 9643 Julia Ave., Downey 1, Calif.

**GROW Mushrooms.** Cellar, shed, and outdoors. Spare, full time, year round. We pay \$3.50 lb. We paid Babbitt \$4,165.00 in few weeks. Free book. Washington Mushroom Ind., Dept. 173, 2954 Admiral Way, Seattle, Washington.

**SELL Stamps.** I guarantee profit. Return envelope. Fairbrock, 13321 Blossom, Flushing, N. Y.

**CHINCHILLAS:** Profitable. Raise in spare room, cellar. Moss Chinchilla Ranch, 796 Rincon, El Sobrante 11, California.

**EARN \$50 Weekly** operating home mail business. Write, Lewis Bartlett, Highland, Georgia.

**1000 DEPRESSION Fored me** to invent my own business—A minimum-cost, high-potential home mailorder. Lucky design paid immediately over \$1,000 every month since! Over half sell! This original design, "Selective Mailorder," is United States Postal Service approved. Now mapped out to guide mailorder beginners. Literature free. Eveningshade Ranch, Bentons 14, Texas.

**SPARETIME Profits** taking subscriptions, all magazines. Wholesale catalog free. Cassell Agency, Westfield 2, New Jersey.

**EARN \$50.00 Daily** making mats, shoes and mud guards from old tires. 8 and 6 Patents Inc., 1367 North Clark St., Chicago 10, Ill.

**SELL Tiansia gems;** \$9.35 carat wholesale. More brilliant than diamonds. Free catalogue. Diamondite, 1404-M Mitchell, Oakland 1, California.

**30,000 ARTICLES Wholesale.** Source directory, dime. Nelko, Box 3482-DK, Chicago 64.

**SCHOOL Seniors—Sell** classmates America's most beautiful graduation name cards. Largest selection. Highest commission. Outsell all others. Free sample kit. Printcraft, Dept. M, 1509 Maple Street, Brenton 5, Penna.

**READ Progressive Mailtrade,** the magazine that tells how to make money by mail. Dime brings sample and special offer. Progressive Mailtrade, Box 347, Sheboygan, Wisconsin.

**FREE Book "505 Odd, Successful Businesses!"** Work home. Expect something odd! Pacific, OceanSide, Calif.

**137 PLANS** To make money, local mail-order. Details: Elite Co., 290 Grand St., New York 13.

**PUBLISH Your own magazine.** Hand-some 62 page format, well edited, illustrated. Cost low as \$1.00 month. Brings you prestige, profits. 25c brings sample. Details: National, Ord. Nebr.

**MAKE Money** at home by mail. Fast, easy. Liebig Industries, Beaver Dam 4, Wisconsin.

**FOREIGN Employment** construction work. If interested in foreign projects with high pay write Foreign Service Bureau, (Dept. P.M.), Metuchen, New Jersey.

**GENERAL Contest Bulletin.** Issued monthly. Sample, 10c. 18991 1/2 East 5th, Duluth, Minn.

**MAKE To \$4.50** hour doing common pen lettering. National Artists, 4011/2-A North Marsalis, Dallas 3, Texas.

**MAKE Money** at home. It's easy. I'll show you how and help you. Write: Allen, Box 4A, Houma, Louisiana.

**WINNING Prize** contests is fabulous, confidential, home opportunity! Send stamp National Contest Bulletin, Box 2885-P, Miami 18, Florida.

**BE The Popular Mechanics** representative in your neighborhood and earn big profits in your spare time. Write Popular Mechanics Magazine, Room 403M, 208 E. Ontario St., Chicago, Ill.

## FORMULAS, PLANS, ETC.

**ANY Formula \$5.00.** Satisfaction guaranteed. Jack, Consulting Chemist, 5133 Gairow, Philadelphia 31.

**PRODUCT Analysis,** manufacturing formulas, processes developed. Moderate fees. Plastics, Box 1574, Boston 4, Mass.

**MILLER'S Modern** manufacturing formulas make fast-selling products that get the business and pay! Fifty years supplying the best. Late literature free! Liscombe Miller, Chemist, Tampa, Florida.

**OUR Laboratory** tested formulas and know-how put you in business. Free information. Write Stark Co., Grafdon 2, Wis.

**500 MONEY Making formulas.** 25c post-paid. Allen, Dept. PMC, Clinton, Missouri.

**FORMULAS; All kinds.** Latest, best. Literature free. Kemikal, Park Ridge, Ill.

**GENUINE Manufacturing formulas.** Latest. Literature free. Nelko, 3482-P Merchandise Mart, Chicago 34.

**REAL Manufacturing formulas.** Lists free. Cummings, Chemist, Gordon Ave., Syracuse 4, N. Y.

**ANY Formula \$5.00.** Chemical Instruction Sheet—catalog 10c. J. Belfort, 216 W. Jackson, Chicago 5.

**FREE Formula catalog.** Anything analyzed \$15. Western Chemical, Salem, Ore.

**LABORATORY Tested formulas.** Catalog free. Post Chemical Company, Terre Haute 2, Indiana.

## PLASTICS

**PLASTICS Home-craft** course for men and women. Tells and shows how to make hundreds of fast selling plastic products. All plastics and materials for 23 projects included in course. No special tools needed. Course pays for itself. Write for free booklet. Interstate Training Service, Dept. D-3-B Portland 13, Oregon.

**NEW Liquid casting plastic.** Clear, colors. Preserve flowers, insects, photos permanently. Saw, drill, carve. Send 25c for Castable Casting Manual and proved success plan showing how to make money at home. Custolite, Dept. B-101, Woodstock, Illinois.

**FIBERGLAS, Polyester, Plexiglas, Acetate, Vinylite.** Casting, coating plastics. Maurice Lannon's Fiberglas "How" book now ready. \$2.50. Fast service, best price. Catalog 10c. Airmolded 35c. Gem-O-Lite, Box 6867P, North Hollywood, California.

**PLEXIGLAS Sheets—Cut to size.** Clear. All thicknesses. Standard outdoor translucent colors. McClarin Plastics, P.O. Box 158H, Hanover, Penna.

**PLASTICS, Cements, dyes, findings, carvings.** Wholesale prices. 64 page catalog free "Trace and Carve" pattern book for carving and coloring fish, birds, animals, only 35c. Taylor & Art, Inc., 1710 East 12th Street, Oakland 6, California.

**LEARN Plastics** at home. Complete kit—\$5.98 postpaid. Dime brings sample plastic, three experiments, full details. Plastic Projects, Box 5151, Detroit 35, Mich.

**PLASTIC, Sheets, rods, tubes, etc.** Free list. Plastic Supply Co., 3901 N. Grand Blvd., St. Louis 7, Mo.

**PLEXIGLAS, Lucite.** Any size sheets. Square foot (12 x 12) cost, 1/16" \$1.18; 1/8" \$1.59; 3/16" \$2.00; 1/4" \$2.25. Add 15c for postage. Minimum order \$3.00. Almac Plastics, 800 Broadway, New York City.

## CHEMISTRY

**IMPROVED Second printing.** "Spectacular Chemical Experiments" manual. Not mimeographed. Contains complete formulas, set-ups, instructions, special data, on thermite, fulminates, acetylides, explosive powders, etc. Only \$1.00 postpaid. Concise yet thorough. Chemi-Technis Laboratories, 584CP Elms, Buffalo 3, New York.

**AMAZING New book** of science. Experiments, formulas and catalogue of laboratory supplies. Only 25c. National Scientific Co., Dept. 16, 2804 W. North Ave., Chicago 47, Illinois.

**CATALOG, Bargain lists, 20c.** Laboratory Sales Co., Box 181-A, Brighton, Mass.

**SPECTROSCOPE** For quick chemical analysis \$3.00. Knitting Sons, Los Altos, Calif.

**ILLUSTRATED Catalog:** Chemistry, mineralogy, biology 26c. Tracey Laboratories, Evanston, Illinois.

**DO Your own vitamins, mineral, chemical analysis** with laboratory analytical ion exchange column. Complete apparatus with cation, anion resins, instructions. \$4. Rainway Chemical Company, 300 Delaware, Berkeley, California.

**NEW Idea chemical** and apparatus outfit for home experimenting. Photo-plates, microscopes, chemicals, biological and laboratory supplies in small quantities. Catalog 25c. Established 1931. John H. Wang, 124A West 23rd Street, New York, N. Y.

**CHEMICALS** And apparatus for industrial, analytical, and private laboratories. Catalog 25c. Dept. M-58, Biological Supply Co., 1176 Mt. Hope Ave., Rochester 20, N. Y.

## AGENTS WANTED

**JUST Out!** New thrilling sensation in everyday cards. Rich foils, satins, velours sell on sight, 21 for \$1. Make up to 100% profit. 50 assortments, name-impriated stationery and napkins, gift items. Several \$1 assortments on approval. Imprints free! Joy Greetings, 507 N. Cardinal, Dept. 608, St. Louis, Mo.

**A Dress-lingerie** shop in your home. No investment. Good commissions. Write for sample book. Modern Manner, 286PA Fifth Avenue, New York.

**BALL Pens \$10.00 gross,** d.e.s.c. blades \$4.75M, novelty flashlights with batteries \$3.25 dozen, assorted ruffled plastic aprons \$1.40 dozen up, needlebooks with threads \$8.25 gross. Lutsker, 871P East 170th, New York City 59.

**MAKE Money** introducing world's cutest children's dresses. Big selection, adorable styles. Low prices. Complete display free. Rush name. Harford, Dept. L-3341, Cincinnati 25, Ohio.

**GOLD Or silver letters, numbers.** Windows, doors, trucks, 1" to 6", 500% profits. Free samples. Atlas-T, 544 West 78th, Chicago 20.

**AT Last! Something** new and sensational in everyday cards, 21 for \$1. Make extra money fast! Show satin, velour, metallic cards. Get orders easy. Big line \$1 assortments, scented stationery, personalized napkins, gift items. Imprints free. Several \$1 boxes on approval. Pure Co., 2801 Locust, Dept. 440-B, St. Louis 3, Mo.

**MANUFACTURER** Of 16 guaranteed household and electric products. \$1 to \$15 offers big profit deal. Sibert Company, Newark 3, N. J.

**BEAUTIFUL Feather** pictures, 200% profit! Free sample. Apartado 9036, Mexico L. D. P.

**BUY Wholesale** thousands nationally advertised products at big discount. Free "wholesale plan." American Buyers, 629-R Linden, Buffalo, N. Y.

**SUPER 120% Profit.** 500 name and address labels, 40c your cost. Free selling kit with sample order. Bruce Services, Box 71-AE, Boston 1, Massachusetts.

**MAN Wanted—Are you** dissatisfied with your work? Would you like a business of your own? If so, write Rawleigh's, Dept. B-00-PPM, Procpot, Ill.

**FREE:** "How to Make Money with Greeting Cards" booklet. Samples on approval. Organizations! Ask for fund-raising plan. Writewell, PM-42, Boston 16, Mass.

**SPARE Time money** plus new car as encouragement bonus. Amazing 80 gauge nylon 2 pairs guaranteed 3 months. Write Wilkint, 1719 Washington, Greenfield, Ohio.

**EARN \$50 Weekly** spare time selling vitamins! Dept. MF, Emm-Bee, Box 992, New York 8.

**BUY Wholesale, 25,000 items.** Catalogue 25c. Matthews, 1472-B5 Broadway, New York City 28.

**SELL New automatic** floor waxer. Trigger on handle, Retail \$3.99. Your profit 125%. Write Smith, Inc., Greenfield 18, Mass.

**NEW Sponge** wall cleaner. Erases dirt like magic. Wallpaper, painted walls, ceilings. Saves redecorating. Lightning seller. Samples sent on trial. Kristee 53, Akron, Ohio.

**CLEANS Windows** without mess. Strange dry cleaning cloth. Replaces liquids. Windows gleam. Samples sent on trial. Kristee 53, Akron, Ohio.

**UP To \$10 per hour.** Full or part time, selling Ortho-Vent Spring-Step cushion shoes. High commissions, cash bonuses and exclusive repeats build your profitable business guaranteeing security. Free sales kit. No experience or investment needed. Write now: Ortho-Vent Shoe Company, Inc., Dept. PM-24, Salem, Va.

**RUN A spare-time greeting card and gift shop at home.** Show friends samples of our new 1934 all-occasion greeting cards and gifts. Take their orders and earn up to 100% profit. No experience necessary. Costs nothing to try. Write today for samples on approval. Regal Greetings, Dept. 95, Ferndale, Michigan.

**MEXICAN Feather Pictures.** High profits! Fast sellers! Adelphi, Box 57-B, Bellefonte 26, N. Y.

**BIG Money selling waitresses, beauticians, others.** guaranteed uniforms \$1.98 up. Nylons, cottons. Sizes 9-52. Free bonus uniforms. Full, part time. Experience unnecessary. Free full color catalog. Upland Uniforms, 308 East 23rd, Dept. G-7, N. Y.

**AGENTS—Show America's leading nationally advertised line.** Novelties, gifts, utility items. 100% profits. Prospects everywhere. Steady repeats. Write today for sensational low prices, free literature. Charms & Cain, 407-PM-24 South Dearborn, Chicago, Ill.

**EXTRA Money every week.** I'll send you full-size Blair household products. Show them to friends and neighbors. You can make big extra profits. Write Blair, Dept. 31MB, Lynchburg, Va.

**SELL Our personalized stationery, wedding announcements.** Details, Mercury Press, Box 66M, Marengo, Iowa.

**CALIFORNIA Sweet smelling beads.** Sensational sellers. Free particulars. Mission, 2326PM West Pico, Los Angeles 5, Calif.

**VOLUME Sales.** Power mowers, Chain saws. Prepaid. Terms, Farmco-PM, Excelsior Springs, Mo.

**BUY Wholesale from nationally advertised manufacturers, distributors.** Literature free. Carter Publications, Box 6011-D, Chicago 80.

**OWN A business!** Private labels! Exclusive sales! We supply product, plan, literature; you furnish management, employ salesmen, get terrific over-ride profits just for being boss. Details free. VitaMina, 2903PMA Beverly Boulevard, Los Angeles 57.

**EARN \$100 Up weekly** with the New Charm underarm and personal hygiene deodorant. Nothing else like it. Fast seller, steady repeater. Write today for free special starting offer. Charm Products, 5345 S. Wentworth Ave., Chicago.

**RID-O-Waste.** A necessity for septic tanks, cesspools and outdoor toilets. Double your money. Details and sample 75c. Rid-O-Waste, Meredith, N. H.

**BARAINS.** Job lots, close-outs! Save up to 50% on clothing, hosiery, notions, drugs, toiletries, gifts, jewelry, television, etc. 2000 items. 25c brings wholesale bargain catalog with special get acquainted offer which includes free \$1.00 merchandise certificate. Reliable Jobbers, 311-D North Desplaines, Chicago.

**BIG Profits selling ties** (\$2.00 values), \$1.50 dozen. Free catalog, Empire Gravels, 611A Broadway, New York 13.

**EASY Handwork makes fast-selling useful articles.** Sample free. Sunmade Company, Brockton 84, Massachusetts.

**REPRESENT The new Ar-Lee Gem,** retractable ball pen. Top quality, firm imprints. High commissions. Send two dollars. Sales kit. Refundable first order. Ar-Lee Imprints, 575 East 51st St., Brooklyn 3, N. Y.

**UNUSUAL Invention.** Earn \$500 month up. Full or part time. National company. Automatic fire extinguisher. Big rural market. \$11 sale earns you \$8. Free outfit. Write Superior Products Inc., Dept. 178, 3410 Main St., Kansas City, Mo.

**MEN, Women, sell Glamour Garment Hangers** to friends. Free sample. Big profits, repeats. Westerland, Box 114, Babylon, N. Y.

**EASY Extra income — Sell sensational new search resistant silicone ironing board covers.** Good Housekeeping approved. Terrific \$1.98 sellert. Send for free complete selling kit. Menell Products, Dept. P—P.O. Box 431, Midtown Station, New York 18, N. Y.

**FREE Hosiery!** Sensational new way earn to \$2 hour in spare time! Introduce amazing hosiery by giving away free pairs to every man and woman (regardless whether or not final purchase is made) just to prove how good they are! Wonderful luxurious nylon stockings, guaranteed against runs and snags, nationally known, sold coast to coast. New miracle one size two-way stretch men's nylon hose, contains no elastic, yet fits every size foot from 8 to 14! Never sag or droops, clings to foot like second skin. Outlasts several pairs ordinary hose and guaranteed one full year! Money or experience unnecessary. Buy nothing. Deliver nothing. Advance cash plus huge cash bonus to 40%. Your own hose as extra bonus. Special manager plan so you can appoint agents. Nothing like this ever offered before. Samples of stockings and miracle socks with complete money-making outfit free and prepaid. Nothing to pay now or later. Absolutely no obligation. Simply mail postcard with your name and address. Kender, Babylon 13, N. Y.

**APPLIANCES.** Cameras, radios, toys, typewriters, watches. Large coded wholesale catalogue! Cam Company, 6806PM—20th Ave., Brooklyn 4, N. Y.

**MAKE Up to 150% profit selling finest line everyday greeting cards.** New \$1.00 assortments, 21-card boxes, make-it-yourself kits, 100 fast-sellers. Extra gift bonuses! Assortments on approval. Stationery samples free! Creative Cards, 2305 Cermak, Dept. 562-H, Chicago 8.

**PRINTING.** Salesbooks, envelopes. Free illustrated catalog. Erco, Dept. PM, Bronx 72, N. Y.

**BE A money maker.** Use your home as magazine headquarters. Liberal commissions. No experience—No capital needed. Everything furnished. Write for free catalog. McGregor Magazine Agency, Dept. 500 A, Mount Morris, Ill.

**JAPAN Trade directory, 1934, 400 pages,** \$3.00 prepaid. Hoffman, 284P Madison, Passaic, N. J.

**BEST Source for Nylons.** Rich Supply, 215 W. 96th, New York 25.

**SAVE 50-75% On household appliances.** Free particulars. Wholesale catalog. Nuebling-P, Sicklerville, N. J.

**SELL: Watches, jewelry, household, gift items, national named brands.** Guaranteed. Illustrated catalog and confidential wholesale price list 25c, refundable. H. Distributors, Palatine 5, Ill.

**SCHOOL Sellers—Have fun and spending money!** Be popular with your classmates. Send postal for details. Craftcards, Box 235-L, Pittsburgh 18, Penna.

**TWO In one screwdriver.** Money maker. Sample 25c. Ideal Service, 4844 Geary, San Francisco 18, California.

**WINDOW Sign letters.** Samples free. West Coast Sign Letter Service, P.O. Box 697, Escalon, Calif.

**MAKE Extra money.** Sell front door name plates to friends, neighbors. Retail \$1.98; you make \$1.00! Free selling kit. Modern Engraving Co., P.O. Box 194, Boston 14, Mass.

**YOUR Own business—Used suits \$1.50,** overcoats 55c, machines 15c, shoes 12½c, ladies coats 30c, dresses 15c. Enormous profits. Catalog free. Mara, 558-AA Roosevelt, Chicago 7.

**AGENTS: Stamping Names on key protectors.** Sample 25c. Starliner outfits, checks, social security and name plates. Hart Mtg. Co., 303 Degraw St., Brooklyn, N. Y.

**AGENTS — 200% Profit selling genuine gold window letters, stores and offices.** Free samples. Metallic Sign Letter Co., 421-D North Clark, Chicago.

**EXCELLENT Sideline for printing and advertising salesmen.** Decalcomania name plates in small quantities. Great demand. Also, make money with our line of automobile initials and sign letters. Free samples. "Ralco" XL-Roxbury, Boston 19, Mass.

**\$1.00 PROFIT Selling \$2.75 photo enlargement deal.** Allen Studio, Riegler Bldg., Little Rock, Ark.

#### SALESMEN—DISTRIBUTORS

**SELL Educational service.** Schools. Thousand month—opportunity. Professor Martin, Orient, So. Dak.

**AMAZING Discovery.** Master Glaze, puts brilliant glass-like surface on cars. Free sample, information. Big commissions. Master Glaze, Dept. 704, 7120 Harwood, Milwaukee, Wis.

**\$10,000 PROFIT Selling printing, matches, specialties!** Arrow dealer tells how he did it in giant free sales outfit. You can do it too—Without experience. Write Arrow Press, 513-C Fourth Ave. So., Minneapolis, Minn.

**SALESMEN—\$50.00 In a day definitely assured.** selling brand new item going to every type of food and beverage store, factories, laboratories, hospitals, etc. Samples furnished. Utility Durawear, 53 West Jackson Blvd., Dept. PM-2, Chicago, Illinois.

**ANYONE Can sell famous Hoover uniforms for beauty shops, waitresses, nurses, doctors, others.** All popular miracle fabrics—Nylon, dacron, orlon. Exclusive styles, top quality. Big cash income now, real future. Equipment free. Hoover, Dept. B-100, New York 11, N. Y.

**SELL Miracle oton embroidered work uniforms.** Looks, feels like wool; wears 3 times longer and washes like cotton. Huge 3-foot wide "Pancratia" line makes sales easy. Amazing profits. Outfit free. Topps, Dept. 512, Rochester, Indiana.

**BIG Money-making opportunity.** Exclusive line work uniforms. Jackets, pants, shirts, coveralls. Advertising embroidered. Every business prospect. Outfit free. Master Dir., 151 Water, Ligonier, Ind.

**SELL Perfume wholesale.** Billows, 110-05 37 Ave., Corona 88, N. Y.

**BUY Wholesale thousands nationally advertised products at big discount.** Free "wholesale plan." American Buyers, 630-DD Linden, Buffalo, N. Y.

**IS \$210 A week worth a postcard to you?** Then rush card with name and address for special free trial plan that sells amazing new automatic refrigerator defroster like hot cakes! Write to Mr. Lewis, D-Frost-O-Matic Corp., Dept. L-102, 173 W. Madison, Chicago 3, Illinois.

**RICH Opportunity for men in their 30's.** Healthful, pleasant occupation. No investment needed. 150 of our men made \$500 to \$3,000 in one month; many just beginners. Heckman made \$104 first 2 hours; Crowley made \$224 first day; exceptional earnings. Openings available. (If you live in Canada write President, Dept. PM-3, 25 Industrial St., Leaside, Ontario.) In U. S.—President, Dept. PM-3, Box 711, Fort Worth 1, Texas.

**GET New shirt outfit free; make \$90.00 weekly on 3 average orders a day.** Famous quality made-to-measure dress and sport shirts at \$3.95 up sell fast to all men. No experience needed. Full or part time. Write Packard Shirt Co., Dept. 601, Terre Haute, Ind.

**BIG Money.** Lifetime repeats. Guaranteed. Wunder Glaze, Bay Port 7, Mich.

**AD Matches! Sell amazing designs—20, 30, 40 and 240-light book matches.** Bigger spot cash commissions; every business a prospect. Low prices for high quality. Repeats. Start without experience; men, women; full, part time. Buy nothing! Sales kit furnished. Match Corp., Dept. PM-50, Chicago 22, Illinois.

**MEN! Moment Miracle Spray-A-Tint tints windshields, gives marvelous glare-protection—Plus new 1934 look! Sprays on in 10 sec. Reduces glare from sun, snow, headlights, etc. Lasts for years.** Auto, truck owners buy on sight! Profits 100% up! Spray-A-Tint, Dept. PM-2, Consumers Bldg., Chicago 4, Illinois.

**ADVERTISING Book matches—Cash in on big demand; sell union label matches.** Cuts for all businesses and political parties. Free powerhouse selling kit, low prices, protection guaranteed on repeat orders. Cash commissions. Superior Match Co., Dept. M-254, 7530 Greenwood, Chicago.

**HAWAIIAN Items, candy, jelly, Lushala, novelties, etc.** Write Maier Products, 1120 Koko Rd Ave., Honolulu.

**MY Free outfit puts you in a line business!** Just two sales a day brings you up to \$217.00 extra a month in big money shoe business. Complete line of Air-Cushion shoes for men, women. Just rush postcard for your powerful free selling outfit. Mason Shoe Mfg. Co., Dept. MC-1, Chippewa Falls, Wisconsin.

**DISTRIBUTORS — Large profits.** Terrific repeat orders. Unique Italian brooms. Write Peacock, 400 Montgomery Street, San Francisco, California.

**MAKE Money with fast-selling Bostonian shirts.** Spare time, full time. Sales kit, actual sample fabrics, free. Bostonian, 89 Bickford, Dept. D-10, Boston 30, Mass.

**NEW Jobs open in selling.** Send name, address for five free issues of Opportunity Magazine's money-making guide, listing hundreds of companies who'll pay you well, full or part-time. No experience needed. Opportunity, 28 E. Jackson, Dept. 17, Chicago 14, Ill.

**MEN** Wanted to sell our established line of nationally known men's hygienic products to physicians and druggists. Extremely long profits. Many ready customers waiting for our salesmen. Free price list upon request. Send \$2.00 for salesman's sample kit including actual samples and prices of merchandise to be sold. Federal Premium Supply, 4507-J Lawrence Ave., Chicago 30, Illinois.

## EDUCATIONAL AND INSTRUCTION

**WELDING** Training pays at Hobart Welding School, Box M-241, Troy, Ohio. VA contract. Best equipment. Catalog free.

**BE** A real estate broker. Study at home. Write for free book today. G.I. approved. Weaver School of Real Estate, 304 Law Bldg., Kansas City, Missouri.

**IT'S** Fun learning another language by Linguaphone. At home, quickly, easily learn to speak French, Spanish, German, Russian, Japanese, Norwegian—29 languages by Linguaphone World's Standard Conversational Method. It's like living in another country. Save time, money. Send for free book. Linguaphone Institute, 8303 14CA Building, New York 20.

**PRACTICAL** Nursing—Learn easily at home, spare time. Big demand, good earnings. High school not necessary. Write for free facts. Wayne School, Dept. FO-21, 2525 Sheffield, Chicago 14, Ill.

**WANT** A diesel job? New opportunities to increase income. Higher pay. More money. We can help you qualify. Tools. Shop method home training. Write today! Diesel, Tractor, Heavy Equipment Division, Interstate Training Service, Dept. B3-B, Portland 13, Oregon.

**HIGH** School diploma at home. Licensed teachers. Approved materials. Southern States Academy, Box 144-MX, Station E, Atlanta, Georgia.

**LEARN** To make miniature photo copies of any picture. Details free. Photo Copy Correspondence School, Room 706, Insurance Center Bldg., Chicago, Ill.

**USED** Correspondence courses and educational books bought, sold, rented. Catalog free. Educational Exchange, Summerville, Ga.

**COMPLETE** Your high school at home in spare time with 57-year-old school. Texts furnished. No classes. Diploma. Information booklet free. American School, Dept. X245, Drexel at 58th, Chicago 37, Illinois.

**IDEAL** Mail order home study course. Particulars free. A. Spencer, Mokena, Ill.

**HIGH** School—No classes. Study at home. Spare time. Diploma awarded. Write for free catalog HF-40, Wayne School, 2527 N. Sheffield, Chicago 14, Ill.

**INVESTIGATE** Accidents—Earn \$750 to \$1000 month. Thousands of insurance companies, airlines, and steamship lines urgently need claim investigators. We train you at home spare time. Placement counsel and help. Free book, now! Universal Schools, Dept. 102, Box 8202, Dallas 3, Texas.

**UPHOLSTERY**—Profitable business, job opportunities; excellent sparetime earnings quickly while training at home with practical N. Y. state approved UTS course. You learn professional furniture upholstery: slip cover, cushion, window cornice, drapery making. You make beautiful upholstered furniture, slip covers while learning. Course includes free, all tools, frames, materials. Free illustrated book. Write today. Also training in N. Y. school. Upholstery Trades School, Dept. CD-1402, 721 Broadway, New York 3.

**QUICK**, Easy, inexpensive preparation for all government jobs. Free catalog. Federal Institute, 304F Chestnut Street, West Hempstead, N. Y.

**LEARN** Priceless secrets of Technical Metaphysics. Easy to learn. Only school of its kind. Write: Premier College of Technical Metaphysics, 2523 McKenzie St., Vancouver, B.C. Canada.

**FINGERPRINTING** Course, \$12.00, details. Alabama School of Fingerprinting, 414 South 10th Street, Bessemer, Alabama.

**TECHNICAL** Textile facts quickly learned easily. Vest pocket booklet. Limited edition. Dollar postpaid. Miller, 315 Bloor Building, Toronto, Canada.

**BLUEPRINT** Reading—Train at home. Learn to read blueprints with confidence in 10 easy lessons. Write today Belton School, Dept. F, 1059 N. Lawndale Ave., Chicago 31, Ill.

**SEWING** Machine repair taught \$5.00. Big money everywhere, easy, pleasant, interesting. Write, Purdy's Guaranteed Instructions, 1416½ North Rusk, Weatherford, Texas.

**STUDY** By correspondence for doctor's degree in psychology, metaphysics and divinity. College of Divine Metaphysics, Dept. P-M, 2611 North Illinois St., Indianapolis 8, Indiana.

**GET** U. S. gov't. job! 350,000 openings expected! Start high as \$315.00 month. Men-women, 18-35. Quality now! Experience often unnecessary. Get free 26-page book showing jobs, salaries, sample tests, opportunities. Write: Franklin Institute, Dept. K-24, Rochester, N. Y.

**YOU** For president of collection agency. We have helped hundreds get their names on office doors. Franklin Credit, Rossmore 7, Virginia.

**TELEGRAPH** Codes easily learned with Simplex teaching machine. Free particulars. Harris, 9534-P Lemturner, Jacksonville 6, Florida.

A College B.A. and M.A. degree by home study. State chartered. Fremont College, 915 Grand View St., Los Angeles 6, Calif.

**DOES** Your child read well? Get quick results worth \$200 to over \$1,000 in your own home. Guaranteed course costs only \$20. Herbert Sage School, 631 North 50th St., Seattle, Washington.

**ENGINEERING**. Home study, catalog free. Midwest Engineering School, 10923 Hillcrest, Hickman Mills, Missouri.

**SMASH** Worries, fears and problems with our life-changing "Thought and Behavior Control" method. Many helped. Write today for free eye-opening lecture and full details. Personal Psychology, Inc., Box 1924-E, Louisville 1, Ky.

**MATHEMATICS**, Physics, drafting, etc. Individualized, personalized instruction. Low cost. Literature free. Technical instruction by correspondence. C. S., P.O. Box 69, Cambridge, Mass.

**INCREDIBLE!** Become mental superman overnight! Free booklet! Bijou, Box 1227-ME, Hollywood 28, California.

**3800** USED Correspondence courses, catalog \$1.00. Cartoonist course, \$3.95. EO, Elmford, New York.

**GROW** Mushrooms. Cellar, shed, and outdoors. Spare, full time, year round. We pay \$3.50 lb. We paid Rabbit \$4,165.00 in few weeks. Free book. Washington Mushroom Ind., Dept. 174, 2954 Admiral Way, Seattle, Washington.

**PIANO** Tuning pays. Learn this profitable profession at home. Our Tunometer and mechanical aids make learning easy. No knowledge music necessary. Diploma granted. Largest and oldest school—39th year, G.I. approved. Write for booklet, Niles Bryant School, 78 Bryant Bldg., Washington 16, D. C.

**SECRET** Investigation. Experience unnecessary. Investigators particulars free. George Wagner, 3125 West 88th, New York 24.

**OIL** Coloring photographs—A fascinating hobby or profitable sideline for those with artistic talent. Learn at home. Easy simplified method. Free booklet. National Photo Coloring School, 335 Diversey Parkway, Dept. 3432, Chicago 14.

**LEARN** Drafting—Write for free booklet, "Drafting Opportunities in Industry." Gesco Industrial Training Services, 1704-A Frederick, Fort Worth 7, Texas.

**UPHOLSTERING**—Train at home for prosperous business. Tools, supplies sent. Illustrated training shows you—previous experience unnecessary. Establish full or part time business. Free booklet explains plan. Write Commercial Trades Institute, 1400 Greenleaf, Dept. U2A-1, Chicago 26.

**BE** Independent. Learn auctioneering. Literature free. Fennell, 804 West Magnolia, San Antonio 1, Texas.

**CORRESPONDENCE** Courses, educational books, bought, sold, rented. Lists free. Magnolia Press, Box 1972-P, Burbank, Calif.

**PENMANSHIP** Courses. Improve your writing quickly. Learn shaded writing. Greeting cards—Name cards, elegantly written. Free literature. Teris, A-25, Chillietho, Mo.

**MIDLAND** Linotype School. Charles City, Iowa. Clevland and Veteran Courses. Free placement. Established 1909.

**EARN** While you learn. Auto and diesel mechanics master this top paying trade. Many graduates earn \$100 a week and up. Approved for Korean veterans. For free information write Dept. No. 256, Nashville Auto-Diesel College, Nashville 3, Tenn.

**BOOKKEEPERS!** Increase your earnings! Operate your own simplified "Dollar-A-Week" bookkeeping and tax service. Full or spare time. Details free. No obligation. Ellis, Box 200, Cedar Grove, North Carolina.

**MEDICAL** Laboratory technicians in great demand. We train you in your own home. Catalogue free. Imperial Technical Institute, Box 923-J, Austin, Texas.

**INVESTIGATOR** Training. Phillip Secret Service System, 1017-B North Kennebec, Chicago 38.

**USED** Correspondence courses and books sold and rented. Money back guarantee. Catalog free. (Courses bought.) Lee Mountain, Pisgah, Alabama.

**GOVERNMENT** Position! Home training for examination, \$9.95. Refunded if don't pass. Write, Osment Instructions, 34-08, St. Louis, Mo.

**SIMPLIFIED** Analytics teach algebra instantly; \$1.00, guaranteed. Ziembeck, 6123 Orchard, Dearborn, Mich.

## PLAYS, STORIES, MANUSCRIPTS

**HOW** To write short stories, mysteries, articles. Learn at home for career or extra part-time income. Graham Dour sold one story to Post, CBS radio and NBC-TV. Professional writers show you how. Send today for free lesson. Palmer Institute of Authorship, Desk TM-24, 1880 N. Bynamore, Hollywood 28, Calif.

**BEGINNING** Writers: Get \$1 to \$20 checks daily writing simple children's stories, articles, poetry in your sparetime. Experience unnecessary. Our instructions reveal how. Details free. W. Herman, 5927 Euclid, Cleveland 3, Ohio.

**WRITE** For pay—Cash checks of \$1 to \$100 offered daily. Learn professional writers' secrets at home. Free details. Cummings Institute, Box 17006, Studio B-11, Los Angeles, Calif.

**NO** Luck finding a book publisher? Write for free Booklet PM. Vantage Press, 129 W. 21, New York.

## BUSINESS SERVICE

**TUCSON** Postmark! Confidential! Letters 25c plus postage. Hugh Melroy, 2914 N. Goyette Ave., Tucson, Arizona.

## SPECIAL SERVICES

**SOURCE** Of American made items found, only \$1.00. Satisfaction or money back. Massachusetts Research Service, 15-A Garfield Street, Taunton, Mass.

**PHOTOSTATS** Up to 8½x11 25c each, cash with order. Returned postpaid. Golub, 8825 23rd Ave., Brooklyn 14, N. Y.

**VALLEY** Of the sun. Prompt replies. 20c; postcards 7, \$1.00. Ratner, 3008 W. El Caminito, Phoenix, Arizona.

**NEW** York help-wanted columns, any local information airmailed, \$1. Engel, 2016 Tinslinson, New York 51.

**SOUTHERN** California: Latest information on business and job opportunities, housing. Send \$2.00 to Lawrence Taylor, 1749 Sateau, Northridge, California.

**PROMPT**, Reliable information on any subject. Questions on matters of fact answered, \$2.00 each. Gordon Research, Box 1427, Chicago 90.

**INFORMATION** On any matter. Ferguson Research, 118-14 141 St., South Ozone Park 26, N. Y.

**VENEZUELA** Remail, letters airmailed \$1.00. J. Small, Aeroven, Apt. 2165, Ciudad Bolivar, Venezuela.

**REMAILS** From Tijuana, Mexico, 25c each. Nuñez, Box 1131, San Ysidro, Calif.

**ARE** Sales your problem? Let our experienced sales organization analyze your product. We will provide detailed report of best possible distribution plan. Have national distribution contacts. Only products we believe have merit accepted for survey. No charge made unless extensive survey requested. Send sample, or photo, and particulars to: Sales Research, Inc., 629 West Martin, San Antonio, Texas.

**WRITERS!** Send 50c. List 100 markets. International Bureau, Box 137-CPD, New York City.

LETTERS Remailed from Times Square 25c. Bert-Ley, 155 W. 72 St., New York 23.

**MAKE** Your will now! Will form, instructions and seals \$1 postpaid, 3 for \$2. Pacific Research, Box 007, Phoenix, Ariz.

LETTERS Remailed. Write for rates. Remail Service, 4560 North 14th Street, Omaha, Nebraska.

### CARTOONING, COMMERCIAL ART, SHOWCARD WRITING, SIGN PAINTING

"HOW To Make Money With Simple Cartoons"—A book everyone who likes to draw should have. It is free; no obligation. Simply address Cartoonists' Exchange, Dept. 92C, Pleasant Hill, Ohio.

**PAINT** Signs and show cards. Biggest complete course with 324 illustrations (16 in color) \$5 postpaid. Descriptive circular free. E. C. Matthews, 2323 Cass, St. Louis 8, Missouri.

**BARGAINS**, Quick landscape painting, poster art, lettering, cartooning. Catalog 10c. Art Book Shop, Arnold 3, Missouri.

**CHALK** Talks. Laugh producing program, \$1.00. Catalog 10c. Balda The Cartoonist, Oshkosh, Wisconsin.

### ADVERTISING AGENCIES, LETTER WRITERS, FOR ADVERTISERS

"HOW To Get Your Name in Paper." Tells publicity secrets. \$1.00. Hall, 47 E. 81 St., New York.

**FREE!** 1954 Advertisers Rate and Data Directory. 52 pages! E. H. Brown Advertising Agency, 20 N. Wacker, Chicago 8.

**FREE!** 1954 Advertiser's Guide, Rates, ideas, publicity service. BT Nationwide Advertising Service, 2108 Payne, Cleveland, Ohio.

**FREE** Copy, layout service. Mailorder ad, 1,700,000 nationwide circulation, \$27.30 inch. 24-word classified. 20 big Sunday newspapers, \$30.00. Advertising ratebook free. Chicago Advertising Agency (established 1900), Chicago 4.

**MAILING** Lists, most any classification. 1000 names \$5.00. 1000 your circulars mailed with ours \$4.00. 5000 your circulars printed and mailed \$12.95. Write Dixie Mailers, King, North Carolina.

**ADVERTISE:** 24 Words, 100 Canadian newspapers \$5.50. Lists free. Advertising Bureau, 10511-C Springfield, Chicago 43.

**ADB** Placed in out of town newspapers and magazines. Low rates. Catalogue free. Ideas that pay. Baker Advertising Agency, Successors Andrum Agency, 189 W. Madison, Chicago 2.

**ADVERTISERS!** Reach nearly 10,000,000 readers. 25 Sunday national key newspapers. 18 words, \$59.00. "Terrific pullers." 20 popular newspapers, \$11.50. Free booklet. Special—One inch display 2-321,198 circulation. \$41.10. Newark's Advertising Agency, (Established 1893), 317-7th Ave., New York 11.

### RUBBER STAMPS AND OFFICE SUPPLIES

**3-LINE** Stamp, knob handle, cushion mount, indexed, \$1.00. Inked pads, any color, 40c. Orders shipped same day received. Smithfield, Box 10201, Houston 12, Texas.

**RUBBER** Stamps by professional craftsmen, 3 lines \$1.00. Price list. South Coast Press, 2128 Mt. View, San Bernardino, California.

**HANDY** Pocket rubber stamp. 3 lines, self-inking pad, plastic case \$1.00. William C. Anderson, Mountain Home, Tenn.

**NO** Lower prices anywhere. 3 lines 45c; 3, 6c; 4, 8c; 5, \$1.00; 6, \$1.20. Stamps of cuts any size, style. Get quantity prices. Free catalog. Ecco 24 Print, 6 Holt, Dayton 7, Ohio.

**3 LINES**, \$1.00. Fast service! Catalogue, Johnson Press, Box 8-A, New York City 26.

### TYPEWRITERS, DUPLICATORS, OFFICE DEVICES

**TYPEWRITERS**, Adding machines, duplicators, supplies. Miller, Box 563-P, Poteau, Okla.

**ADDING**-Subtracting Machine \$14.95. New, Guaranteed. Free literature. Jackson, Box 27M, Alhambra, California.

**VARTYPER**, Electric typewriters, \$110. Sachs, 119 W. 23 (PM), New York 11, N.Y.

**RECONDITIONED** Typewriters, duplicating, printing devices, \$25.00 up. Supplies. Appliances. DixieGraph, King, N. C.

### PRINTING, MULTIGRAPHING, MIMEOGRAPHING, GUMMED LABELS

**BUSINESS** Cards, Printing, Reasonable. Free samples. Lites, 5352-PM Princeton, Chicago 9.

**1000** 3/8x2 1/2 **GUMMED** Labels neatly printed with your name, business, address, \$1 postpaid. Other sizes, Samples free. Cramer, 1010 East Morgan, Martinsville, Indiana.

**QUALITY** Cards boost prestige and profit. Free samples. Bowden, 7160 Attention SE, Washington 22, D. C.

**ATTRACTIVE** Printing, stickers, labels. Inexpensive. Samples, Fame, 291 Ellis, San Francisco 2, Calif.

**MAKE** Your own cuts. New simple process. Low cost. Literature free. Walp, P.O. Box 4300-M, Mobile, Ala.

**1000** **CALNDAR** Back business cards \$3.55 prepaid. Frank Elstinger, 781-17 Southern Blvd., Bronx, New York 55, N. Y.

**MIMEOGRAPHING**—Anything! 200, 8 1/2 x 11, \$3.00. Guaranteed. Free samples. Quinn Sales, P.O. Box 967, Little Rock, Ark.

**BETTER** Printing—Reasonable prices. Free estimates. Samples. Reporter, Chelsea, Oklahoma.

**ENVELOPES** 6 1/2, \$4.00—1M (o.b. Aneralia, 1423-A Edwards, New York 61, N. Y.

**1000** **BOND** Letterheads, 5 1/2" x 8 1/2", \$5.75, postpaid. Taylor, Box 265, Petersburg, West Virginia.

**1000** **EMBOSSED** Business cards. 1954 calendar on back. \$3.95 delivered. The Guild, 2702 Georgia Avenue, Washington, D. C.

**OFFSET** Printing—Letterheads, envelopes, forms, \$3.50 per 1000, London, Box 1756, New London 2, Conn.

**TWO** Color 8 1/2x11 letterheads. 500, \$3.50. Samples. D'Yarmett Printing, Newark, Ohio.

**100** **ENVELOPES**, Printed 2-colors \$1.25. Box 528, Rochester 2, N. Y.

**DISTINCTIVE** Raised print business cards, 29 type styles, free samples, type chart, and price list. Write A. O. Geraig, Box 335, Columbus 4, Ohio.

**100** **NOTEHEADS** And 100 envelopes, \$1 postpaid. DiBenedetto's Printers, Box 171, Chelsea, Mass.

**JOB** Printing, Letterheads, envelopes, circulars. Printing, 21, Barclay, Portsmouth, Virginia.

**100** **PRINTED** Envelopes or letterheads \$1.00. Two colors \$1.50. Broadbrook, Balford, Conn.

**125** 3 1/2x11 **LETTERHEADS** And 125 6 1/2 envelopes \$7.50 postpaid. 250 of each \$4.50. Going Print Shop, Box 1544A, Muskogee, Oklahoma.

**100** 3 1/2x11 **LETTERHEADS**, Carefully printed, \$1.00 postpaid. Envelopes same. Race Printers, Hudson, New York.

**100** 3 1/2x11 **LETTERHEADS**, 100 6 1/2 Envelopes \$2.00. 250 each, \$3.75. 500 business cards \$1.95; 1000, \$2.50. Standard copy. Postpaid. Allen, Dept. PMP, Clinton, Missouri.

**MIMEOGRAPHING**—Letters, price lists, formulas, instructions. Lowest prices. Lem's Letter Shop, 5710 Stanton, Detroit 8.

**500** 3/8x2 1/2 **FOUR** Line gummed stickers 50c. Red border \$1.00. Moritz Printers, Saginaw, Mich.

**BUSINESS**, Personal stationery. Catalogs free. Rowprint, T23-M Eunice, Webster Groves 18, Missouri.

### PRINTING OUTFITS AND SUPPLIES

**MAKE** Your own self-molding rubber printing cuts. Plastirubber, Anxyle 1, Wis.

**PRESSES**, Supplies, paper, Catalog 10c. Custom, Box 311-P, Springfield, Missouri.

**PRESSES**, Type, cabinets, supplies, List for stamp. Lincoln Press Company, 220-B Hartwell, Fall River, Mass.

**DO** Your own printing. Save money. Simple rules. We supply everything. Print for others; good profit. Raised printing like engraving too. Have home shop. Details free. Kelsey Presses, V-11, Meriden, Connecticut.

**PRINTING** Presses, type, supplies. Lites 3c. Turnbaugh Service, Lewisville, Penna.

### PATENT ATTORNEYS

**INVENTORS**—If you consider your invention to be something of importance, take steps to protect it with a United States Patent which gives you the right to exclude others from making, using and selling your invention as claimed. "Patent Protection for Inventors" outlines steps to take to secure patent protection. Mailed promptly without obligation. Victor J. Evans & Co., Merlin M. Evans, Registered Patent Attorney, 931-B Merlin Building, Washington 6, D. C.

**INVENTORS**—If you believe you have an invention, you should find out how to protect it. The firm of McMorrow, Berman & Davidson with offices in Washington, D. C., is qualified to take the necessary steps for you. Send for copy of our patent booklet "How to Protect Your Invention." We will also send you an "Invention Record" form. No obligation. They are yours for the asking. McMorrow, Berman & Davidson, Registered Patent Attorneys, 1345 Victor Building, Washington 1, D. C.

**CANADA**—Ramsey Company Registered, 273 Bank Street, Ottawa, Canada.

"**INVENTOR'S** Guide" and "Record of Invention" free on request. Frank P. Ledermann, Registered Patent Attorney, 154 Nassau Street, New York City.

**ALL** Latin America, patents, trademarks, pharmaceutical licenses. Box 890, Lupa, Bolivia.

**PATENTS**—Irving L. McCallahan, 315 McLaughlin Bldg., Washington 1, D. C. Registered Patent Attorney.

**REGISTERED** Patent attorney offers services. Sanders, 6430 Evans, Chicago 37, Ill.

**INVENTORS:** When you are satisfied that you have invented something of value write me, without obligation, for information as to what steps you should take to secure a patent. Write Patrick D. Beavers, Registered Patent Atty., 925 Columbian Bldg., Washington 1, D. C.

**PATENTS**, "Proof of Invention" free. E. E. Vrooman, Registered Patent Attorney, 507 McKim Building, Washington 5, D. C.

**INVENTORS:** Without obligation, write for information explaining the steps you should take to secure a patent. John N. Randolph, Registered Patent Attorney, 203 Columbian Bldg., Washington 1, D. C.

**C. A. Snow & Co.**—M427, Snow Building, Washington 1, D. C. Registered Patent Attorneys. Write for information.

**INVENTORS**—For "Invention Record" form, contact Carl Miller, Registered Patent Attorney, Woolworth Building, New York.

**INVENTORS:** Learn how to protect your invention. Unless the inventor is familiar with patent matters, he should engage a competent registered patent attorney or agent to represent him. We are registered to practice before the U.S. Patent Office and prepared to serve you in handling your patent matters. "Patent Guide for the Inventor" containing detailed information concerning patent protection and procedure with "Record of Invention" form will be forwarded to you upon request—without obligation. Clarence A. O'Brien & Harvey Jacobson, Registered Patent Attorneys, 41B-A District National Building, Washington, D. C.

### FOR INVENTORS

**INVENTORS**—If you believe you have an invention, you should find out how to protect it. The firm of McMorrow, Berman & Davidson with offices in Washington, D.C., is qualified to take the necessary steps for you. Send for copy of our patent booklet "How to Protect Your Invention." We will also send you an "Invention Record" form. No obligation. They are yours for the asking. McMorrow, Berman & Davidson, Registered Patent Attorneys, 1344 Victor Building, Washington 1, D. C.

**INVENTORS**—This firm is registered to practice before the United States Patent Office and is available to assist you in the preparation and prosecution of your patent application. "Patent Protection for Inventors" booklet containing detailed information and steps to take toward patent protection will be sent upon request. No obligation. Victor J. Evans & Co., 933-B Merlin Building, Washington 6, D. C.

**INVENTORS**—Why lose money? Protect and promote your invention in Europe. Details from Madison Associates, 182 Kaiserswertherstr., Durseldorf, Germany.



**INVENTORS**—Send for free patent information book and inventor's record. Registered Patent Attorney, Associate Examiner, Patent Office 1922-29; Patent Attorney & Advisor, Navy Department 1930-47. Gustave Miller, 24A Warner Building, Washington 4, D. C.

MY 7th Invention paid \$730,000.00. Others paid well. I learned the hard way what inventors should know, must avoid. My new book tells all. can save you thousands. help you make fortune. Only \$1. Refunded if not delighted. Write Inventor's Press, Postoffice Box 5, Station B, Omaha, Nebraska.

**INVENTORS**. Deal direct with manufacturers. Write David A. Lee, Box 53, Norfolk 1, Virginia.

**PATENTS** Rewritten simply, clearly, sell easier. Free information. Lehr, 17595 Strathmoor, Detroit 35, Michigan.

**PERPETUAL** Motion impossible without overcoming friction. Bulletin 12, \$1.00, describes simple, cleverly contrived, magnetic arrangement for overcoming friction. Numerous ideas included. Cash for your ideas printed. Bulletin if available. Ideas, 310-A Harlem, Glenview, Ill.

**INTERNATIONAL** Inventors Club memberships open for limited time. Members benefits include: Low patent fees, patent and marketing help, trademark and copyright help, foreign patent information, many others. Membership \$15 year. Request free information, 6014 Metropolitan Station, Los Angeles 55, California.

**PATENT** Searches \$5.00. Complete reports airmailed within 48 hours. Free invention protection forms. Write Miss Ann Hastings, P.O. Box 178, Washington 4, D. C.

**INVENTORS**—Learn how to protect your invention. Unless the inventor is familiar with patent matters, he should engage a competent registered patent attorney or agent to represent him. We are registered to practice before the U.S. Patent Office and prepared to serve you in handling your patent matters. "Patent Guide for the Inventor" containing detailed information concerning patent protection and procedure with "Record of Invention" form will be forwarded to you upon request—without obligation. Clarence A. O'Brien & Harvey Jacobson, Registered Patent Attorneys, 414-A District National Building, Washington, D. C.

**PATENT** Searches \$5.00. 48-hour service. Free record of invention. Write Raymond L. Smith, Patent Searches, 623 Sheraton Building, Washington 5, D. C.

**PATENT** Searches \$5.00. 48-hour airmail service. Record of invention forms free. Patent drawings prepared. Write Patent Engineering Service, 711 14th Street, N.W., Washington 5, D. C.

**INVENTORS**. "Thirty Years Experience with Inventions and Inventors" is an education in dealing with lawyers, patent attorneys, patent brokers and financiers worth thousands of dollars. Don't mortgage your home until you have read this copyrighted book. Price \$5.00. Full information free. Claudius Nielsen, Consulting Engineer, P.O. Box 4793-A, Detroit 18, Mich.

**PATENT** Searches. \$5.00, including patent copies. Same reliable search as conducted for patent attorneys. Free protection forms. Patent Service Institute, 948-A Pennsylvania Avenue, Washington 4, D. C.

**CASH** For your idea. 280 manufacturers need inventions, patented or unpatented. List free. Invention Bureau, 268M Clinton, Oak Park, Ill.

**INVENTORS** — For "Invention Record" form, contact Carl Miller, Registered Patent Attorney, Woolworth Building, New York.

**MAKE** Money from your ideas, gadgets, patents. Get "Inventors Guide," helpful book tells you how. Send \$1.00, includes list of needed inventions. We have buyers. Inventors Creative Service, 354 South Spring, Los Angeles 13, Calif.

**SEARCHES**—Put your patent searches in the hands of a registered patent attorney or agent, as he qualifies to give a worthwhile patentability report. Record of invention form upon request and information on patent protection. Patrick D. Beavers, Registered Patent Attorney, 930 Columbian Bldg., Washington 1, D. C.

**INVENTORS**—Information on patent procedure furnished on request, without obligation. John Randolph, Registered Patent Attorney, 362 Columbian Building, Washington 1, D. C.

I Sell patents. Established 1900. Charles A. Scott, 772PM Carson Avenue, Rochester 9, N. Y.

**INVENTORS**: If you have an invention for sale, patented or unpatented, write Institute of American Inventors, Dept. 40A, 631-E St. N.W., Washington 4, D. C.

"INVENTOR'S Guide" and "Record of Invention" free on request. Frank P. Ledermann, 154 Nassau Street, New York 38, N. Y.

### INVENTIONS WANTED

**INVENTORS**: If your invention is adaptable to our business we will contract on cash or royalty basis. If not, we will try to place. Write today. Kessler Sales Company, Dept. 52, Fremont, Ohio.

**PROGRESSIVE**, reputable company wants inventions now in production or ideas fully worked out. Prefer wrenches, tools or attachments for electric drills. Will purchase or lease on royalty basis. Send pictures with full data. The Drilo Corporation, 200 East Carson Street, Pittsburg 18, Penna.

**INVENTIONS** Wanted: Patented; patentable. Extensive manufacturers lists. Personal contact with executives coast to coast. Particulars from Superior, 240 South Beverly, Beverly Hills, Calif.

**WE** Buy inventions for cash or lease on royalty. We are principals not brokers or agents. We finance the manufacturing and national distribution. You invest nothing. Bronstone's Inc., 756 South Broadway, Los Angeles.

**WILL** Buy or manufacture on royalty basis, your patent pertaining to dense rubber products, molded, extruded, calendared, dye cut, and bonded to metal. Address Lyle F. Runciman, Vice Pres., Rubber Manufacturing Co., 3580 West Fort St., Detroit 16, Mich.

**CASH** Buyers for ideas and inventions. Write National Inventors Institute, 4007 East 131st St., Cleveland 5, Ohio.

**INVENTIONS** Promoted, Patented or unpatented. Established 1911. Write Adam Fisher Company, 61 Enright, St. Louis, Mo.

**INVENTIONS** Wanted. Patented; unpatented. Tremendous manufacturers lists. Global Marketing Service, 1404 Mitchell, Oakland 1, California.

**INVENTIONS** Wanted. Patented or patent pending. 21 years experience promoting inventions. National Service Bureau, 3120 Meramec, St. Louis 13, Mo.

### PATENTS FOR SALE

**CHILDREN'S** Desk-chair combination, tubing, plastics. Patent 2,459,257. Halbert Wood, 2300 South Park, Madison, Wis.

**INVENTORS**—Test the commercial value of your patented or unpatented inventions, quickly and inexpensively. Write for free information. Institute of American Inventors, Dept. 40-B, 631-E St. N.W., Washington 4, D. C.

### MANUFACTURING

**MODELS**—Small lot manufacturing. Metals, plastics, etc. Milburn, Burlington, Kentucky.

### MODELS, MODEL SUPPLIES

**LIVE** Steam engine, 10 1/2" high, ready-to-run, \$5.95 postpaid. Catalog 35c. Merlo, 50-18 94th Street, Elmhurst 13, N. Y.

**BRASS** Gears and model supplies for the inventor. Send 10c for catalog. Pierce Model Works, Tinker Park, Ill.

**1954** CAR Models. 1/25 scale, all metal, chrome trim. Send for catalog. Cars and Hobbies, Dept. PM-15, 2333 Haddon, Chicago.

**SHIP** And yacht model fittings; blueprints. Send 25c for illustrated catalog listing hundreds of items. A. J. Fisher, 1002-1 Blouah Ave., Royal Oak, Mich.

**FIBERGLAS** Cover or build your model boats, planes, cars, etc. with miracle Fiberglas. Complete hobby kit and instructions \$5.00. United States Fiberglas-Resin Company, 722 East Washington, Los Angeles 21, California.

**NEW** Completely revised giant 88-page 1954 "O" gauge catalog for model railroads. Scale and timetable. Fully illustrated. Hundreds of car kits all types, steam locomotives, diesels, specialty items and parts galore. Catalog cost of 75c refunded with first \$5.00 order. All-Nation Hobby Shop, 183 N. La Salle St., Dept. A, Chicago 1, Ill.

**BUILD** Historic ships, vehicles. 50c to \$9.00 kits. Illustrated catalog 10c. Ideal Models, 21 West 16th Street, New York 11.

**POWER** Models. Unusual steam, gas-line and traction engines. Fittings, metals. Anniversary catalog 50c. Chas. Cole, Ventura, Calif.

**STEAM** Locomotives, 1 1/2", 1", 3/4", 1/2", 1/4" scales. Castings, rail, steam fittings. Thorough drawings with instructions. Catalog 50c. Little Engines, Wilmington, California.

**SHIP** And other scale models. Most complete line in New England. Kits, fittings, plans, books, tools, engines, motors. Illustrated catalog 25c. James Bliss & Co., Inc., Dept. 2M, 342 Atlantic Ave., Boston 10, Mass.

**BALSA** Wood, Grade AAA. Free sample, price list. Big Mfg. Co., Montezuma, Iowa.

### HOME CRAFTSMEN

**GRANDFATHER** Clocks, weight driven movements. Wills Bros., 257 South Ellwood Ave., Baltimore 24, Maryland.

**16** NEW Lawn chairs, 22 picnic tables, benches, trlles, etc. All 36 plans with necessary full size patterns, \$1.00. Mastercraft 33M, 7041 Cicott, Chicago 31, Ill.

**VIOLINMAKERS**. Amateurs, professionals. Fine tone European wood. Materials, tools, supplies, patterns, instructions. Illustrated catalogue 10c. Refundable. Premier Violin Supplies, 430 South Broadway, Division PVM, Los Angeles 13, Calif.

**PLASTICS** Home-craft course for men and women. Tells and shows how to make hundreds of fast selling plastics products. All plastics and materials for 23 projects included in course. No special tools needed. Course pays for itself. Write for free booklet. Interstate Training Service, Dept. D-3-B, Portland 13, Oregon.

**PETER** Pan, Snow White, Seven Dwarfs, Cinderella, Red Riding Hood, etc. Full size patterns 16" to 24" high. All for \$1.00. Mastercraft 37M, 7041 Cicott, Chicago 31, Ill.

**FREE** Aircraft catalog. Designs imprinted brass, copper, aluminum for metal pictures; burnt wood etchings; glorified glass, mirrors; pre-sketched paintings. Profitable art hobbies. Dept. PM, Thayer & Chandler, 910 W. VanBuren, Chicago 7, Illinois.

**LEATHERCRAFT** For pleasure or profit. Make easy-to-assemble purses, belts, gloves, woolskin toys, 100 other items for gifts or to sell. Send 10c today for big catalog. Largest leathercraft stock in U. S. J. C. Larson Co., 830 E. Tripp, Dept. 2958, Chicago 24.

**LEATHERCRAFT** Supplies. Pre-cut kits, tools, etc., large stock. Catalog 10c, refundable first order. Whitman Saddle Mfg. Co., 1725 Powers St., C3, Cincinnati 23, Ohio.

**BUY** Wholesale nationally advertised power, hand tools, thousands other products at big discounts. Free "wholesale plan." American Buyers, 633-RR Linden, Buffalo 16, N. Y.

**JOSAW** Owners attention! Start earning money at home cutting out wooden novelties and souvenirs. Write R. Cook, Dept. A, 4407 S. Normal Ave., Chicago 8, Illinois.

**101** FULL Size patterns. Smart, new, gifts, novelties, lawn figures, shingles, nation windmills, alphabets. Plus "Make Money Jig Saws." Only \$1.00. Mastercraft 35M, 7041 Cicott, Chicago 31, Illinois.

**LEATHER** Crab bag! Direct from Tannery. Check full of beautiful pieces, all sizes, all colors. Have fun, earn money making coin purses, key cases, dozens of other items for gifts or sale. Amazing value, only \$1. No c.o.d.'s. Moneyback guarantee. Dept. 60, Tannery-Outlet, 145 South St., 3rd floor, Boston, Mass.

**LAMP** Size express knee \$1.00. Cy Products, Dept. 1, Latapeta, La.

**ASSEMBLE** Jewelry, gifts. Free catalog, details. Novelcrafts Co., 25 Adrian Ave., New York 43, N. Y.

**ALUMINUM**. Dress, copper spinning to your specifications. Siegle, Box 5, Jamaica 11, N. Y.

**MAKE** Beautiful knotty pine lamp. One evening project, complete instructions and all hardware, socket, plug, cord, nipple, base, locking and final, plus base kit. \$1.95 postpaid. Lamps, Box 222, Scott, Ia.

**33** LAWN And garden ornament patterns. Full size, ready cut, colors indicated. Only \$1.00. Lincoln Craft Studio, Columbia, Conn.

**JIGSAW Patterns!** Large variety especially for boys, \$1.00. Pads, 223A North 35th, Milwaukee 8, Wis.

**FREE: 138 Pictures;** woodworking designs; originals. Write Spears, Bedford Hills, New York.

**LEATHERCRAFTERS:** Illustrated catalog shows everything you need, 10c. Complete stock "Craftool" stamps. Art Leatherer, 411 Joseph Ave., Rochester 5, N. Y.

**ALUMINUM,** Brass, copper sheet, red. Price list free. Arbott's, Box 294, Aber Road, R.D. #1, Verona, Penna.

**START A leather carving spree!** With catalog that's free! Good for ages 7 to 83. Write to Tandy Leather Company, P.O. Box 387B in Tulsa, Oklahoma.

**PINE Knot** for beautiful driftwood lamp. \$1.00 plus postage c.o.d. Instructions included. Goyer's Sales, Sheridan, Michigan.

**RARE Myrtlewood.** Beautiful natural coloring. Makes excellent lamps, bowls, etc. Most sizes available. \$1.00 board foot. Shields, 583 Bandon, Oregon.

**AMAZING Round hacksaw blades.** Saw in any direction, wood, steel, plastics, etc. Plus standard hacksaws. Rough, medium, smooth 10" blades \$1.95. Uniyersal, 113 West 42nd St., New York, N. Y.

**NEW Aluminum and brass sheet strips and blanks** 10 lbs. \$3.50 plus express. E. Cohn & Sons, Cedar Rapids, Iowa.

**PAINT Miniatures, ceramics, models, photos.** Imported needlepoint brush, \$1.00. Mastercraft, 3117 Pennway Ave., Philadelphia 24, Penna.

**REFINISHERS.** Small shops; we specializing in industrial type wood finishing materials, small or large units, our catalog contains brush or spray specifications for 21 different "Modern Furniture Finishes." Send 25c for catalog. Gaston Finishes, Box 448N, Bloomington, Indiana.

**KNOCKDOWN TV stool.** Colonial style, rush seating. Circular free. Nelson Rapids Co., 1834 Nelson Ave., Grand Rapids 7, Michigan.

**CRAFT Leathers, supplies, incins, kits, tools.** Send 25c for latest catalog. Jonas Handicraft Co., 30 Frankfort Street, New York 38, N. Y.

**KNOCKDOWN Pine picture frames.** 3-5"x7" \$1.00. D. Genovese, 8 Liberty St., Stamford, Conn.

**FREE Craft catalog** of metal, plastics, leather, lamp shades, cork, seed, cane, and many others. Craftsman Supply House, Scottsville 11, N. Y.

**\$500 FROM \$15 Worth pine boards.** Complete plans \$1. Cooke, Stoddard, Wis.

**31 ORIGINAL Idea jig saw patterns** \$1.00. Professional drawing, quality printing. Full size shelves, toys, lawn ornaments, novelties. Walker Studio, V2-PM, 4343 Lindell, St. Louis 8, Mo.

**FREE Do-it-yourself leathercraft catalog.** Tandy Leather Co., Box 781-VV, Fort Worth, Texas.

**YOU Can make cement bird baths, lawn statuary, animals, fowl.** Send \$1 for catalog and instructions. Specialty Forms, Drawer 60-M, Hickory, N. C.

**LEATHERCRAFT.** Tremendous stock of leather, tools, supplies, and kits. In leather business over forty years. Send 10c for big catalog. Sax Bros., 1111 No. 3rd, Dept. PM1, Milwaukee 3, Wisconsin.

**HOBBYISTS.** Steel, aluminum, brass, rod, sheet, catalogue. Arcy Co., Lynbrook, N. Y.

**PILLOFOAM** By Dunlop. First in foam rubber. From 1/2" to 4 1/2" thickness. 1"-59c, 1 1/2"-\$1.30, 2"-\$1.67 sq. ft. Pillows, Mattresses. Send dime for price list and powder puff. Foam Rubber Centre, 1680 W. 8th, Vancouver, B. C., Canada.

**KNOCKDOWN Cedar chests.** Lumber and veneers. Free price list. Giles & Kendall Company, Huntsville, Ala.

**FURNITURE Handles.** Solid brass. Free literature. Colony House, Box 1692, Huntington, West Virginia.

**100 FULL Size jig saw patterns** up to 20" high, only \$1.00. Pattern Service, Medway 9, Mass.

**\$45 FROM Square foot plywood;** jig saw necessary. Write: Woodarts, Bridgewater, Mass.

**129 NEW Full size jig saw patterns.** Unusual novelties, gifts, lawn figures up to 22 inches high, action (mercy-go-round) windmill, toys, useful gadgets. Artist drawn, \$1. Craftplans, 1321-A South Michigan, Chicago 3.

**FREE Information.** Money-making full size patterns. Professional designs. Furniture, gift shop items. Write Jigsawers, 117 Worth, New York 13.

**SPECIAL Offer.** 102 full size jig saw patterns only \$1.00. Lynds, 71 Park, Natick, Mass.

**LEATHERCRAFT—New stylecraft folder free.** New kits illustrated. Filigree belts, billfolds, purses, etc. Send 25c new catalog. Refunded first order. Apache Leather Co., 2804 East Washington St., Phoenix, Arizona.

**LEATHER, Tools, incins, supplies.** Free catalog. National Handicraft, 199 William St., New York 7.

**"TOPS" in everything for leathercraft.** Lowest prices. Genuine "Craftool" stamps. Catalog 10c. Crown Leather Company, 22 Spruce Street, New York 38.

**KNOCKDOWN Cedar chests and lumber.** Free price list. Bedford Lumber Company, Shelbyville, Tennessee.

**LEATHERCRAFT.** Metal tooling, textile painting, beadcraft, shellcraft. Many other crafts. Send for free, big, illustrated catalog today! Kit Kraft, Hollywood 36, Calif.

### MAKE IT YOURSELF

**WATER Softener tanks, zeolite and parts.** Assemble your own softener or filter. J. T. McCarthy Co., 2930 W. Burlington St., Milwaukee 10, Wis.

**MAKE Your own electric fuse plugs.** Model \$1.00. W. Stonebraker, 6006 Harney, St. Louis 30, Mo.

**BUILD-it-yourself kits for bench saws, bandsaws, belt sander.** Hand tools only needed. Catalog free. Gillson Power Tools, Lambert Field, St. Louis 21, Mo.

**BUILD Copyrighted concrete block duplex \$1200.** Livingroom, kitchenette, bedroom, bath, each side. Full size blueprint, instructions, material cost list \$1.00. Information free. Batley Builders, 915 Pyramid Building, Little Rock, Arkansas.

**WOODTURNERS.** Schools. Six beautiful designed turned clock projects plans. \$1.00 postpaid. Clock Movements, Clocks, 115-16th St., Great Falls, Montana.

**BUILD Automatic clothes dryer.** Complete plans \$1.00. Nunsley Enterprises, 3380 Willey, San Leandro 2, California.

**BUILD Beautiful folding coffee table.** Full size plans and steel folding mechanism \$2.75. Free photograph. Vavrik Industries, Rossford, Ohio.

**RUSTIC Ornamental iron.** Make your own railings, hinges, pots, decorative metal pieces. Liquid metal—Brush it on wood, aluminum or metal. Will not rust. Send \$2.45. Atech Supply Co., 3840 Lagrange St., Toledo, Ohio.

**YOUR Workshop incomplete** without Easy Plater. Free catalogue, booklet. Easy Plater, Box 293 PM7, Red Lion, Penna.

**GRANDFATHER Clock easily built.** Big savings. See ad on page 285.

**MAKE Your own stone-veneer.** Economical, easily made, quickly applied. Looks like genuine stone. Formulas, illustrations, patterns \$1.00. Alburg, Box 17, Carrollton, Mich.

**CONCRETE Block homes.** 32 page booklet on how to build. \$1.00. H. C. Lightfoot, Civil Engineer, Richboro 1, Penna.

**BUILD A treasure and metal detector.** Lightweight, sensitive, inexpensive. Complete kits, free literature. Dept. 1, Electronic Applications, Box 4973, Washington 8, D. C.

**BUILD Your own tractor.** Free information. Eitrico, D-I, Camptonville, California.

### WATCHES, OLD GOLD, JEWELRY

**WATCH** And clock repairing books for hobbyists. Free information. North American, Dept. 14-B, 2320 N. Milwaukee, Chicago 47, Illinois.

**RHINESTONES.** Jewelry settings, combs, sequins, beads. Send 10c for illustrated catalog. J & M Novelties, Dept. CB-3, Griffith, Ind.

**FIX Watches** for pay or pastime. Free sample lesson. Chicago School, Dept. PM-2, 2330 Milwaukee Ave., Chicago 41, Ill.

**HIGHEST Cash paid** for old gold, broken jewelry, gold teeth, watches, diamonds, silverware, spectacles, platinum. Free information. Satisfaction guaranteed. Rose Smelting Company, 28-A East Madison, Chicago.

**WATCHES.** Wholesale catalog 10c. Kavanagh, 607 Knickerbocker Ave., Brooklyn 21, N. Y.

**CUCKOO Clock repair.** Beach's Clinic, 4055 S.E. Taylor, Portland 15, Ore.

**5000 JEWELRY Styles** you can easily make yourself. Rhinestones, pins, earrings, etc. Lowest prices guaranteed. Instructions and catalog 10c. Barry's, 165 Ardley Court, Newark, N. J.

**WATCHMAKERS'—Jewelers' complete** informative catalogue 25c. Bengale Company, Culver City, California.

**JEWELRY Making** can be a profitable hobby—Send 20c for our latest illustrated catalog. Milady-Fair Co., G.P.O. Box 1328, New York City.

### TOBACCO, SMOKERS' SUPPLIES

**PIPES Repaired—Expert craftsmanship,** work guaranteed. Briar pipes, vulcanite stems, \$1.75. Free estimates. Fred Diebel, Pipe-Lighter Service, 103 East 11th, Kansas City, Mo.

### RAZORS, BLADES, SHARPENING

**SENSATIONAL Blade offer.** 100 double edge blades, guaranteed, \$1.00 postpaid. Agent's offer with order. Merchandise Mart, Nottsville, Ala.

**HUNDRED Blades** seventy-five cents. Hornsby, Box 122, Washington 3, D. C.

### FOR THE HOME

**HEAT Homes** efficiently. Prints marked, bill of material listed. Details free. Garver Company, Vermont, Ohio.

**FOAM Rubber furniture cushions.** Factory seconds. 50% discount. Prices free. Perma-Foam, 140-C Main Street, East Orange, New Jersey.

### OF INTEREST TO WOMEN

**COMPLETE Quality line artificial** florist supplies. Woodfibre, leaves, centers, novelties. Catalog 10c. Profitcrafts, 4210321 Lorain, Cleveland 2, Ohio.

**DISTINCTIVE Wood gifts.** Catalog 10c. Wood Hut, Three Lakes, Wisconsin.

**GROW Mushrooms.** Cellar, shed, and outdoors. Spore, full time, year round. We pay \$3.50 lb. We paid Habbit \$4,185.00 in few weeks. Free book. Washington Mushroom Ind., Dept. 178, 2954 Admiral Way, Seattle, Washington.

**MAKE Big money** at home! Invisible reweaving pays \$10.00 profit an hour spare time. Make tears, cuts, holes disappear from fabrics. Constant demand from laundries, cleaners, homes assures steady earnings. Details free. Fabricon, Dept. C, 8342 S. Prairie, Chicago 18, Ill.

**NYLONS 8c Pair,** anklets 12c pair, socks 9c, print 17c, panties 12c, dresses \$1.95, slips 47c, undershirts 17c, rugs 70c, robes \$1.65, spreads \$2.65, \$70.00 watches—\$18.95, jewelry sets \$1.25, pens 8c, combs 1c, aspirin \$1.00-1,000 brushes 9c, razor blades 5-9c, electric razors \$2.00. Complete stock list, picture catalogue, 25c if sent immediately. Sibert's, Chattanooga 4, Tenn.

**GOOD Money** in weaving. Weave rugs at home for neighbors on \$69.50 Union Loom. Thousands doing it. Booklet free. Union Looms, 153 Post St., Boonville, N. Y.

**PROFITABLE Home business.** Make fast-seller chenille monkey trees, dolls, flowers. Terrific holiday demand. Information free. Velva, Bohemia 18, N. Y.

### FOR SALE—MISCELLANEOUS

**BOY Scout hand axe** \$1. Has history handle. Manufacturer overstocked. Haycliff Co., Huntington, Indiana.

**NEW—Never before** used pneumatic tree pruners. Well-built aluminum construction. Prepaid: 5 foot, \$17.50, 10 foot, \$21.50. Literature free. Kenrac Co., Box 373, Kent, Ohio.

**WORK Clothes.** Used, professionally laundered; coveralls, \$1.75; pants, \$1.25; shirts, 75c. Send cash, check or money order; indicate sizes. Plymouth Surplus Sales, Gloverville, N. Y. Add 50c postage and handling. Satisfaction guaranteed.

### WANTED—MISCELLANEOUS

**SCRAP Mercury (quicksilver)** containers supplied—Tantalum, bismuth, tungsten. Metallurgical Products Company, Established 1899, 35th and Moore Sts., Philadelphia 45, Penna.

OLD Trick penny banks. Big prices paid. Gordon Grimes, 2000 Marber, Long Beach 15, California.

QUICKSILVER, Platinum, silver, diamonds, indium. Write. Wholesale Terminal, Norwood, Massachusetts.

### PERSONAL

**BORROWING** By mail. Loans \$50 to \$600 to employed men and women. Easy, quick. Completely confidential. No endossers. Repay in convenient monthly payments. Details free in plain envelope. Give occupation. State Finance Co., 323 Securities Bldg., Dept. M-14, Omaha 3, Nebraska.

AUSTRALIA Remail airmail \$1.00. Kangaroo rugs, tanned, cured \$30.00. Campbell-Hicks, Condobolin, N.S.W., Australia.

SEATTLE Remails 25c. Forwarding service. Capps, 2640 South 183 Street, Seattle 24, Washington.

LETTERS Remailed 25c. Receiving-forwarding service. Hughes, 3900 21st St., N. E., Washington 18, D. C.

NEW YORK City—Letters remailed 25c each. Bonomo, 34 Jefferson St., Brooklyn 8, New York.

SANTA Barbara, Santa Ynez or Solvang remail. 25c each. Send to Chan-Co, Solvang, California.

BIBLE Reveals time of end. Free. Write: Harvest, Jefferson City, Missouri.

MIAMI Letter remailed 25c; local classified Sunday pages airmailed \$1.00. Six postcards \$1.00; we send cards, you address and return, we remail. Miami Mail, Box 368, Miami 33, Fla.

NEW YORK, Philadelphia classifieds 50c. remails 25c. Fahrman, 335N Penn, Allentown, Penna.

GLOBAL Viewcard selection; worldwide remailing. Travelpost, Box 378, Jacumba, California.

PALM Springs! Fabulous desert resort! Stamped letters remailed 25c. Snyder, 1361 Camino Anapola, Palm Springs, Calif.

ATLANTIC City remailing, 10 beautiful postals \$1.00. Letters 25c. 14 B, Georgia, Atlantic City, N. J.

REMAIL 25c From Nassau, Habana, Cuba, 50c each. Pronto Service, P.O. Box 118, Miami Beach, Fla.

MINIATURES In oil colors from your favorite photos. Free details. The Mito Studio, Thomaston, Conn.

LETTERS Remailed 25c each. Private Pronto Service, P. O. Box 118, Miami Beach, Fla.

FRANCE—Will perform your interesting projects. R. Davis, 48 Rue Leterat, Chateauroux-Indre, France.

REMAIL, Receiving, personal services. Sixth year. Crown, Box 7041, Kansas City 13, Missouri.

SALT Lake City, Utah, postmark. Letters remailed (stamped) 25c each. Local reporting reasonable rates. Payne, Box 1341, Salt Lake City, Utah.

SAN Juan, Puerto Rico, Miami, Florida, New York City. Remails 25c each. Maditt, Box 613, Wantagh, N. Y.

JACKSONVILLE, Florida, letters remailed 25c. Minor services performed. Harris, 9534-P Lemturner, Jacksonville 8, Fla.

SOUTH America letters remailed airmail \$1. Roberts, Apartado 4374, Oficina Esle, Caracas, Venezuela.

LETTERS Remailed, received-forwarded, 25c. Convert, Box 109, Syracuse 1, N. Y.

MEMPHIS, Tenn. remails 25c, other services \$1.00. Security Co., Sterick Bldg.

IMPRESS Your friends. Ten beautiful postcards of Notre Dame University. You address and return. We remail here. Send one dollar to Remail, 1631 Lincoln Way East, South Bend, Ind.

LETTERS Remailed 25c each, 5 scenic cards \$1. remailed free. Homer, 13247 Bayre, San Fernando, California.

MEXICAN Law. General Practice Attorney, 1203 Arizona St., El Paso, Texas.

MIAMI, Miami Beach: Letter remailed 25c; local classified pages airmailed \$1.00. Confidential. Box 306, Miami 3, Fla.

LETTERS Remailed 25c. Personal address service available. Write for rates. McLaughlin, 800 Stewart, Columbus 8, O.

LETTERS Remailed 25c. Private receiving-forwarding address available. Hicks Service, 3216 Just Street, N.E. 303, Washington 19, D. C.

### MISCELLANEOUS

**LEATHERCRAFT**, Everything needed by beginners, advanced hobbyists and professional leatherworkers. Largest stock of supplies in U. S. Moderate-priced tooling leathers, top quality cutskins, tools, supplies, kits. Send 10c for big catalog. J. C. Larson Co., 320 S. Tripp, Dept. 3651, Chicago 24.

**BOY** Nationally advertised merchandise at tremendous discounts. A postcard brings free catalog. Fleming's Quality Merchandise, Box 5233M, St. Louis 16, Mo.

**HAIRCUT** As you like it. Booklet explains. 25c. Mastrolia, 32-20E2 80th Street, Jackson Heights 69, New York.

**BUY** At big discount. Free details. Hamnath Buying Service, Box 598, Madisonville, Tenn.

**BUY** Wholesale thousands nationally advertised products at big discount. Free "wholesale plan." American Buyers, 631-DD Linden, Buffalo, N. Y.

**OVER 2500** Uses. Sobo, king of all adhesives; non-inflammable, odorless. Sobo makes it possible to discontinue using inflammable and messy cements, glues and pastes. If your dealer is out of Sobo, send \$1.00. Glomans, 31-A Thomson, L. J. City, N. Y.

**12 NEW** Towels, large size, \$1.00. Assorted colors. New, not seconds. Money-back guarantee. Order now. Supply limited. Towel Shop, Dept. 150, Box 881, St. Louis, Mo.

**YOU** Can save \$2,514.00 on your present mortgage! And obtain a \$3,000 attic flat at no cost! Handbook gives you actual case history. See picture Home-A-Minute kit display ad this issue. Handbook price \$3.95 post. Free literature. R. J. Hall & Co., Dept. C, 3824 W. Roosevelt Dr., Milwaukee 16, Wis.

**PANNING** Gold—Free lesson; catalogue of mining, mineral books, supplies. Old Prospector, Box 728D1, Lodi, Calif.

**FREE 1954** Catalog on government surplus bargains from country's largest surplus organization specializing in outdoor, sporting goods, clothing, camping equipment, tents, rubber boots, tarpsulines, swim fins, hundreds of other items. Rockaway Sales Co., Dept. PM, Route 46, Rockaway, New Jersey.

**MAGNETS**—Permanent alnico. Never loses magnetism. Many uses. Excellent for map, bulletin work. No. 3. 12 for \$1.00. No. 5 stronger (not holder magnets) 8 for \$1.00. Quantity prices. Pritt Co., Dept. MM-2, 12 West 29th, New York City.

"**MIRACLE** Mind." Acquire mind of genius. Details 10c. Ketchikan Institute, 1913 Lincoln-Park-West, Dept. MP-2, Chicago 14.

**PROSPERITY** Through release of atomic mind power! Free booklet. Occomar, 90 West Broadway, New York City 7.

**SOUTHERN** Comfort for outdoor workmen with cold feet. \$15.95 buys zipper, sheep-lined articles. Brown and full sizes only. Supply limited. Repeat Sales, Dept. 10, Box 2395, Hiller Station, Buffalo, N. Y.

**RECEIVE** Magazines, samples, catalogues. Mails from everywhere. Offers, hundreds. Get listed 25c. Borick, Box 86, Cincinnati 26, Ohio.

**DRAWINGS**, Specifications to assemble treasure-mineral detector, \$3.95. Proven, patented instrument. Industrial Patent Reports, Box 6296, Washington 15, D. C.

**SURPRISE** Package. Worthwhile, interesting, unusual. 25c. Don Sappow, Blackwood, N. J.

**BE** Funny like "top" comedians! Photo-illustrated book shows you how. Reveals professional secrets. Plus 10 comedy scripts. \$1.50. Publisher, 4932 Eighth, Philadelphia.

**LABELS**, Small cartons, price list 10c. Smith's Labels, Box 8572, Los Angeles 33.

**NEW** Aircraft safety belts \$2.50 ea.; new rivet set kits, complete \$3.95 set; auto spark plugs, heavy duty, 14mm and 18mm \$16 per hundred. Lethee Supply Co., Selma, California.

**BUY** Wholesale cameras, appliances, gift ware, Catalogue 50c (refundable). Dart, 3612 E. Atlantic Avenue, Brooklyn 24, N. Y.

**SENSATIONAL** Towel sale. Twelve for \$1.00. Large but slightly irregular. Guaranteed. Wonderful for shop, garage, home. General Textiles, 8525 Euclid, Cleveland 3, Ohio.

**GRANIUM**, Big samples. Radioactivity guaranteed. One dollar. No stamps. WRB, Alameda, New Mexico.

**GOLDEN** Rays process kits, ingenious, genuine raised letter printing, writing, stamping. Sample kit \$1.00. Mack Distrib., Box 5187-PM, St. Louis 10, Mo.

**OROW** Mushrooms. Cellar, shed, and outdoors. Spare, full time, year round. We pay \$3.50 lb. We paid Habbitt \$4,185.00 in few weeks. Free book. Washington Mushroom Ind., Dept. 175, 2954 Admiral Way, Seattle, Washington.

**SEPTIC** Tank, outdoor toilet cleaner. Forget disposal worries. One Peptank treatment flushed into toilet monthly unclogs pipes, reduces mass and odor. Harmless to plumbing and fields. Trial supply, \$1.25. Year's supply, \$2.50. Postpaid. American Chemical Supply Company, Dept. J, 532 North 18th Street, Richmond 21, Virginia.

**INCREDIBLE!** Become mental superman overnight! Free booklet! Bijou, Box 1727-ME, Hollywood 28, California.

**OUTDOOR** Toilets, cesspools, septic tanks cleaned, deodorized with amazing, safe, harmless powder. Easy, economical to use. Saves digging, pumping. 150,000 customers guarantee satisfaction. Details free. Bureau Laboratories, Dept. O-36, Chicago 22, Illinois.

**CLEAN** Your three piece living room set for \$2.95. Easy. Money back guarantee. Rayko, 2628 Madison, Granite City, Ill.

**FAMOUS** Model power mower. Assemble your own power mower, gasoline or electric. Now available in low-priced parts kit—Exact duplicate of models of famous make mower. Thousands sold at \$119.75. Trains laws to carpet smoothness, yet sturdy enough to cut 10-foot growth of weeds or brush. No special tools required. This enjoyable home project can save you real dollars. Write for complete information! 7528 Oakwood, Rt. 1, Omaha, Nebraska.

**BE** The Popular Mechanics representative in your neighborhood and earn big profits in your spare time. Write Popular Mechanics Magazine, Room 406M, 200 E. Ontario St., Chicago, Ill.

**CIGARETTES**—Roll 200 mild, tasty, guaranteed to please for 75c. Details free. Pete Moberly, Box 451, Owensboro, Ky.

"**SQUEESIT**" Catsup dispenser. Unbreakable, washable. Shape of tomato. Holds full catsup bottle. \$1.10. Iwashko Company, Box 41A, Poughkeepsie, N. Y.

**300** BIG Mails guaranteed. Samples, plans, offers, propositions, 12 months listing. \$1.00 refundable. Wright Publications, 2270 Hubbard, Memphis 8, Tenn.

**SELECTIVE** Metal and mineral detector. Revolutionary design. Distinguishes metals from black magnetic sands. Readily detects metals under salt water. Also Geiger counters. Free literature. Gardiner Electronics Company, 2018 N. Dayton, Phoenix, Arizona.

**TREASURE** Finders for gold, silver and minerals. Money back guarantee, best available. Also Geiger counters for uranium prospectors, free information. Write Goldak Company, 1341 West Glencoka, Glendale 1, Calif.

**300** PROJECTS You can make—in Popular Mechanics 52-page Blueprint catalog. Send 3c stamp for copy. Popular Mechanics Press, Dept. 106, 200 East Ontario St., Chicago 11, Ill.

**STUDY** For game warden, park, fish, forestry, lookout, guide, wildlife conservation, immigration and highway patrol service. Details free. Write Deemer Institute, Co. Whittier, Calif.

**TREASURE**—M-Scope Geiger counters, mineral locators. Why buy something inferior when you can buy the best at a lower price? Backed by years of experience. Fully guaranteed by factory. Detects minerals, metals, gold, silver, coins. Payment plan available. Proven superior performance. Free 18 page illustrated booklet. Fisher Research Lab., Inc., Palo Alto, California.

**CLOGGED** Drains opened by new powerful chemical called Bursolvent. Removes grease, soap, tree roots, etc., without expensive digging and electric rodding machines. Simple to use. Mix with water and pour down sink. Postal brings free details. Electric Sewer Cleaning Co., Allston 34, Mass.

**GOLD, Silver, metal detectors**. Geiger counters for uranium. Mineralights. Sensational new fully guaranteed models. None finer. Information free. Detelectron Co., 5420 Vineland Ave., North Hollywood, California.

**GOLD, Silver, metal detectors**. Geiger counters for uranium. Mineralights. Sensational new fully guaranteed models. None finer. Information free. Detelectron Co., 5420 Vineland Ave., North Hollywood, California.

**GOLD, Silver, metal detectors**. Geiger counters for uranium. Mineralights. Sensational new fully guaranteed models. None finer. Information free. Detelectron Co., 5420 Vineland Ave., North Hollywood, California.

**GOLD, Silver, metal detectors**. Geiger counters for uranium. Mineralights. Sensational new fully guaranteed models. None finer. Information free. Detelectron Co., 5420 Vineland Ave., North Hollywood, California.

**GOLD, Silver, metal detectors**. Geiger counters for uranium. Mineralights. Sensational new fully guaranteed models. None finer. Information free. Detelectron Co., 5420 Vineland Ave., North Hollywood, California.

**GOLD, Silver, metal detectors**. Geiger counters for uranium. Mineralights. Sensational new fully guaranteed models. None finer. Information free. Detelectron Co., 5420 Vineland Ave., North Hollywood, California.

**GOLD, Silver, metal detectors**. Geiger counters for uranium. Mineralights. Sensational new fully guaranteed models. None finer. Information free. Detelectron Co., 5420 Vineland Ave., North Hollywood, California.

**GOLD, Silver, metal detectors**. Geiger counters for uranium. Mineralights. Sensational new fully guaranteed models. None finer. Information free. Detelectron Co., 5420 Vineland Ave., North Hollywood, California.

**GOLD, Silver, metal detectors**. Geiger counters for uranium. Mineralights. Sensational new fully guaranteed models. None finer. Information free. Detelectron Co., 5420 Vineland Ave., North Hollywood, California.

**GOLD, Silver, metal detectors**. Geiger counters for uranium. Mineralights. Sensational new fully guaranteed models. None finer. Information free. Detelectron Co., 5420 Vineland Ave., North Hollywood, California.

**GOLD, Silver, metal detectors**. Geiger counters for uranium. Mineralights. Sensational new fully guaranteed models. None finer. Information free. Detelectron Co., 5420 Vineland Ave., North Hollywood, California.

**GOLD, Silver, metal detectors**. Geiger counters for uranium. Mineralights. Sensational new fully guaranteed models. None finer. Information free. Detelectron Co., 5420 Vineland Ave., North Hollywood, California.

**GOLD, Silver, metal detectors**. Geiger counters for uranium. Mineralights. Sensational new fully guaranteed models. None finer. Information free. Detelectron Co., 5420 Vineland Ave., North Hollywood, California.

# YOUR OWN BUSINESS



EARN BIG PROFITS



WITH

# Sani-Serv

Continuous Direct Draw Dairy Freezer

Now's the time to take advantage of the ever-growing national demand for freezer-fresh soft ice cream products. Get your share of BIG profits with SANI-SERV, America's foremost continuous direct draw dairy freezer! Sell delicious frozen custards, soft ice cream, ice milk and other frosted favorites.

Operation is simple—no electronic gadgets to fool with—SANI-SERV makes and dispenses your frozen products for you.

No royalties—No red tape—You make daily profits while using the "Pay As You Grow" SANI-SERV plan. If you want big independent income, this is it! Mail coupon for full information on SANI-SERV's plan and request the free booklet "Blueprint for Success." There is absolutely no obligation.

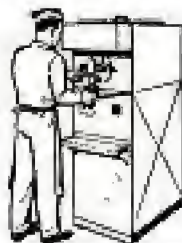

GENERAL EQUIPMENT SALES, INC.  
1348 STADIUM DRIVE, INDIANAPOLIS, IND.

Yes! Send me "Blueprint for Success" and information on the SANI-SERV plan.

Name: \_\_\_\_\_

Address: \_\_\_\_\_

City: \_\_\_\_\_ State: \_\_\_\_\_

PM-100



## Tiny Telescope

ACTUAL SIZE PHOTO

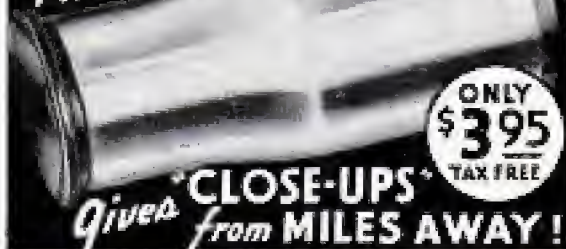

ONLY \$3.95 TAX FREE

Gives "CLOSE-UPS" from MILES AWAY!

A Powerful telescope yet the size of your thumb! Conceals completely inside palm of hand! A revolutionary German made optical achievement. Precision easy-slide operation. Scientifically ground lens provide Brilliant Illumination, sharp detailed images. Lustrous ALL CHROME with brass trim. An all purpose performer . . . instant focusing from 2 feet to infinity! NOT A TOY!

No Risk TRIAL OFFER

If not 100% satisfied after 10 Day Trial return for full refund. Cash orders \$3.95, postpaid, U.S.D. \$4.25. UNITED BINOCULAR CO., 8043 S. Western, Dept. PM-101, Chicago 20.

## SPORT AND PROFESSIONAL DIVING EQUIPMENT



"IF IT'S FOR DIVING DESCO MAKES IT!"

WORLD'S LARGEST MANUFACTURER OF DIVING EQUIPMENT. LITERATURE ON REQUEST.

DIVING EQUIPMENT & SUPPLY CO. Dept. P, 234 N. Broadway Milwaukee 2, Wis.

## Build your own JET ENGINE!



SEND NO MONEY

Order these plans today

1. JET PROPELLED BICYCLE. Assemble your own. Plans and instructions \$1.00.
2. HOW TO MAKE EXPERIMENTAL JET ENGINES. Seven sheets drawings with information and instructions \$2.95.
3. BOTH OF ABOVE in one order \$3.75. SEND NO MONEY. Order both at once \$3.35 C.O.D. in USA plus C.O.D. postage. Send check or money order and we pay postage. Get other information too. Rush Order.

J. HOUSTON MAUPIN, Dept. 55, Tipp City, Ohio

## Learn DRAFTING At Home

Tremendous opportunities in this field. Our simplified method trains you for well paying positions. Text books, drafting outfit, and instruments furnished. 3 courses in use. Low tuition. Free information.

ROTH TECHNICAL INSTITUTE

Dept. M2, Box 2282 Youngstown, Ohio

### Drop a Line to

Ask for your copy of Hildebrandt's Hints . . . tells about spinners and flies and how to use 'em for all kinds of fishing. Good advice from folks who know. Not a dry line in it. Your copy FREE. Address —

**HILDEBRANDT**  
LOGANSPORT 23 High St. INDIANA.



With a MONOGRAM Speedee-Bilt Kit

BUILD A FAMOUS BOMBER



Completely Finished Balsa and Plastic Parts • Only \$2.95 Each

Easiest to build.

Give yourself a thrill fellow. Build one of these famous bombers with the finest model building kit you ever saw. Now twin-engine planes easier to build than single-engine jobs in the past. Prefabricated balsa fuselage—famous all-luxa Monofil wings, completely drilled—34 detailed molded plastic parts including prop and pilots. In each kit,

The B-25 Mitchell built by Gen. "Jimmy" Doolittle and the B-26 Invader used in Korea. Famous planes with famous names. Get one for yourself. If no dealer near you order from address below. Each kit \$2.95, plus 35c for packing and shipping. Both kits for \$6.25 postpaid. You save 35c.

MONOGRAM MODELS, Dept. 12, 3421 W. 48th Place, Chicago 32

# New Amazing Invention—"Magic Art Reproducer"

# DRAW

# ANY PERSON IN ONE MINUTE

**NO LESSONS!  
NO TALENT!**

Anyone Can Draw  
With This Amazing  
New Invention—  
Instantly!



You Can Draw Your Family, Friends, Anything  
from REAL LIFE—Like An Artist Even if  
You CAN'T DRAW A Straight Line!

Yes, anyone from 5 to 80 can draw or sketch or paint anything now . . . the very first time you use the "Magic Art Reproducer" like a professional artist—no matter how "hopeless" you think you are! Anything you want to draw is automatically seen on any sheet of paper instantly! Then easily and quickly follow the lines of the "picture image" with your pencil . . . and you have an accurate original drawing that anyone would think an artist had done. Also make drawings larger or smaller as you wish. Anyone can use it on any desk, table, board, etc.—indoors or outdoors! No other lessons or practice or talent needed!

Also Excellent for  
Every Other Type  
of Drawing!

- Human Figures
- Outdoor Scenes, landscapes, buildings
- Still life, vases, bowls of fruit, lamps, furniture, all objects
- Copy photos, other pictures, portraits, etc.
- Copy blueprints, designs, decorations, for woodwork, machines, for needlework, crocheting, knitting
- Copy all cartoons.

Complete  
For Only **\$1.98**  
De Luxe  
Model

**HAVE FUN! BE POPULAR!** Everyone will ask you to draw them. You'll be in demand! After a short time you may find you can draw well without the "Magic Art Reproducer" because you have developed a "knack" and feeling artists have—which may lead to a good paying art career.

**SEND NO MONEY!  
Free 10-Day Trial!**

Just send name and address. Pay postman on delivery \$1.98 plus postage. Or send only \$1.98 with order and we pay postage. You must be convinced that you can draw anything like an artist, or return merchandise after 10-day trial and your money will be refunded.

**FREE!** "How to Easily  
Draw Artists'  
Models"

This valuable illustrated guide is yours free with order of "Magic Art Reproducer." Packed with pictures showing all the basic poses of artists' models with simple instruction for beginners of art. Includes guidance on anatomy, techniques and figure action.

Create Your Own Designs for All Hobbies! Reproduce anything!



Outdoor Scenes, landscapes, buildings.



**NORTON PRODUCTS, Dept. 5802K, 296 Broadway, New York 7, N. Y.**

## REAL ESTATE BE A BROKER

**PAYS BIG! SEND FOR FREE, BIG, ILLUSTRATED CATALOG NOW!** Graduates report making substantial incomes. Start and run your own business quickly. Men, women of all ages, learn easily. Course covers Sales, Property Management, Appraising, Loans, Mortgages, and related subjects. **STUDY AT HOME** or in classrooms in leading cities. Diploma awarded. Write TODAY for free book! No obligation. Approved for World War II and Korean Veterans. **WEAVER SCHOOL OF REAL ESTATE (Est. 1916)** Suite 300 Law Bldg. Dept. PMR Kansas City, Mo.

**FREE BOOK TELLS NOW**

**WHOLESALE Electric Guitars—Parts**  
Build Your Own  
Accordions, amplifiers, double-necks, triple-necks, pick-up mixes, mandolins, non-electric instruments, etc.  
**1954 MODELS WHOLESALE. FREE CATALOG**  
FREE home study course with instruments.  
Parts and plans available to build your own 4 or 8 string or multi-neck electric Guitar.  
Box 28 P.M. 2 Baldwin Park, Calif.

Say You Saw It in Popular Mechanics

## You're Right!

NOBODY LIKES TO ADD & SUBTRACT FRACTIONS

Get a **Fractionator**

**\$1.00**  
POSTPAID  
U.S.A.

Direct reading. Answers in fractions & Decimal Equivalents. 100% Accurate. Handles all Engineering Fractions.

Chas. E. Wells • Box 25-A • Montrose, Calif.

## OVERHAUL YOUR MOTOR in 10 minutes

**STOP BURNING OIL. STOP PISTON SLAP**

15,000 Mile Performance Guaranteed!

1st Step — CLEANSE WITH "MOTOR PURGE"—In the FIRST step of the famous

Motor Renew Kit treatment, the "Purge" formula cleans, quiete

and frees rings, valves and pistons from efficiency and power robbing carbon, gums and varnish. Pour this miracle solvent into the cylinders, run your motor and watch the combustion residue blow out of your exhaust pipe.

2nd Step—RENEW WITH "COMPRESSION SEAL"—RE-STORE COMPRESSION . . . GET NEW POWER, SPEED AND ECONOMY with "Compression Seal" As the SECOND step of the Renew treatment, sprays this self-expanding mineral compound into your cylinder where it can fill worn spots (which cause compression leaks) between cylinder walls and pistons. Thus it restores compression . . . cuts oil-con waste and eliminates costly engine overhaul and ring jobs.

100% MONEY BACK GUARANTEE!

Free Auto Manual with each order. Kit treats all cars and trucks.

\$6.95 Postpaid (or send \$1 deposit, bal. C.O.D.)

Electronic Developments, Dept. EM-2

30418 Venice Blvd. Culver City, Calif.

**WAR SURPLUS BARGAINS**

**WAR SURPLUS BARGAINS**

**\$500,000.00 INVENTORY for QUICK LIQUIDATION**

Surplus stocks—hundreds of them for home, shop, factory, farm and outdoor use. New items, used items, reconditioned items—all at tremendous savings—all priced for quick sale.

**Page After Page of Values**

This big catalog shows page after page of amazing money saving values. Write for your copy today. Send 10c in cover postage, mailing, etc. Write today! **SEND TODAY FOR YOUR COPY**

**10c**

**FIELD TELEGRAPH TRANSMITTER & RECEIVER SET**

Complete. Includes transmitter with pair of hand phones, sending telegraph key, buzzer, double-throw switch. Original cost of this instrument to English Government well over \$100.00. Ship. wt. 20 lbs. each. Allow sufficient postage or will be shipped express charges collect. Two 41 1/2 volt C batteries needed in each set. Batteries 45c each extra. Wire needed to connect for operation. No. 428. Complete set of two . . . **\$15.00**

One set . . . . . \$7.95

**STARK'S** 509 So. State St. Dept. PM-214 CHICAGO 5, ILL.

# CASH IN ON ROTO-SPLAY

ROTATING DISPLAY-TURNABLE  
OPERATES WITHOUT ELECTRICITY

• No Wiring • No Winding  
• No Fire Hazard

## "GOLDMINE FOR MEN WHO CALL ON MERCHANTS"

One of the fastest sellers ever to hit the U. S. So valuable Sears Roebuck bought for their own store use—no have Maxwell, Woodworth, Eastman Kodak. And no wonder! ROTO-SPLAY is a moving turntable that can be put in windows, on counters or shelves. No springs to get out of order. No cords or plugs, so it can be put anywhere for displaying merchandise. Think of it—8 weeks of MOVING DISPLAY for the cost of two 10c flashlight batteries. Most small merchants want two or three—big stores buy quantities at our low price! You can make \$10 to \$15 and up on every such sale. A fast working salesman should sell 30 to 40 a day! Merchants know that moving displays sell merchandise. So your sales are easy. Get the facts quick. Write at once and make a "clean-up" while you can be first. Facts are FREE. Send your name and address today—sure!



Sells for  
**\$9.95**

You Make as High  
as \$5.00 Each  
Runs Night and  
Day—5 to 8 Weeks  
on Two 10c Flash-  
light Batteries.

## MAXILUME COMPANY

125 W. HUBBARD ST. DEPT. R5-842 CHICAGO 10, ILL.

**SAVE \$65 ON THIS LUXURIOUS \$100 CONTOUR CHAIR 34.95 FOR**

Everything Needed Complete To Put It Together In One Evening

Scientifically correct design for restful, healthful, relaxing, adjusts for perfect sitting or reclining comfort. Proven beneficial to heart, nerves . . . most popular chair in the home. Firestone foam rubber and washable, pliable, genuine

Genuine FOAM RUBBER

Durban upholsters. Would cost \$100 or more in any store. Shipped all ready to put together in less than one evening by anyone who can use a screwdriver. No cutting, no drilling, no skill needed. A woman can do it. Order now! Everything needed for only \$34.95. T.N.S. Balto. State must warrant; forest green, sapphire, blue, lipstick red, walnut brown. Expires \$3 deposit, balance C.O.D. Money back guarantee. Return in 14 days. Order now. Bestcraft, Dept. 59, Mathieson Bldg., Baltimore 2, Md. *Save Money sitting and Assembling Contour Chairs for Friends*

## I'll Send You This Handsome SAMPLE CASE-FREE



and Show You How to Make  
Up to \$15.00 in a Day

Mail coupon for this Free Tailoring Sample Case packed with 150 beautiful, big-value suit and overcoat fabrics. Take orders from friends, fellow-workers, others, for fine quality, made-to-measure clothes. Pocket big cash profits in advance. Because wearing our suits and overcoats costs less money, we make it easy for you to get your own clothes without cost. No experience is needed. **SATISFACTION GUARANTEED.** SEND NO MONEY. Just fill out and mail coupon—today!

**STONE-FIELD CORP., 532 South Throop Street  
DEPT. G-816 CHICAGO 7, ILLINOIS**

**STONE-FIELD CORP., Dept. G-816  
532 S. Throop St., Chicago 7, Ill.**

Dear Sir: I WANT A MADE-TO-MEASURE SUIT TO WEAR AND SHOW, without paying for it. Book details and Sample Kit of actual fabrics, **ABSOLUTELY FREE.**

NAME \_\_\_\_\_ AGE \_\_\_\_\_  
ADDRESS \_\_\_\_\_  
CITY \_\_\_\_\_ STATE \_\_\_\_\_

# BUILD THIS HOUSE Yourself



Designed by Popular Mechanics  
and Famous Architects. Every  
Detail Simplified and Explained.  
No Previous Experience Needed!

Can you use everyday tools as well as the average Popular Mechanics reader? Then you, too, can easily build this modern house in any of its five designs. Doing every part of the job yourself. The new Popular Mechanics Book, "Your Home—How to Build It Yourself" will show you how.

### Space for Living and Family Growth

This beautiful, modern house is 1½ stories, with basement, living room, kitchen, dining nook, two bedrooms, bath, plenty of closets and space for two additional bedrooms on second floor. The house itself is 35' 9" x 28' 11"; breezeway 20' 10" x 12'; garage 20' 10" x 12'.

### The House That Has Everything

Designed for easy construction and the most living space for the least cost, the Build-It-Yourself House is also most attractive and suitable for any community and most income groups. The basic plan is adaptable to four other exterior designs.

### Get Book and Plans Now— Build When You Can

You may never have thought about actually building a house yourself, but now that building restrictions have been lifted, it is easier than you think. So order book and plans today. Even if you engage a contractor to build for you, you will need the plans. And you certainly will want the book which can easily save you hundreds of dollars, whether you build this or any other house.

## The Famous Popular Mechanics House

The picture below is from an actual photograph of the Build-It-Yourself House with breezeway and garage, as built by Jack Brownson, 23-year-old veteran, in Aurora, Illinois.

## Mail Coupon for New Book and Plans!

Build It Yourself  
or Have It Built  
—Save Hundreds  
of Dollars!

### PLANS YOU CAN READ AND FOLLOW

Plans consist of ten working-size blueprints—floor plans, elevations, construction notes, framing, joints, lumber and mill list, specifications, plumbing and wiring diagrams. Every measurement is marked—every detail made clear as ABC. Book has 100 pages—three-fifths are photographs and drawings. Some sections in color, showing just how your house will look when finished.

**BIG BOOK  
8½x11 inches**



## MAIL COUPON FOR BOOK AND PLANS

POPULAR MECHANICS PRESS, Dept. 16  
200 E. Ontario St., Chicago 11

I enclose \$\_\_\_\_\_ Send me the items checked at once.

- Your Home and How to Build It Yourself.....\$ 3.00  
 Complete set of plans for Popular Mechanics Home... 12.50  
 Book and plans at reduced price..... 14.00  
 Duplicate sets of plans..... 5.00

Name \_\_\_\_\_

Address \_\_\_\_\_

City \_\_\_\_\_ Zone \_\_\_\_\_ State \_\_\_\_\_

**Now YOU can PICK your JOB and BIG PAY Future in Allied's Nation-Wide Industrial Co-op Plan**

**INDUSTRY CRITICALLY NEEDS ALLIED TRAINED MEN TO FILL IMPORTANT JOBS**

- . TOOL ENGINEER
- . TOOL & DIE DESIGNER
- . MACHINE DESIGNER
- . MECHANICAL ENGINEER
- . DRAFTSMAN
- . MASTER MACHINIST
- . TOOL & DIE MAKER

**EARN YOUR BACHELOR'S DEGREE IN 31 MONTHS**

Shortages of Draftsmen, Designers, Tool Engineers, Machinists, Tool and Die makers are so widespread that you can pick a key job and look forward to rapid promotions, better pay, job security, success and achievement. Industry is expanding so rapidly that there are more good paying jobs than there are trained men to fill them.

Industrial Co-op program is integrated so that you can either study at home or at the Allied Institute's fully equipped shops and laboratories. You may enroll in short courses or study progressively for a Degree of Bachelor of Tool Engineering or Bachelor of Mechanical Engineering.

Allied is approved by Industry, the American Society of Tool Engineers, Department of Registration and Education, Department of Public Instruction, State of Illinois, Department of Justice for foreign Students, and the Veterans Administration. Accredited by Central Schools Assoc.

**ALLIED SCHOOL of MECHANICAL TRADES**

Allied Institute of Technology

1338-42 S. Michigan Ave. Dept. PM- 2 Chicago 5, Illinois

Gentlemen:

I want to get into important Industrial Trades and Professions.

Send me without obligation your FREE BOOKS explaining Allied's Courses of Instruction and information on Nation-Wide Industrial Co-op Plan.

I am interested in Resident Training  Home Study   
 I am eligible for the G. I. Bill  I am not eligible

Name \_\_\_\_\_

Address \_\_\_\_\_

City \_\_\_\_\_

State \_\_\_\_\_

send for **FREE BOOKS**

**ALLIED SCHOOL of Mechanical Trades**

1338-42 South Michigan Ave Chicago 5, Illinois

**BE YOUR OWN BOSS**

*Make Hundreds of \$ Spare or Full Time Work*

**NO EXPERIENCE NEEDED**

Here is the ideal business with no previous experience or large investment required and no high-priced equipment to buy. A business that will return dollars for the pennies you invest.

**YOU CAN CAST ANYTHING**

With Flexible Mold Making and Ornamental Casting, an amazing fact-packed book, you learn how you can cast practically any article in concrete, plaster, imitation marble or any other casting material using a marvelous new process. You can make ash trays, novelties, garden and lawn ornaments and hundreds of other highly profitable items that cost you but a few cents and sell for as much as \$5.00 and more. Why you can even make true-to-life full-sized busts of your neighbors and friends.

**NO EXPENSIVE MOLDS TO BUY**

Why buy high-priced molds from others? Learn how you can make your own molds quickly, easily and inexpensively with materials that can be used over and over. You get copyrighted formulas, complete instructions and detailed how-to-do-it photographs as well as complete sources of supply for the few inexpensive materials you need. This is the only book printed in America today that contains instructions for making profitable papier-mache casts.

**MONEY BACK GUARANTEE**

Start on your road to extra income and independence today. Send only \$3.00 for your copy of Flexible Mold Making and Ornamental Casting. Complete satisfaction guaranteed or your money refunded within seven days.

**POPULAR MECHANICS PRESS, Dept. 46**  
 200 E. ONTARIO ST., CHICAGO 11, ILL.

You can make simply and cheaply



**own your own business! earn up to \$75 A DAY CLEAR PROFIT in your back yard or basement!**

**MAKE CONCRETE BLOCKS With Amazing New LOW PRICED GENERAL BLOCK MACHINE**

**NOW! Big Building Boom Profits Within Your Reach**

You don't need much cash to cash in on the building boom! New high speed, low cost General Block Machine produces up to 1,000 concrete blocks a day for homes, factories, buildings, garages. Your profit markup is 100% to 150%! Foot-prot, easily operated, sturdy steel machine can make any size from 4" to 12". These superior 3-core blocks meet all building code requirements for foundation, chimney, eaves, sash and many other types of blocks. Works indoors or out. Sand, cement and water available anywhere! Simple operating instructions and mixing formulae for cement and cinder blocks supplied FREE. Get full details, no obligation!



R.L.T. of New York City Reports: "My General Block Machine PAID FOR ITSELF IN FIRST 2 WEEKS!"

Thousands now in use the world over! Write for FREE details TODAY

**EXTRA!**

Amazing illustrated book gives floor plans for 6 sensational concrete block bumpouts. Tells how to lay blocks, lay out building lines, mix concrete, build steps, porch and concrete floors all at great savings. Written by experts. Can save many times the cost of the machine! Get it now! No strings attached.

**HOW TO BUILD YOUR OWN CONCRETE BLOCK HOME**  
 Only 1.00 per copy

Book sent free if you buy machine. \$1 refunded if you buy later.

**GENERAL ENGINES COMPANY**

Dept. M-24, 307 HUNTER STREET, GLOUCESTER, N. J.

## Seltingen Steel HUNTING KNIFE



\$3.95

### MAKE THIS TEST!



Place a coin the size of a half dollar on some piece of thick cardboard. Place the point of the Black Forest Knife downward. The knife will completely pierce the thick coin — without ANY damage to the blade!

Low \$3.95 price (postpaid) means you'll have to act fast! Send \$3.95 in cash, check or p.o. for prompt delivery. CODs plus fees. Your money back quickly if you're not delighted!

THORESEN'S, Dept. 6-B-80, 352 Fourth Ave., New York 10, N. Y.

### DIRECT FROM GERMANY

The Black Forest Hunting Knife, made in Solingen, West Germany of superior Nickel Reshard (non-rusting) steel is NOW available in this country! The rugged beauty of this superb knife has already won recognition for Solingen in industrial circles on the Continent—and the utility and value as an aid in hunting & fishing has made it a prime favorite with sportsmen all over Europe! Blade is actually sharp enough to shave with; the genuine leather scabbard is metal-tipped; this knife will stand up against the most rugged treatment! 10 inches in length, sleek, graceful lines of this new German import make it an ideal collector's item—a hunter's delight—and a steady companion of men's deer decorations. Import supply is limited and the price is low! Act now!

## NEW way to enjoy SPORTS Movies, Plays, Nature, TV!

GET CLOSE-UP VIEWS ALL DAY WITHOUT FATIGUE!

Made in WEST GERMANY

Here for the first time—Germany's famed SPEKTOSCOPIES—a revolutionary concept in binoculars. Wear them like ordinary eyeglasses—hour after hour—without fatigue. Featherweight—only 1 oz. You'll hardly FEEL them! Yet here is a new, truly powerful optical design that gives you greater range than many expensive opera or field glasses and a far greater field of view than some selling for many times more! Has INDIVIDUAL eye focusing for clear, sharp viewing, whether you're looking at a play in the first row or a seashore some miles away! SPEKTOSCOPIES are ideal for indoors, outdoors or distant scenes or close-up viewing. Special low price—\$1.98, a saving of \$8.00 or more!

### Try at Our Risk — No Obligation!

Enjoy at our risk for 3 days. You must be delighted! Otherwise, your \$1.98 will be refunded with no questions asked! Limited supply forces us to place a limit of 2 per customer. Send check or m.o. for prompt, free delivery. COD's sent plus postage. Use convenient coupon below!

FAVORABLE EXCHANGE RATE MAKES THIS VALUE POSSIBLE! This is the first time this type of optical instrument has ever sold for less than \$10.00. The favorable rate of exchange and Germany's need for dollars make it possible. We're the exclusive distributors of SPEKTOSCOPIES in the U.S.A. Order today!

INTERNATIONAL BINGULAR CO., Dept. 6-B-90, 352 Fourth Ave., New York 10, N. Y.

Your Name \_\_\_\_\_  
Address \_\_\_\_\_  
Town \_\_\_\_\_ Zone \_\_\_\_\_ State \_\_\_\_\_



SPECIAL!  
198  
FTI

SAVE  
\$8

only  
1 oz.

## BE YOUR OWN BOSS

If you have \$3,000 to \$3,500 and would like to be in business for yourself, write, wire or call Tastee-Freez. OVER 800 SUCCESSFUL STORES now in operation EARNINGS LARGE.



TASTEE-FREEZ CORP. of AMERICA  
2518 W. Montrose, Dept. F, Chicago 18, Ill.

## RICH CARBURETOR ROBS MOTORIST



CAR owners who are wasting money, getting poor gas mileage due to over-rich mixtures, will be pleased to learn how to save gasoline by VACU-MATING OVER-RICH MIXTURES. Vacu-Matic fits all cars, trucks and tractors. Automatic and operates on the supercharge principle. Easily installed in a few minutes. SALEMEN WANTED! Big Profits

For FREE particulars, how you can install one on your own car for introducing, just send your name and address on a postcard to VACU-MATIC, 7617-2064 W. State St., WAUWATOSA, WIS.

## HELPFUL BOOKS

Send post card asking for FREE catalog  
Popular Mechanics Press, 200 E. Ontario, Dept. 601, Chicago 11

## Build this Beautiful LAWN FURNITURE YOURSELF

### NO EXPERIENCE NEEDED

Smart Exclusive Styles By John Bergson  
... Four Big Plans Drawn to Scale ...  
Complete Material List

Now with just a few spare time hours and some inexpensive materials you can build gay comfortable lawn furniture that will make your garden more attractive ... more comfortable and more fun this summer.

No need to pay a small fortune for lawn furniture when you can build your own and save over 50% of what it would cost you already built!

Popular Mechanics four big drawn-to-scale plans show every step to follow. Complete material list tells you just what sizes of wood to buy so there will be no waste.

Make your lawn and garden the finest and most attractive on your block by building this smartly styled furniture. Enjoy real comfort during those hot summer months by making your garden your outdoor living room. Send today for your plans and material list. Complete set of four plans only \$2.00. Complete satisfaction guaranteed or your money refunded.



PORCH CHAIR



SERVING CART



GARDEN LOUNGE



PICNIC TABLE



PORCH GLIDER



ADIRONDACK CHAIR

POPULAR MECHANICS PRESS  
200 E. Ontario St.  
Chicago 11



AMERICA'S GREATEST WATCH VALUE

# BULOVA 21 JEWEL

LOWEST PRICE IN HISTORY

**\$19.95**  
PLUS TAX

LIFETIME SERVICE GUARANTEE

WHY PAY  
~~\$71.50~~

SAVE \$51.55

FREE TRIAL OFFER

You can get the unredeemed service guaranteed Bulova Deluxe 21 Jewel movement in new latest style yellow-gold "His Excellency" case, at this never-before-possible low price because we bought out Christmas surplus stocks of leading jewelers. Order now and get your 21 Jewel "His Excellency" Bulova at only \$19.95 plus \$2 tax while these last. Free trial offer. Wear at our risk. Money back guarantee in 10 days if not delighted. Send only \$1 with order, pay balance C.O.D. plus postage. Or enclose \$19.95 plus \$2 tax.—We pay postage. Handsome expansion band free with order.

**Maryland Distributors, Dept. 616**  
501 East Baltimore St., Baltimore 3, Md.



HER  
**EXCELLENCY**  
**\$21.95** Plus \$2.20  
Fed. Tax

Write for free watch and diamond catalog. Practically wholesale prices.

## AUTO RACING BOOKS AT NEW LOW PRICE

**Automobile Racing — Fifth Edition by Roy F. Kuns.**

This is a book for auto racing fans. It covers construction and specifications of racing cars and tells and shows how you can build your own. It also contains regulations for midget auto racing and describes roadster racing in California. A number of Indianapolis races are described and pictured. Formerly \$1.00 per copy. Now just..... **50¢**

**Automobile Racing — Fourth Edition by Roy F. Kuns.**

Includes eight working drawings and complete building instructions for standard midget racers as well as drawings for midget road cars. Miller Ford V8 front-drive racers are illustrated and described and other big-time data given. Large, clear pictures give inside information. Was \$1.00—Now only **50¢**

POPULAR MECHANICS PRESS

300 E. Ontario St.  
Chicago 11, Ill.

## Heike's 1954 Hobby Catalog <sup>Only</sup> 35¢

GWOLTSCHUERBELLERAIKEN—Am selling several hundred historic and scientific items for collectors.—Some 500 historical firearms—20,000 Indian pre-historic relics—Collectors Cartridges—Coins—Confederate Money—Revolutionary, Civil War, Indian Wars, Flintlocks, Percussion Muskets, Rifles, Swords, Bayonets, Pistols, Revolvers, Raucods, Bullet Molds, Percussion Caps, Powder Flasks, Powderhorns, Blunderbusses, Civil War Band Grenades, — Stagecoach Carabines, Winchester, Kentucky Rifles, Pepperboxes, Derringers, Many exceedingly Rare guns, Gun Barrels, Nipples, FRONTIERS, Arrowheads, Tomahawks, Battle Axes, Metaloes, Manoes, Gampoints, Bird-joints, Spearheads, Bannestones, Gornets, Plummetts, Silver-Buffalo-Deer, Elk Horns—Eagle feathers, Bone-wood, Violin Wood, Mounted Birds, Pheasants, Quails, Squirrels, Deer-heads, Owls, Agates, Fossils, Minerals, Lapidary Supplies.—Dauguerotypes, Ambrotypes, Duelling pistols, Gold Dollars, Marine Shells, Etc., etc.



**SPECIAL:** —5 prehistoric arrowheads \$1.65—10 Indian-head Cents, 88¢—Prehistoric Tomahawk \$0.40—Prehistoric Hammerstone \$2.88—Bayonet \$1.98—Scalper \$2.88—Stone Pestle \$6.87—Agate, Fossil, Goode, Galena, Pools Gold, Sulfite, Molybdenum, Crinoid, Parlie, Gastropod, Jade, Azurite, Malachite, Ruby, each \$4.48—all 10 \$5.45.

Send 35¢ for profusely illustrated 1954 catalog (refundable).

**R. HEIKE, 24 M Street, WENONA, ILL.**

A FULL PAGE AD COULDN'T OFFER BETTER VALUE, MONTH AFTER MONTH — FOR YEARS, YOU SEE OUR AD. **FOOLISH TO PAY MORE—DANGEROUS TO PAY LESS**

FINERY USED **TIRES** NOT RECAPS  
U.S. Goodyear, Firestone and Others

**CAR \$3.50** 20 MO. GUAR. **TRUCK** SMALL 37 LARGE \$11

Not a life here, we wouldn't use ourselves.

**WORLD'S FAMOUS FINEST. 32 MO. GOLDEN RULE GUAR.**

600-16	\$5.05	650-15	\$5.38	700-15	\$4.75	750-20TK	\$11.80
600-16-0	8.68	650-15	4.44	700-15	4.80	750-20TK	19.32
650-16	8.48	670-15	4.35	700-15TK	8.75	900-20TK	17.34
650-16-0	8.75	710-15	5.30	700-17TK	8.85	1000-20TK	16.07
700-16	5.85	780-15	5.48	800-20TK	7.74	1100-20TK	16.32
700-16-0	8.95	800-15	5.78	850-20TK	9.43	1000-22TK	17.34
750-16	7.35	820-15	5.78	700-20TK	10.75	1100-22TK	16.48
850-17	4.15	WHITE WALLS	\$1.00 Extra	750-16TK	9.38		

**MUD-GRIP, MILITARY TREAD (Army Surplus)**  
750-20 20 Mo. Guar. Super \$8.50; 112 Mo. Guar. Sugged \$14.04  
900-16 20 Mo. Guar. Super \$8.80; 112 Mo. Guar. Sugged \$13.25

**BLATT PHILA., PA., 11th & SPRING GARDEN ST.** Send 35¢ or M.O. **ORDERS RUSHED**  
order from your nearest store **MIAMI, FLA., 2827 N.W. 7th AVE.**

## Learn the Secrets BREED RARE tropical fish



KIND OF FISH	EGGS OR YOUNG PRODUCED AT ONE BIRTH	APPROX. RETAIL PRICE OF FULL-GROWN FISH
Spotted	25 to 100	\$1.00 to \$1.00 Pr.
Blue Dots	75 to 100	2.00 to 4.00 Pr.
Red Dots	100 to 150	1.00 to 17.00 Pr.

## ... IN YOUR HOME... SPARE ROOM, BASEMENT, GARAGE... ANYWHERE! EARN BIG MONEY—SPARE TIME

New "Chance of Lifetime" opportunity! Start your own spare or full time business once you know the revealing breeding secrets. It's fascinating! It's Fun! Breed EXOTIC and graceful "Angel Fish", BEAUTIFUL "Gourami" that are 12 DIFFERENT COLORS, "Fighting Fish" THAT FIGHT UNTIL DEATH; "Danio" that are STRIPED LIKE A ZEBRA; TRANSPARENT FISH—hundreds of expensive varieties. Some fish lay 300 to 600 eggs at one time. (Some very rare fish have sold for over \$75 a pair.) Get into PARTNERSHIP WITH NATURE and let nature multiply your profits for you. NO EXPENSIVE EQUIPMENT—NO EXPERIENCE NECESSARY, WE SUPPLY EVERYTHING YOU NEED. HELP THE HUGE DEMAND from stores, offices, theaters, hotels, etc. New plan lets YOUR MAHMAN BRING YOU ORDERS. Investigate TODAY.

**FREE!** Catalog "How To Do It" success BOOK-LET, REPRINTS, breeding BROCHURE and ALL DETAILS. Rush coupon today!

## RUSH this Coupon TODAY!

Tropical Fish Breeders of America, Dept. D-2  
1018 S. Los Angeles St., Los Angeles 13, California

Dear Sir:

Please send me all Free Details.

Name \_\_\_\_\_

Address \_\_\_\_\_

City \_\_\_\_\_

State \_\_\_\_\_

Your Age \_\_\_\_\_

Get the Practical Help You Need With These

# POPULAR MECHANICS BOOKS

Use Them to Save Time and Money Make Extra Money Enjoy Hobbies and Pastimes Build Your Own Home Improve Farm Income Get the Most Out of Your Home Workshop Enjoy Better Living



You may examine any books that interest you. Full purchase price refunded on books returned in 7 days. Order by number in coupon below. All books are cloth bound and fully illustrated with photos, drawings, plans and working diagrams. Some in color. Only Popular Mechanics with 51 years of publishing experience and tremendous facilities can give you such practical and helpful how-to-do-it books so moderately priced. Order today. Prompt shipment and guaranteed delivery. Order by number in coupon below

## HOME SHOP

**SIXTY POWER TOOLS AND HOW TO BUILD THEM (1)** How to turn scrap and discarded materials into power tools at little cost. ....\$2.50

**POWER TOOLS AND HOW TO USE THEM (2)** Expert advice on selection and use of power tools for the home shop. ....\$2.50



**PLANNING YOUR HOME WORKSHOP (3)** The six basic power tools, floor plans, layouts, etc. ....\$2.50

**PORTABLE POWER TOOLS (4)** Practical information on the selection, care and use of portable power tools. ....\$2.00

**WELDING, BRAZING AND SOLDERING (5)** All the tricks and know-how of good soldering, welding, etc. ....\$1.75



## HOMES - BUILDING

**YOUR HOME AND HOW TO BUILD IT YOURSELF (6)** Investments of amateur builders have built this six room house themselves. ....\$3.00

**CONCRETE BLOCK HOUSE (7)** Built in many communities for less than \$4,000. ....\$2.00

**RANCH HOUSE BOOK (BUILD IT YOURSELF) (8)** Exciting new ranch type home with five or six rooms you can build yourself. ....\$3.50

**ROOF FRAMING (9)** The Poulsen method. Roof framing in one-fifth the time. ....\$3.00

**GUIDE TO HOME REPAIRS (10)** Money and time saving information for home owners. ....\$2.50

**HOW TO BUILD YOUR OWN GARAGE (11)** Popular Mechanics own collection of designs, plans and building information for amateur builders. ....\$3.50

**HOME PLUMBING GUIDE (12)** Approved methods, materials and how-to-do-it instructions. ....\$3.50

**LAWNS AND GARDENS (13)** How to grow the best lawns and gardens in any neighborhood. ....\$2.00

**HOW TO PAINT WITH BRUSH AND SPRAY (14)** Includes interior and exterior painting, walls, woodwork and furniture finishing. ....\$2.50

## AUTO BOOKS

**AUTO OWNERS MANUALS** By C. E. Parley. Cover all models from 1940 to 1953.

**MANUAL FOR PLYMOUTH OWNERS (15)** ...\$3.50

**MANUAL FOR CHEVROLET OWNERS (16)** ...\$3.50

**MANUAL FOR FORD OWNERS (17)** ...\$3.50

**MOTORISTS FIX-IT BOOK (18)** How to avert auto troubles; make simple repairs, do auto servicing at home. ....\$2.00

**POPULAR MECHANICS AUTO ALBUM (19)** Most fascinating of all auto books. From the first cars to the cars of tomorrow. ....\$3.00

## SAVE WITH THESE

**ALL ABOUT TELEVISION (20)** A new and timely money-saving book for the TV set owner. ....\$3.00

**RADIO, TV AND ELECTRONICS HANDBOOK (21)** Ideal book for the student, beginner and experimenter. ....\$2.50

**ALL ABOUT UPHOLSTERY (22)** How to do all types of upholstery and save 50% of the cost. ....\$3.50

**ELECTRICAL FIX-IT BOOK (23)** How to repair and service all types of electrical appliances. ....\$2.00

## WHAT TO MAKE

**WHAT TO MAKE AND HOW TO MAKE IT** Volumes 1 to 12. Available 175 projects to volume. Each. Give volume number with prefix (W3) ....\$1.75

**12 Volume set (24)** There are over 3,000 projects in this 12 volume set. Complete instructions for each. ....\$18.00

**1952 Volume (25)** ....\$2.00

**1953 Volume (26)** ....\$2.00

**WHAT TO MAKE FOR CHILDREN (27)** 175 projects—things to make from discarded and inexpensive materials. ....\$2.00

**100 BEST WOODWORKING PROJECTS (28)** Cream-of-the-crow projects. Selected by Popular Mechanics editors for their popularity. ....\$2.00

**100 BEAUTIFUL PIECES OF FURNITURE YOU CAN MAKE (29)** Real furniture projects for the craftsman with low tools. ....\$3.00

**23 BOATS YOU CAN BUILD (30)** Build a boat for pleasure or profit—row boat, sail boat, power craft. ....\$2.00

**YOU CAN MAKE A STRADIVARIUS VIOLIN (31)** Full set of actual size plans in pocket in the cover. ....\$3.50

**WHAT TO MAKE WITH CONCRETE (32)** Covers walks, walls, pools, fireplaces and ornamental garden pottery. ....\$2.00



## OUTDOORS - SPORTS

**OUTDOOR SPORTS MANUAL (33)** 200 helpful articles for hunters, fishermen, trappers, etc. Hundreds of ideas on fishing tackle, guns, traps, boats, insects, etc. ....\$2.00

**HOW TO TEMPT A FISH (34)** By Joe Godfrey, Jr. Complete fisherman's guide. Covers all types of fishing equipment and lures. Tells where and when to fish. ....\$2.00

**GUIDE TO GOOD HUNTING AND TRAPPING (35)** How, where and when to hunt all game animals. Special section on birds, guns and hunting dogs. ....\$3.00

## FOR GIFTS - FOR BETTER LIVING

**HOW TO BUILD AND ENJOY YOUR OWN OUTDOOR KITCHEN (36)** How to build and use outdoor living facilities. ....\$2.00

**FOOD FOR HOME USE (40)** How to produce and preserve food from farms and home gardens. ....\$3.00

**FIFTY YEARS OF POPULAR MECHANICS (41)** The fascinating story of invention, scientific discoveries and mechanical developments from the pages of



Popular Mechanics during its first 50 years. ....\$3.00

**ALBUM OF AVIATION (42)** A history of famous flights and flyers commemorating the anniversary of 50 years of powered flight. Hundreds of thrilling photographs and drawings. ....\$3.00

**PICTORIAL HISTORY OF AMERICAN TRANSPORTATION (43)** Fascinating gift book featuring 50 years of an America on the move. ....\$5.00

## FOR CHILDREN

**MR. WIZARD'S SCIENCE SECRETS (44)** By TV's famous Don Herbert. Collection of safe, simple experiments children can make at home. ....\$2.95

**BOY MECHANIC (45)** New edition with all new material. Hundreds of things a boy can easily make at home. ....\$2.95

**YOUNG CRAFTSMAN (46)** The book of useful pastimes—things to do and make for hours of all ages. ....\$2.00

## FOR FARMERS

**HOG PROFITS FOR FARMERS (47)** A "must" book for every hog producer. ....\$3.00

**FARM MANUAL (48)** A book every farm home should have. More than 150,000 sold to date. ....\$3.00

**VETERINARY GUIDE FOR FARMERS (49)** Enables farmers to perform most veterinary tasks. ....\$3.95



## USE THIS MONEY BACK ORDER COUPON

POPULAR MECHANICS PRESS, 200 E. Ontario St., Chicago 11, Ill.

Send Popular Mechanics books as indicated by numbers.

Number \_\_\_\_\_  
Number \_\_\_\_\_

Remittance for \$\_\_\_\_\_ enclosed. Send postpaid.

Send C.O.D. I will pay postman for books and delivery.

I understand I may return book within 7 days and you will refund the full purchase price. (Attach extra sheet to coupon if space is needed.)

Name \_\_\_\_\_

Address \_\_\_\_\_

City \_\_\_\_\_ Zone \_\_\_\_\_ State \_\_\_\_\_

**Girl with  
stapler beats  
girl with  
tape 4 to 1**



**... and cuts costs in half!**

This photo was snapped during a shirt-wrapping race between two girls at Kent Stores, the world's largest laundry and cleaners.

With a Bostitch stapling plier and paper bags, the girl at left was able to wrap 4 times faster, averaging better than 3 packages a minute.

The other girl wrapped with paper and tape, the method Kent discarded. For her to draw the tape, tear it, position it, and press it—while the first girl did the same fastening job with a simple click-click of the Bostitch stapling plier—was hardly a race at all! With a 4 to 1 speed advantage, the new wrapping method cut time-and-material costs in half.

Stapling is more secure, looks neater, is immune to heat and humidity. Usually the delivery slip is attached with one of the same staples that close the bag.

Over 800 kinds of Bostitch staplers trim time and costs on *thousands* of fastening jobs. To help you fit the right stapler to the job, 325 Bostitch Economy Men work out of 123 cities in the U. S. and Canada.

Check over your own fastening methods with your nearest Bostitch Economy Man. There's no obligation. He'll be glad to tell you honestly if and how stapling can save you money.

Look up "Bostitch" in your phone directory or write us.

**Fasten it better and faster with**



**BOSTITCH, 542 Mechanic St., Westerly, R. I.**

- Would like an Economy Man to analyze our fastening problems.
- Would like to have FREE BULLETIN telling how stapling can cut costs on fastening jobs checked below.

I want to fasten:

- |                                   |                                       |                                 |                                  |
|-----------------------------------|---------------------------------------|---------------------------------|----------------------------------|
| <input type="checkbox"/> packages | <input type="checkbox"/> plastics     | <input type="checkbox"/> wood   | <input type="checkbox"/> leather |
| <input type="checkbox"/> rubber   | <input type="checkbox"/> light metals | <input type="checkbox"/> fabric | <input type="checkbox"/> cartons |

Name \_\_\_\_\_

Company address \_\_\_\_\_

City \_\_\_\_\_ Zone \_\_\_\_\_ State \_\_\_\_\_

It's here...

*Fingertouch*

# Electric



**FREE!** Send for big new catalog of the complete Evinrude line for '54. Striking full-color action pictures of all models. Write for it today!

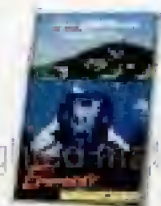

Copyrighted material

# Starting...

*on America's finest outboard motor!*

Skipper, step aboard! Slip behind the wheel... press the starter button... shift gears and streak away... *all without going near the motor!* Now a finger touch whirls your Big Twin to life, as easily and surely as starting your car. Now *full remote operation* becomes a reality! With Evinrude electric starting and Simplex controls you lounge in comfortable forward seat in complete command. You start your motor—choke it—shift it—"gun" it—troll it—idle it—all with finger tip ease! Anyone—your wife or youngster—*anyone* can start and run the new electric Big Twin.

Enthusiasts have looked forward to the time when electric starting would do for outboard boating what the electric starter did for the automobile. Now it's here—from Evinrude—giving you handling ease to match expensive inboard runabouts and cruisers—at *modest cost!*

**SEE YOUR EVINRUDE DEALER!** Look for his name under "Outboard Motors" in your phone book. See the complete line of Evinrudes for '54. **BIG TWIN**, 25 HP,\* in electric starting and standard models. *Super FASTWIN*, 15 HP, most versatile performer in its field. The revolutionary *FLEETWIN Aquasonic*, 7.5 HP, whisper quiet, smooth as sailing! *LIGHTWIN*, 3 HP, with famed Fisherman Drive. For free catalog write **EVINRUDE MOTORS**, 4277 N. 27th St., Milwaukee 16, Wisconsin.

IN CANADA, Mfd. by Evinrude Motors, Peterborough



\*All power ratings are O. B. C. certified brake HP at 4000 R.P.M.

# Evinrude **BIG TWIN**

*with Electric Starting*

Copyrighted material

# Chrome

is where  
the  
heart  
is!



Yes, the heart of any engine is the piston and rod assembly... and Perfect Circle's 2-in-1 chrome piston ring set gives complete protection against wear where the power is produced!

**No chrome** piston ring set can really give *complete* wear protection in the "heart of the engine" unless it provides a chrome-plated TOP ring, as well as a chrome-plated oil ring. For the top ring operates where heat is highest, pressure is greatest, and lubrication is poorest!

**That's why** Perfect Circle's 2-in-1 chrome piston ring set has established new standards of ring performance . . . why it seals compression and controls oil for *over twice as long as old style sets!* And only 2-in-1 furnishes an alternate HiPressure spring with each oil ring, for positive control even in badly worn engines!

Perfect Circle Corporation, Hagerstown, Indiana;  
The Perfect Circle Co., Ltd., Toronto, Ontario.

# Perfect Circle

PISTON RINGS • The Standard of Comparison

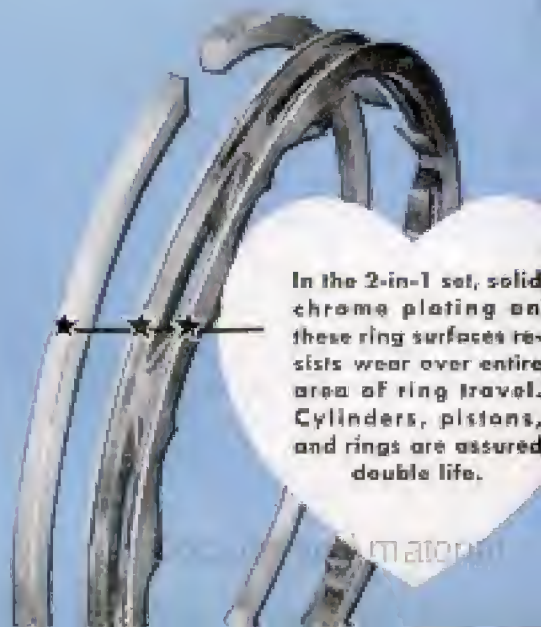

In the 2-in-1 set, solid chrome plating on these ring surfaces resists wear over entire area of ring travel. Cylinders, pistons, and rings are assured double life.

# POPULAR FEBRUARY 1954 MECHANICS

WRITTEN SO YOU CAN UNDERSTAND IT  
VOL. 101 NO. 2



North American Aviation photo

Dramatic night scene shows rocket engine being fired in horizontal position at test stand in California

## GUIDED MISSILES ON LEASH

*By Thomas E. Stimson, Jr.*

**R**OCKET MOTORS powerful enough to drive a space ship to the moon can receive their trial runs in some enormous test stands recently built into the side of a granite ridge near Edwards Air Force Base in California.

Moon rockets aren't contemplated this year or next, of course; the purpose of the new experimental rocket-engine test station is to proof-test the motors, fuel systems and other components of big guided missiles being developed for the Air Force.

"If a rocket motor goes bad after a missile is launched, there's no way of learning what caused the failure," explains Richard

F. Gompertz, chief of the Edwards Rocket Branch. "But if a new kind of motor malfunctions while it's on the test stand, the trouble can be found and corrected."

Today, the design and manufacture of guided missiles is one of the largest, and most secret, industries in the United States. The Army, Navy and Air Force are making expenditures at the rate of more than a billion dollars a year. The new Edwards installation is only one of more than a half dozen research centers including those at Banana River, Fla., Redstone Arsenal, Ala., Point Mugu and Inyokern, Calif., and White Sands, N. M.



Some of the rocket motors that are to be tested at Edwards are so powerful that extraordinary precautions must be taken against blast and possible explosion. Even the most ordinary of liquid rocket fuels have greater energy than TNT.

At Edwards, the main machine shops and laboratories are located in a "safe" area on the far side of some rolling hills that serve as a "generally safe" buffer zone. Small machine shops in the "very hazardous" area adjacent to the test stands have roof and wall panels that are attached to their steel frames by shear bolts. If a violent explosion from a test stand strips the roof and sides from a building the panels can be brought back and reattached to their frames.

In addition to sirens that warn research personnel when a firing is scheduled, traffic on the service roads is brought to a halt by barrier gates and by traffic lights.

The only people allowed in the "very hazardous" zone while a big motor is being tested are the technicians who are stationed inside a million-dollar control center that is partly buried in the rock between the two test stands. This building has thick reinforced double-concrete walls separated by an air space as a precaution against explosions that could level an ordinary structure. From inside the station you can watch a firing by means of periscopes that project through the roof, or from viewing ports that consist of five layers of armored glass separated by air spaces. During tests of a high-thrust motor these ports are covered by steel plates.

The test stands themselves project out from the top of the granite cliff. Below them are the concrete spillways that serve as flame deflectors and that also channel away any propellant that spills from a stand. When a rocket motor is to be fired it is mounted in a thrust cradle built into the stand. It can be turned to various angles to simulate various attitudes of flight. Fuel tanks for thousands of gallons of WALC (water alcohol), LOX (liquid oxygen) and other propellants are located in and behind the stands, as is a high-pressure water-deluge system that can flood a test stand if an uncontrolled fire breaks out.

Guided missiles comprise a large and diversified family of aerial "vehicles," not all of which are powered by rocket motors. Some are true rockets, some are actually pilotless high-speed aircraft powered by pulsejet, turbojet or ramjet engines. About the only things that all guided missiles have in common are a warhead and a robot-guidance system of some kind.

Powerful exhausts lift the Douglas Nike skyward in test firing. This missile is a surface-to-air type



## Four Basic Types Of Guided Missiles



**SURFACE-TO-SURFACE.** The Matador above may be fired from a roadable launcher as it needs no special launching equipment of permanent type. It is aimed at surface targets and uses a rocket for the take-off and turbojet engine in flight.

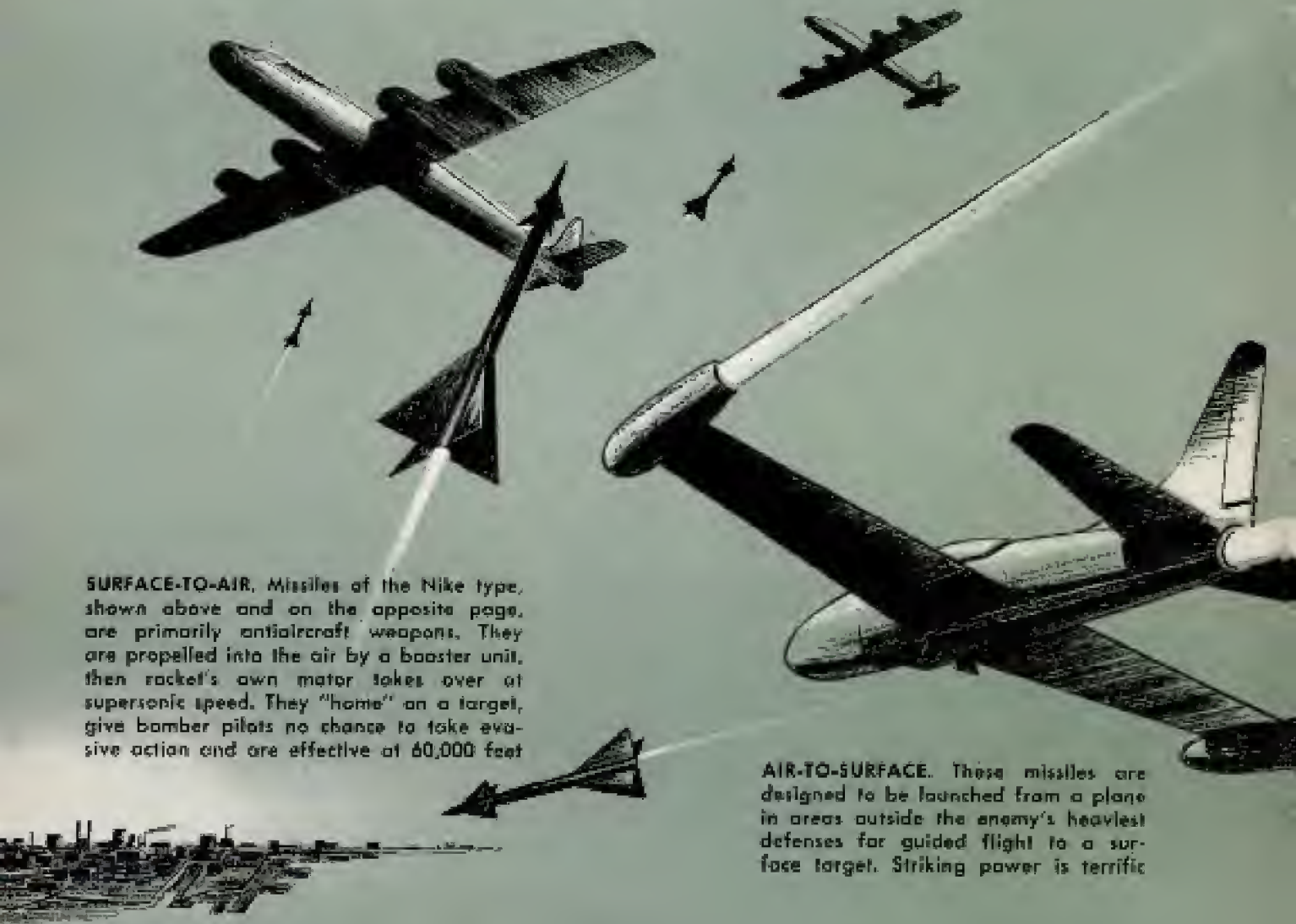

**SURFACE-TO-AIR.** Missiles of the Nike type, shown above and on the opposite page, are primarily antiaircraft weapons. They are propelled into the air by a booster unit, then rocket's own motor takes over at supersonic speed. They "home" on a target, give bomber pilots no chance to take evasive action and are effective at 60,000 feet.

**AIR-TO-SURFACE.** These missiles are designed to be launched from a plane in areas outside the enemy's heaviest defenses for guided flight to a surface target. Striking power is terrific.

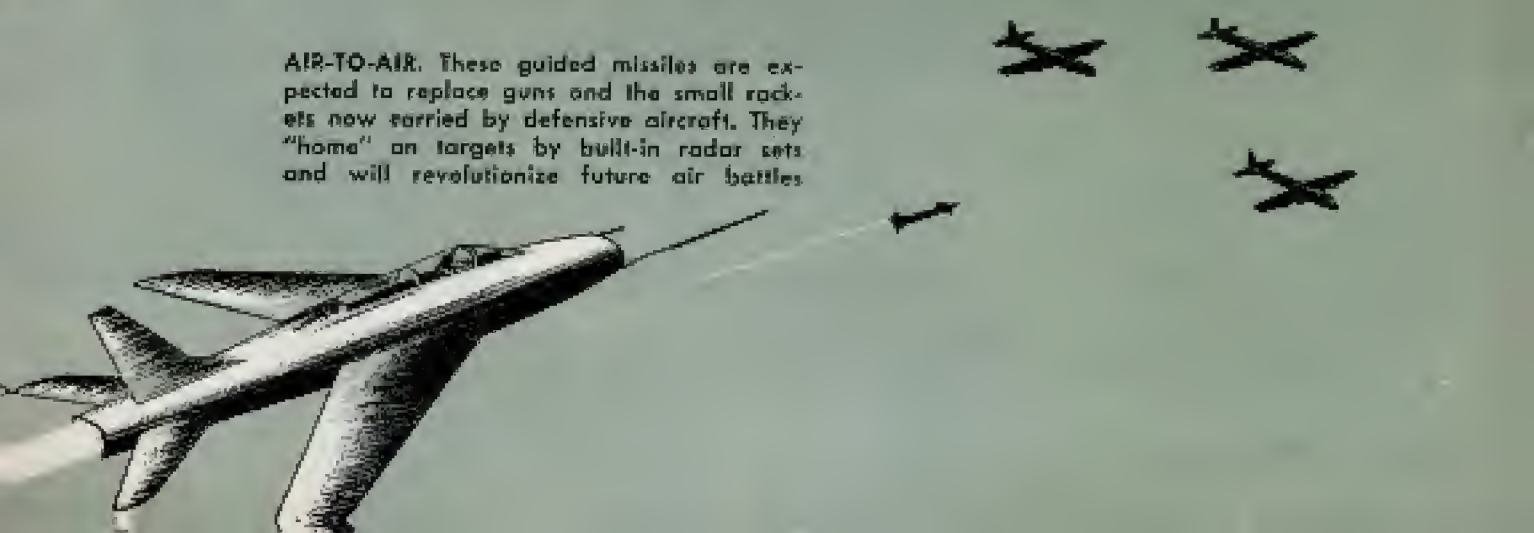

**AIR-TO-AIR.** These guided missiles are expected to replace guns and the small rockets now carried by defensive aircraft. They "home" on targets by built-in radar sets and will revolutionize future air battles.



Being fueled for a dawn launching, the Nike missile is handled by men (at top) wearing antacid gear

Surface-to-air missiles (SAM) eventually will make up our last line of defense against enemy bombers. They are anti-aircraft rockets fired from ground launchers and usually are propelled into the air by a booster unit that falls away when its power is exhausted. Then the rocket's own motor takes over and drives it at supersonic speed. These missiles "home" on bombers so rapidly that the pilots have no time to take evasive actions. The best known of the current SAM missiles is the

Richard F. Gompertz, chief of rocket branch at Edwards Air Force Base, with missile test stand model

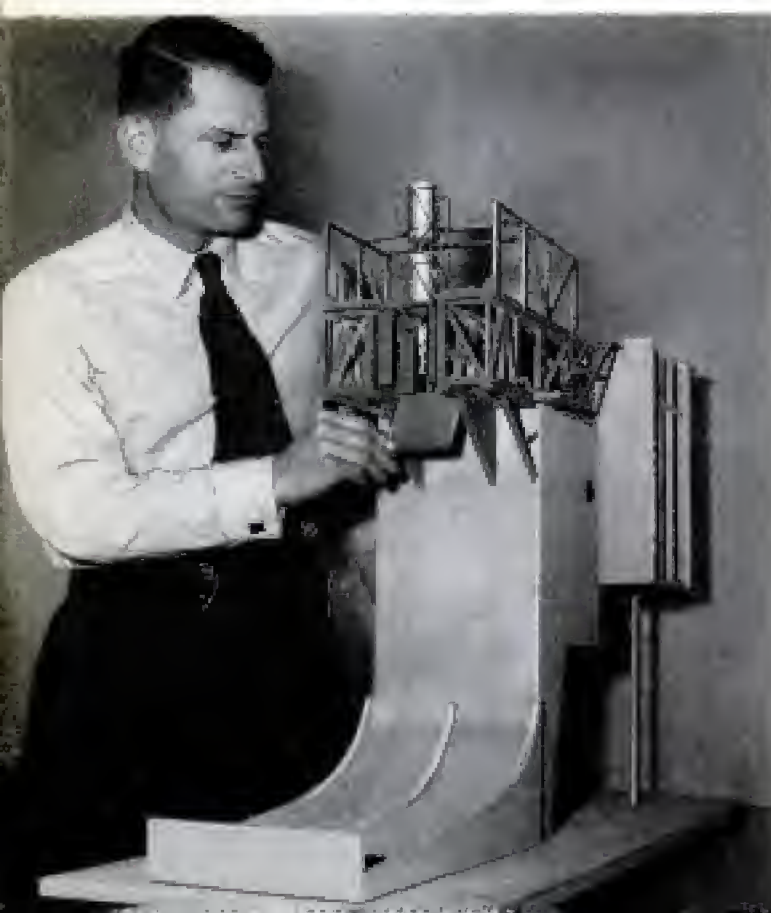

Nike, reputed to have a range in excess of 30 miles and the ability to knock out a bomber as high as 60,000 feet. Nike battalions, now being trained, will augment our radar-directed Skysweeper anti-aircraft guns around important areas.

Air-to-air missiles (AAM) soon may replace the small rockets, now carried by defensive aircraft, that must be aimed to intercept an aerial target. The new missiles do their own aiming, once they have left their mother aircraft, and they home on their targets by means of built-in radar systems.

Surface-to-surface missiles (SSM) include rockets fueled with solid or liquid propellants and that have ranges of from a few to a few hundred miles. Various types of pilotless aircraft can go farther. In a general way, the short-range missiles are comparable to artillery and the longer-range missiles will do the jobs now assigned to bombardment aircraft.

The Army's big Corporal is an example of an artillery type of rocket that has been developed to the stage where guided-missile battalions are now being trained to fire it.

One of the goals in this new kind of armament is to develop a true intercontinental guided missile. By definition such a missile should be able to carry a heavy warhead to a selected target as far as 4000 miles away. Undoubtedly, the only kind of warhead that a transoceanic missile would carry would be an atom bomb because of the tremendous cost involved in the project.

Missiles like this have existed on paper

Spillway shown in model at left is designed for the 500,000-pound thrust (below) of a missile in stand



for some time and by now some of their components have been tested. Northrop's Snark project is in this long-range category. Presumably the Snark is an uninhabited bomber having transonic or supersonic speed and equipped with a guidance system, possibly using automatic celestial navigation, for steering itself direct to its target.

There are many advantages in using a guided missile to do the job of a bomber. A missile doesn't carry a human crew nor does it have to make a return trip. All the weight and space now devoted to landing gear and to crew safety and crew comfort can be dispensed with. Training schools for crews are no longer needed. An uninhabited missile can be built cheaper than can a comparable aircraft, uses cheaper engines and can be launched from a small unimproved field.

On the other hand, a missile can never return to haul another load of explosives against an enemy. The biggest difficulty of all, however, is in devising a sensing system and brain to take the place of a human crew. This problem is being solved, slowly, though it is complicated by flight conditions including the extremely high temperatures that

(Continued to page 276)

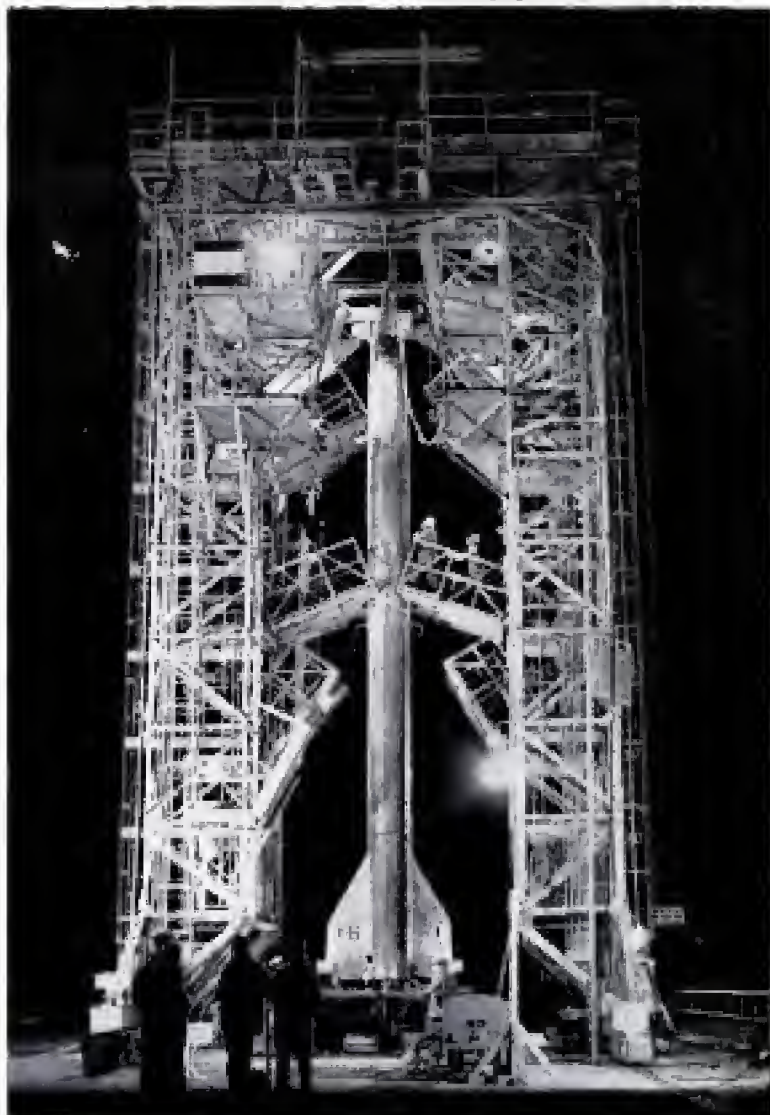

Elaborate scaffolding is required for launching of Viking high altitude research rocket at the White Sands Proving Ground, N. M.

Engineer, left, is ready to throw switch in control room at Edwards which will fire experimental rocket





Concrete block toe wall, which is helping an Illinois farmer control erosion, was first modeled in toy blocks

## Toy Blocks Teach Farm Construction

TOYS CAN DO a man's work on the farm. That conclusion was reached one Christmas day by Leland A. Ford of Lawrenceville, Ill., as he watched some children playing with small plastic blocks.

Ford, a U. S. Soil Conservation Service engineering aide, had been searching for a simple method of showing farmers how to build concrete masonry structures. Because technical details on a blueprint were difficult for some men to understand, ordinary plans didn't seem to be the answer. But the toy building blocks were.

Concrete and masonry structures are often needed on farms to control water runoff and erosion. Because some farmers aren't accustomed to building such structures, they need the assistance of Soil Conservation Service technicians.

Ford concluded that a model of a structure—a drop spillway, a toe wall or a box inlet—made from the blocks would give the farmer more help than any design or blueprint. The toy blocks are scale models of commercial concrete blocks. They are interlocking, make a rigid model and are available at most toy counters.

As a result of Ford's idea, the five farmer-directors of the Lawrence County Soil Conservation district purchased a set—400 full-size blocks and 50 half-blocks. The blocks worked out so well that directors of six other districts in Illinois have bought sets for their own technicians.

Use of the plastic-block models has cut in half the supervision time of technicians, who no longer need to remain on hand while the farmer begins construction. Ford, for example, makes a model of the structure and explains it to the farmer. In some cases he leaves the model for a few days while the farmer builds the structure. If it is a reinforced structure, he goes back only to show him how to place the steel.

The method caught the interest of farmers immediately and has been credited with a sharp increase in the number of erosion and water-control structures built in the Wabash Valley. In 1949, a total of 15 structures were completed by farmers. In 1951 the toys were put to use, and the following year the number jumped to 43, and in 1952 it rose to 84.



Engineering aid of Soil Conservation Service explains construction details to farmers. Below are models of typical structures



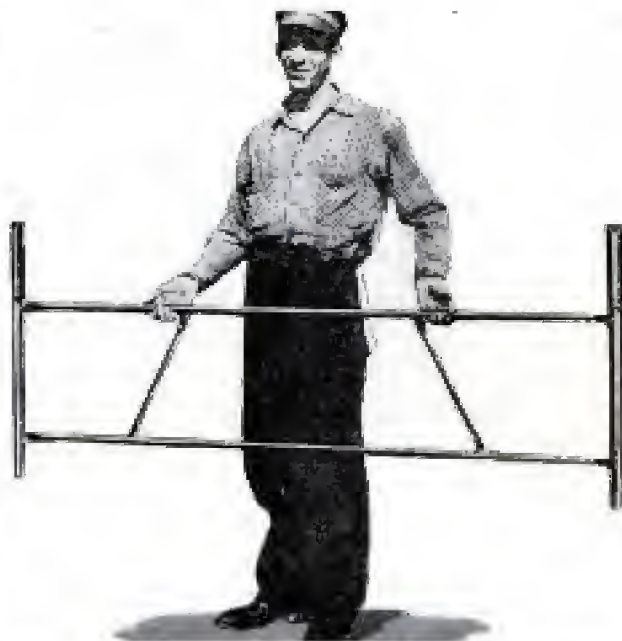
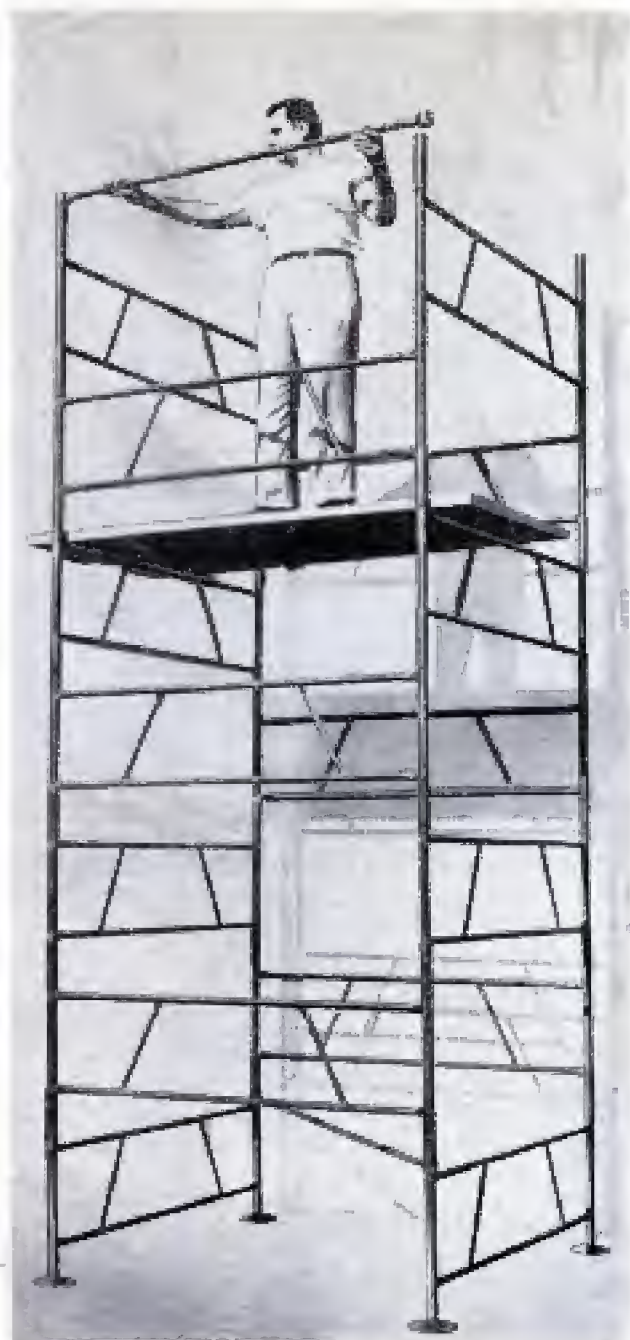

Above, 24-pound frame is basic unit of scaffolding. They slip into each other, below, to form tower, left



## Lightweight Scaffolding Goes Together Without Nuts or Bolts

Slipping together without fasteners of any kind, a lightweight tubular-steel scaffolding is said to cut erection time and labor in half. There is only one basic part to the system—a five-foot frame with two diagonal braces. These frames are stacked to form a hollow square. All are inter-

changeable. The lower ends of the vertical member slip snugly into the upper ends of the vertical members beneath them. Various other accessories are available, including cross braces, sidewalk frames, base plates, outriggers and putlogs. Each basic frame weighs only 24 pounds.

## Paint-Saving Chemical

Stored paint is kept fresh and smooth for months with a chemical which prevents wasteful skin formations. Colorless, it will not affect even delicate pastel shades, and does not change the drying rate of the paint. Enamels, varnishes, putty and calking compounds also retain their original qualities if the chemical, an antioxidant, is mixed with them.

## Fire Recovers Oil

Exhausted oil sands are set afire in a method to recover some of the 4,000,000,000 barrels of crude oil that cannot be removed by normal methods. Heat from the underground fire thins the oil so it can be pushed out of the well by air pressure. Laboratory tests have shown less than 15 percent of the oil is actually consumed by the fire. Field tests are now underway in Oklahoma.



Bell Aircraft Corp. photo

## Icebreaker Carries Helicopters for Survey and Rescue Work

Two Bell helicopters will operate from a specially built hangar deck on the new Canadian icebreaker, *d'Iberville*. They will

be used for aerial photography, surveying and rescue work, as well as to guide the ship through dangerous ice masses.

## Stilt-Legged Cyclist Draws Attention of Berliners to Circus



You can follow a West Berliner's example if you have a high motorcycle and short legs. Advertising a circus in the city, he wore stilts while riding his more than twice-size "bike."

## Massive Iron Ball At Center of Earth

If you could sink a shaft to the center of the earth, a core of solid iron would be found there, according to Dr. J. A. Jacobs of the University of Toronto. The solid core begins at a depth of 3100 miles and is surrounded by a thick layer of hot molten iron. It is believed that solidification occurred from the center outward and that the molten metal remained in that state due to the insulation above and below. As the earth cooled, the rocky layers on the outside solidified, not from the surface of the earth but at the bottom junction between the liquid mantle and the iron core. Earthquake waves had indicated previously that at least part of the earth's core is liquid because no transverse waves pass through the center of the earth.



Geese enter a cotton field. Each will likely find an individual row and work across field, nipping weeds

## "Field Hands" With Wings Keep Cotton Field Clean

Cotton and geese go together in New Mexico's Pecos Valley, where 30,000 feathered workers clean the Johnson grass from cotton rows. Shade is placed at one end of a field, and water at the other to keep the fowl moving back and forth along the rows. The geese love the grass but have no taste for cotton plants, work from dawn to dusk and do a cheaper and better job than manual labor. One to three geese per acre are required in fields mildly infested with Johnson grass; cultivation controls other weeds and grasses. In near-by Mesilla Valley, a thriving business has sprung up in dressing and quick-freezing the birds for market, but most Pecos Valley farmers hold their geese over from one season to the next. As one farmer explained it, "I'm not one who enjoys eating his hoe hands."

Prize "hoe hand" is exhibited by Artesia grower.→  
Weeders are lighter, more active than barnyard type



## Japanese Telephone Cord Reel Prevents Line From Snarling



Telephone cord is kept tangle-free by a spring-wound reel inside a telephone holder. The telephone is simply placed on the holder, and the cord to the handset wound around the reel. The cord unreels when the telephone is used and snaps back into its container upon the completion of a call. The device is manufactured in Japan.

Smaller and 110 pounds lighter than previous models, a Westinghouse direct-current arc welder owes its light weight chiefly to the use of aluminum instead of copper coils in the transactor unit, which controls voltage and current.



Boat is quickly detached from plane. Shaped like an airplane wing, it provides added lifting force in flight

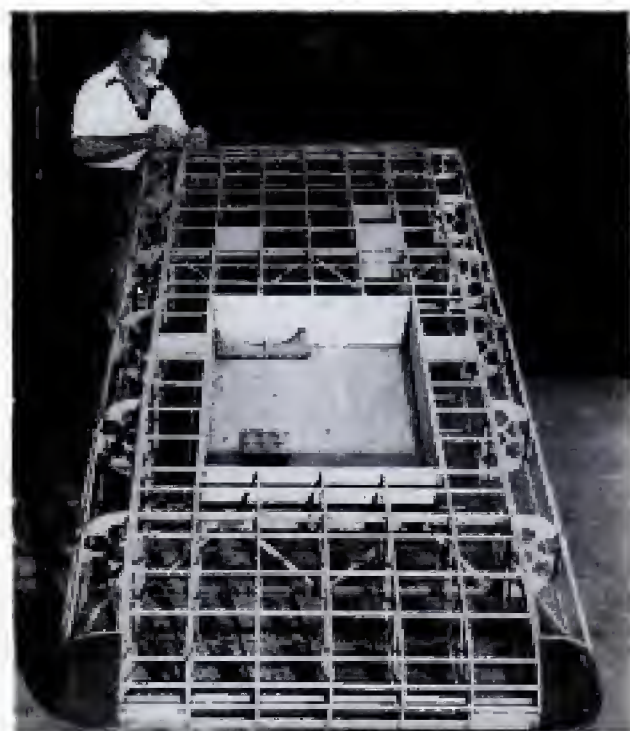

# FLY YOUR BOAT to the FISHING HOLE

Strong, lightweight structure was made from quarter-inch-square fir ribs and marine-mahogany plywood bracing sections. Below, cork blocks glued to each corner were rounded with tender. Note winglike shape

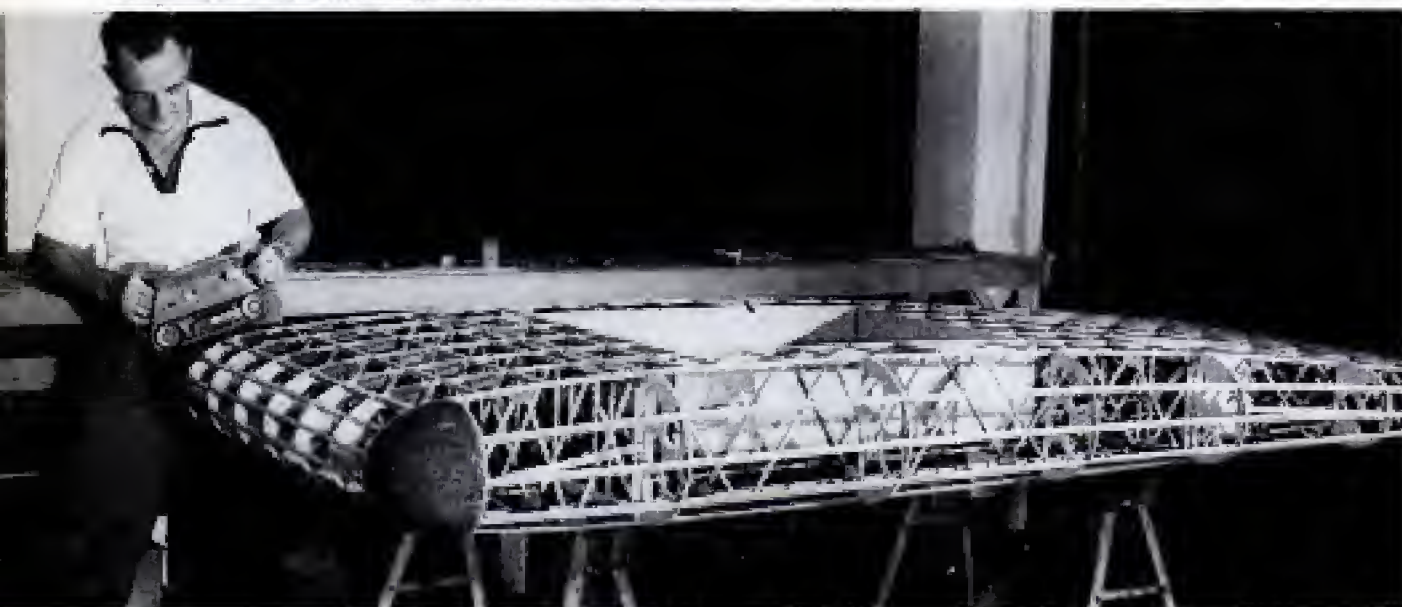





Highly maneuverable, boat weighs only 90 pounds complete with small motor and collapsible aluminum oars

**W**ITH A streamlined motorboat slung beneath his Lusecombe seaplane, Florida doctor Benjamin Bond swoops down on a favorite fishing spot minutes after leaving his office. Bond built the boat in the shape of an airplane wing. As a result, it offers minimum drag and provides added lifting force when the plane is in flight. Resting on the two main stringers that hold the pontoons, it is attached firmly fore and aft to the main float brace. The framework is built of thin lightweight fir strips, stapled and glued into place. Three-ply marine-mahogany plywood supporting sections brace the spars and ribs. The hull is plywood covered with glass-fiber sheeting and coated with plastic cement. A half-horsepower outboard motor fits into a small shaft open at top and bottom. Lightweight aluminum oars are also used. ★ ★ ★

Right, outboard motor, oars and oarlock fixtures are stowed in hatch for transit. With oars shipped, below, boat accommodates two passengers. Nine-pound motor fits into small open shaft, gives a speed of 5 m.p.h.





### Mobile Traffic Signal Is Powered by Battery

Traffic snarls are reduced to a minimum at a Texas drive-in theater by means of a portable traffic light developed by a San Antonio constable. The light unit is mounted on wheels and stands about 8½ feet high so it can be seen from a distance. The operator uses the light to direct outgoing cars onto the highway. A six-volt storage battery provides the power.

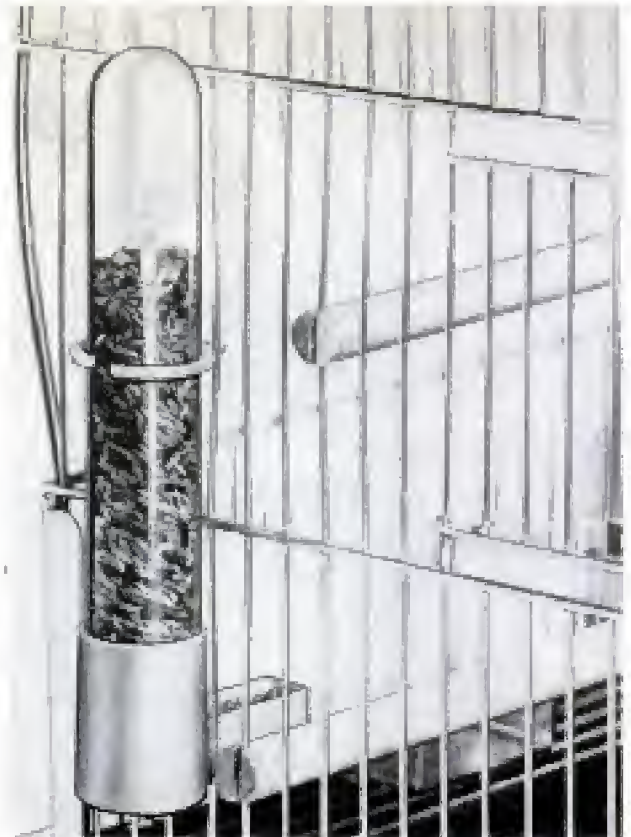

### Self-Feeding Bird Trough Holds Five-Day Supply

Now your canary or parakeet can feed himself for five days while you're out of town. Two small fountains, one filled with water, the other with seed, are fastened to the side of the cage with small clips. Each consists of a glass tube resting upside down in a plastic case and trough. As the bird empties the trough, the seed or water feeds down without waste.

### Suspension Camera Nearly 10 Yards Long Is Operating in Tokyo

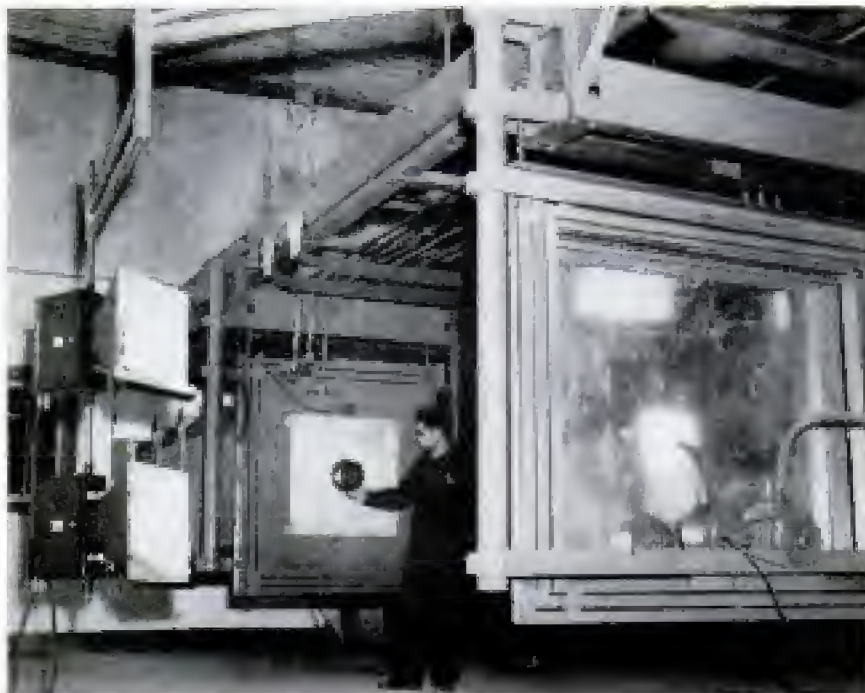

Believed to be one of the largest in the world, a suspension-type camera in a Tokyo government office is nearly 10 yards long. It has interchangeable lenses of 1800, 900 and 170 mm. The camera can be automatically operated from within a darkroom with an exposure meter, a flash eye and an automatic-shutter mechanism.

ⓄDespite their fragile appearance, the thin wings of one modern jet fighter could easily support two fully loaded four-engine airliners, almost 150 tons of dead weight.



Left, torch has little effect on fireproof roofing material. Right, covering roof with wood-fiber planks

## Fireproof Roofing of Wood Fibers Also Provides Insulation

Buildings covered with fireproof wood-fiber planks or tiles cost less to heat in the winter and to cool in the summer. The new roofing material, made of wood fibers bound with cement under heat and pressure, also has high insulating value. A plank, 2 inches thick, is equal to 1½ inches of cork in insulating value. The roof-deck material weighs only 2 pounds to the square foot for each inch of thickness. The cement

joining the fibers makes the material fire-proof. Installation of the planks or tiles eliminates the need for acoustical material. The dimensionally stable material can be sawed, kerfed, routed, drilled or mortised and nailed. A saturated-roofing felt applied to one side in the factory cuts hours of construction time. The other side has an interesting swirling effect design in off-white and does not require painting.

## Musical Slide Rule Aids Composition and Transposition

Anyone can write major and minor scales, chords and transpose music from one key to another with a new musical slide rule. A fixed pattern of Xs is moved along a rule representing the black and white keys of a piano. At any position, the note above the first X is the key signature. The notes above the other Xs are the notes in that scale. A similar method is used for obtaining major and minor chords. This time, a rule representing a piano keyboard is moved into position below rows of Xs representing the spacing of different chords. Directly below the Xs for a given chord are the notes you should play in the chosen key. The fixed keyboard rule and the movable keyboard rule are used in transposing music from one key to another. The key note of the music as written is moved into position above the new key note. Under each note as

written in the selection, found on the movable rule, will be the corresponding note in the new key. Especially useful to arrangers of orchestra music are two sliding scales which give directly the corresponding keys for all instruments in the orchestra when the key for any one instrument is given. A book of exercises is included.

SCALE I CHORDS IN ANY KEY

SCALE I	C	D	E	F	G	A	B	C
SCALE II	C	D	E	F	G	A	B	C
SCALE III	C	D	E	F	G	A	B	C
SCALE IV	C	D	E	F	G	A	B	C

MAJOR SCALE MINOR SCALE HARMONIC JORD

SCALE V SCALE VI

TRANSPOSING INSTRUMENT

SCALE V SCALE VI



David Pickoff photo

Wally Cox, the Mr. Peepers of television, hones a woodcarving tool at his workbench where he spends hours

# Mr. Peepers Does His Homework

Wally uses razor-sharp tool to carve mahogany bust

By Fred Marshall



**YOU CAN MAKE** a fine lamp out of a sculptor's mallet. It's a truncated cone—perfect for lamps. Just bore a hole up the middle, pull a wire through, fasten a socket to the end and there's your lamp. The tapered cylinder makes the base, the handle forms a stem on which you hang the shade. Sculptor's mallets usually are made of lignum vitae—a very heavy wood that comes from a tropical hardwood tree."

My education in the matter of sculptors mallets and what you can do with them, besides pound clay, came from a slight, friendly young man with thick-rimmed glasses and a somewhat studious manner. He sat at a cluttered workbench in a shop off the living room of his three-room New York apartment. As he talked he was busy reaming a hole in a piece of bamboo from which he assured me a shepherd's pipe would emerge in a few minutes. In the

background, a blowtorch gas jet hissed blue flame, warming up for a little silver-smithing job he had in mind.

Wally Cox, known to Sunday-night TV fans on the NBC channel as "Mr. Robinson Peepers," timid general-science teacher at Jefferson Junior High, is more famous for his two-suit wardrobe, baggy pants and for "being just like Mr. Peepers" (which isn't exactly true) than for being a remarkably original and painstaking craftsman (which is an understatement).

His shop is a clutter of delicate handmade silver and gold chessmen; wood carvings of hands, figures and boats; bamboo pipes and odd appliances. Despite an income that will be greater than \$100,000 this year, he's building a house with his own hands (and those of any friends he can snag) on a two-acre tract in Rockland County. His motorcycle, which he prefers to automobiles, was hopped up by Cox to increase its speed and efficiency.

Anyone, Wally feels, can do the same, given the desire and ability to experiment. To help spur those interested in producing shepherd's pipes, custom-built shoes, silver trinkets and "souped up" motorcycles, he agreed to give *Popular Mechanics* some of the formulas and techniques employed in his projects.

Nearly everything Wally Cox turns out is unique. There's the simple shepherd's pipe for instance. It's a plain piece of bamboo, about an inch in diameter and 14 inches long, drilled straight through the natural joints. Six or seven "stop" holes are drilled up the side (depending on desired range), positioned so the fingers fit over them naturally. "The first one you make will be a total failure," he predicts calmly. "But don't give up."

Each hole is drilled with a  $\frac{1}{8}$ -inch bit, then reamed out until a true tone is reached. Most important is the first hole at the bottom. "You drill the hole, put the pipe in against half



David Tschoff photos

Wally explains to Pat Benoit (Nancy Remington of the Peepers show) how he rebuilt motorcycle engine. Below, actor demonstrates its improved performance





First step in making a silver ring is to snip a 1/4-inch band of silver from sheet. Cox worked as silversmith before TV



Second step in making ring is shaping silver band in circle and soldering at the joint with silver solder as shown here

Final shaping of ring is accomplished by slipping it over a mandrel and hammering into a perfect circle before polishing



your mouth, covering most of the top of the pipe. Then blow gently across the opening until you get a sound," says Wally. "It won't be right at first, so you ream the stop hole a little at a time, testing until it sounds just right. The rest of the stops are drilled the same way, until you can go right up the scale in perfect tune. That's all there is to it. You can make one in 30 minutes."

The finished pipe looks mighty unimpressive. But, lying on the lounge in his living room, Wally can pull hollow, haunting melodies from it with all the soulful nostalgia of a burnoused Arab tending flocks along the River Jordan. "Takes some practice," he admits. "I've seen expert woodwind musicians who couldn't blow anything out of it but gusts of air. You've got to kind of tilt it against half your mouth and breathe across it."

Not everyone would think of making a shepherd's pipe. But for Wally it was a natural. He happened to read about one in an old book and decided that if a shepherd could make one and play it, he could. So he did. Its utter simplicity and the eerie music it produces, make it a useful and satisfactory project, he feels.

Usefulness, comfort and expediency are the keynotes of Wally Cox's approach to everything in life. He has no time for what he considers the hidebound nonsense and fripperies demanded by a spoiled, twentieth-century American society. He's not sure, for instance, that inside plumbing will be necessary for his Rockland County house. There are no ashtrays in his apartment. He doesn't smoke, but even if he did there probably wouldn't be any. "Try a frying pan," he told one guest who'd been desperately balancing a long ash on the end of a cigarette. "There's one in the stove."

One writer, waiting to interview Wally in his dressing room when the 28-year-old actor was playing in *Three Men On a Horse* at the Westport, Conn., County Playhouse last summer, got the start of his life when Cox came in through the window instead of a door the fellow had been watching. Wally smiled, shook the writer's limp hand, and explained: "Coming in this way saves me exactly one minute and fifteen seconds walking



Wally tests shepherd's pipe he made for accuracy of tone. It's made of a stick of bamboo open at ends

time from the parking lot. I timed it."

This type of practical unconventionality is strictly Wally Cox. It goes into the character of Mr. Peepers in every show, and it goes into the things Wally invents and builds. It explains how he happened to make a pair of incredible shoes.

"Rehearsing eight hours a day five days a week calls for a lot of standing around, which is hard on the feet," he points out. "Ordinary shoes don't give support all around. So, I decided to make a pair that would. They look absolutely terrible, but they're the most comfortable shoes in the world. Easy to make, too."

Wally Cox shoes are simply built right over a pair of socks on your own feet. "Put on two pairs of socks," he warns, "otherwise, there won't be space to wear socks under them when they're finished."

The outer pair of socks is completely coated with molding latex, built up layer after layer until proper thickness is attained for uppers and sole as well. Bits of sponge rubber can be pressed into the sole to help build up its thickness. "To get a perfect fit," explains Wally, "you should stand on a foam rubber mat while the latex hardens and sets. That way the sole will be pressed upward and molded to the contours of your foot."

Standing on a foam-rubber mat for three hours while the latex "sets" may be somewhat gruelling, he admits, but the end result will be satisfying if you can take it. "I found it was possible to shift my weight occasionally," he says. "And, of course, you can read a book or something. That's what I did."



David Pickoff photo

Stops in Shepherd's pipe are reamed until correct tone is achieved. Holes are made with 1/8-inch bit

When the latex is firm, the outer socks (now actually rubber shoes) are slipped off the feet carefully. "Uppers" are covered with kid, which sticks beautifully to the still tacky latex, Wally reveals. Then just run a slit down the instep, punch some holes down each side of it, and string your shoes with laces. "Since the latex impregnates the sock, and molds into every hollow of your foot," says Wally, "the shoes really fit and support your feet. They can be used like sneakers, but they're much better."

Wally Cox's off-trail approach to things like shoes and people bears a startling resemblance to the whimsies of the character he portrays on the TV screen Sunday nights, and is probably why some people have tabbed him as an actor who just "acts himself." Actually, the resemblance between Cox and Peepers shears off somewhere along here. Peepers might stumble into a fortune without knowing how it happened, and would be utterly dazed and confused about what to do with it. Wally Cox who will make \$1,000,000 in the next few years, knows exactly how it happened, and he is fully aware that he's worth every penny of it. "People who cry about not getting any place make me sick," he says. He beat on nightclub doors and pounded pavements, scrounging bit parts in small shows for years before he finally hit big time in TV. While he hasn't much use for the material gewgaws like big cars, dazzling homes and important clubs that most people find essential (he prefers bird-watching, nature study and tinkering), he has sound channels for his money. He just



Wally puts finishing touches on silver badge with raised gold letters which he made for the TV producer of Mr. Peepers

Left, Cox starts work on his biggest project—clearing the ground for house he is building in Rockland County, N. Y.

bought a huge successful farm that will be operated for him on a business basis, for instance. He has a canny, un-Peeperish awareness of the value of a large following of loyal fans, and an un-Peeperish determination that neither they nor anyone else shall change his way of life.

Biggest clue to the un-Peeperish drives that propel Mr. Cox, however, is the souped-up motorcycle that he prefers above all other means of transportation. On it, he roars (with considerable abandon, according to friends who've ridden the buddy seat) between his Rockland County foundation hole and the New York NBC studios. Hopping up the motor was not necessarily just to squeeze more speed out of the thing, he claims, but simply because the engine annoyed him by being less efficient than it might be.

"You can do the same thing to any factory-made engine," he points out. "Makes a big improvement, and anyone can do it. My motorcycle engine was designed so the gasoline comes through the intake ports at 200 feet per second. Unless these ports are glass-smooth—which they never are—there's a lot of skin friction. So all you do is remove the head, take the burrs off the intake ports with a fine file, then polish the walls down with a grinding wheel, and finish them with a rubber wheel. There's all the difference in the world."

This done, Wally installed dual carburetors, put in high-compression pistons and

he was "off to the races." "Boosted performance 20 percent," he claims.

By all odds, the most painstaking and craftsmanlike work performed by Wally in his spare time is the metalwork he turns out. Long before 1948 when he took to yodeling, whistling Bach fugues in a plaintive manner and rendering ludicrous monologues to entertain people, Wally Cox earned a \$50-per-week living by making silver jewelry that he sold to Fifth Avenue stores. Through several years of this work, he achieved a remarkable degree of perfection in it and he still indulges the craft as a pastime. Right now, he's making a silver-and-gold badge for Fred Coe, producer of Mr. Peepers. Across its hand-hammered front are raised gold letters "Producer." Gold moons and stars are soldered to the shield. Tiny signatures of everyone in the cast have been scribed on a thin silver sheet, and painstakingly cut through the precious metal with a jeweler's scroll-saw. This will be soldered to the back of the shield after it has been oxidized to make it black so the signatures will stand out.

The more intricate the work, the more intensely Wally goes at it. Hunched over his workbench, he twists tiny hairs of silver wire into perfect chain links so small you can barely put a pin through one. His set of silver-and-gold chessmen, made of square silver wire and sheet silver, have

(Continued to page 272)



## 'Scanar' Finds Submerged Objects With Bouncing Beam of Sound

FISHERMEN and marine pilots can "look around" underwater through a new instrument using sound waves in the same manner that radar uses radio waves. The instrument, projecting beneath the ship's hull, sends out sound waves in a series of "pings" that bounce back from anything beneath—or even above—the water. The echoes are "painted" on a cathode tube to give a radar-type image. At the same time the sound of the echoes comes in over a tiny loudspeaker. An experienced man, by watching the shape and character of the light patterns and listening to the echoes, can identify objects above and beneath the surface. He can locate objects on the surface around the ship, examine the sea bottom and even identify types of fish. Herring, for example, make a football-shaped spot of light while salmon produce a very sharp and brilliant spot. In the case of fish, their air sacs, bounce back the sound waves in identifiable patterns. The new system, based on sonar, is valuable because it operates like a powerful searchlight to scan both above and below the water. Radar operates only above the surface and conventional sonar beneath the surface. The new instrument has a range of 1600 feet. "Sea Scanar," developed by Minneapolis-Honeywell, is designed for use by fishing fleets to locate schools of fish, and as an aid to navigation.

Drawing shows how underwater instrument sends out sound waves which "bounce back" from fish



Top, instrument projecting beneath hull sends beam of sound waves which sweeps water. Above, objects show up as light pips on radar-like Scanar screen

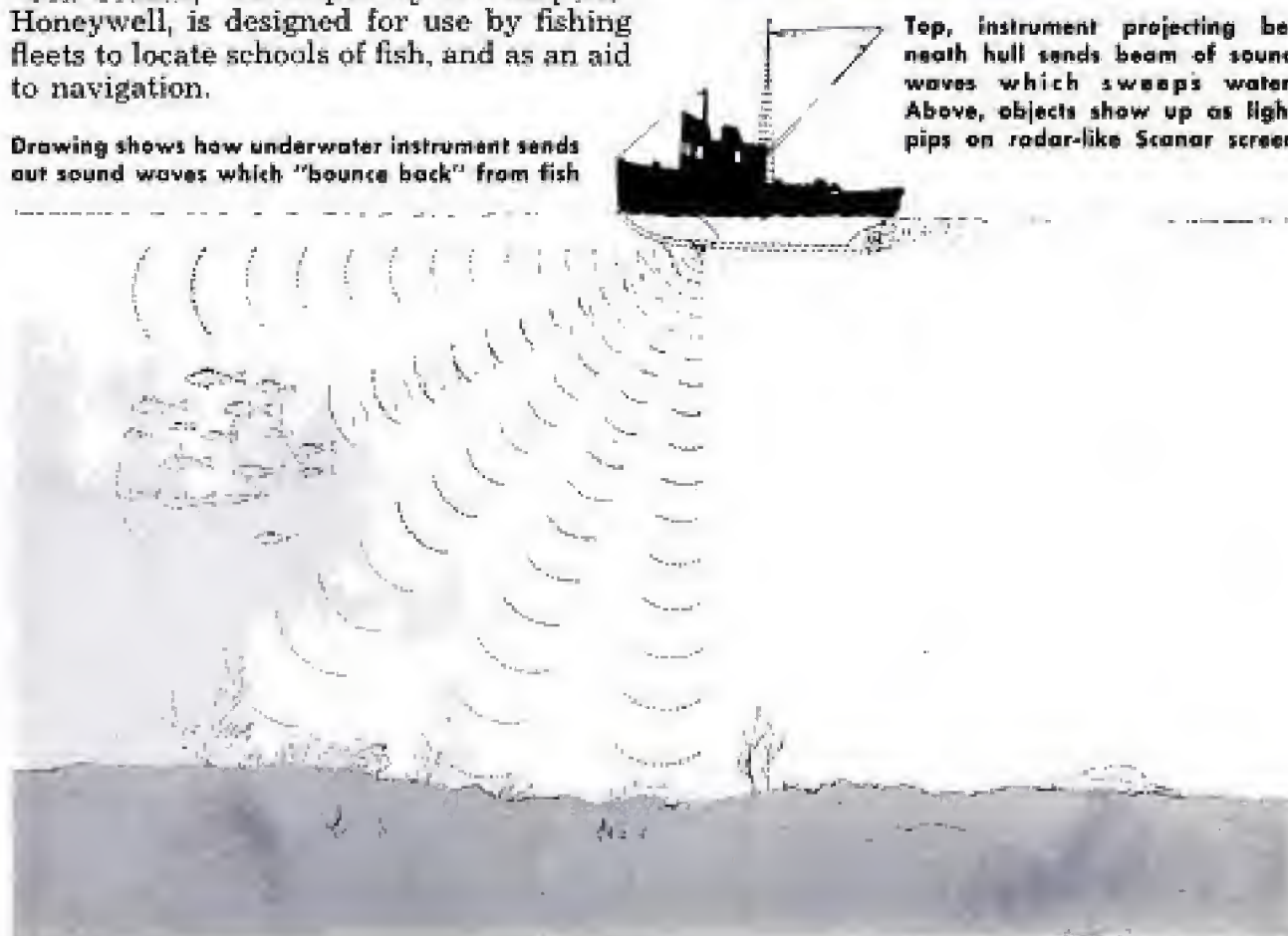

# WHAT'S NEW FOR Your Home



**1. FAT FILTER** purifies and freshens cooking grease for repeated use. The filter consists of an aluminum unit that fits over shortening containers, and a chemically treated filter. The chemical counteracts fatty acids which cause fats to turn rancid. The filter is finely woven to trap all foreign particles

**2. GEM SETTER** that works like a stapler permits anyone to set rhinestones or pearls in fabric. Easy and economical to use, the device works on the same principle as professional machines. A dozen complete sets of rhinestones and settings are included, and refills of rhinestones or pearls are also available

**3. CHERRY PITTER** removes stone from cherry at the push of a button. No hands touch the fruit, which is fed from a hopper. Sharp blades at the end of the pestle cut open the fruit and a rubber device lifts out the pit. Stones and juice fall into a glass container and the pitted cherries drop onto a plate



**4. VAPOR STRIP** that is fastened to an electric light bulb discharges colorless insecticide when bulb heats up, keeps area free of insects. A single strip lasts for several days. Adhesive on the back of the paper strip results in quick application. The vapor is stainless and will not harm clothing, furniture, carpets or woodwork



**5. POTATO PEELER** strips skin from bumpy tubers, apples, pears and hard fruit of any size. You just spear the potato on the sharp prong, turn the handle and the peeler does the rest. A strong clamp lock holds the machine firmly to the table top. Fine or coarse parings can be secured by an adjustment of the sharp cutting knife



**6. ROUND THERMOSTAT** can be painted or wallpapered to blend with background. Dustproof plastic cover is quickly removed. One pointer on the easy-to-read dials indicates room temperature, the other regulates the thermostat. Attractive appearance of the compact instrument allows it to be mounted at most effective position in room



**7. SPRAYER** which fits on the end of a garden hose dissolves a cartridge of soap or insecticide to clean the family auto or rid the garden of insect pests. Various kinds of insecticide cartridges are provided to meet particular spraying needs. Range of the sprayer is from 3 to 25 feet. A shut-off valve is mounted on the hose end





Railroad leaps across chasms, through mountains, along cliffs

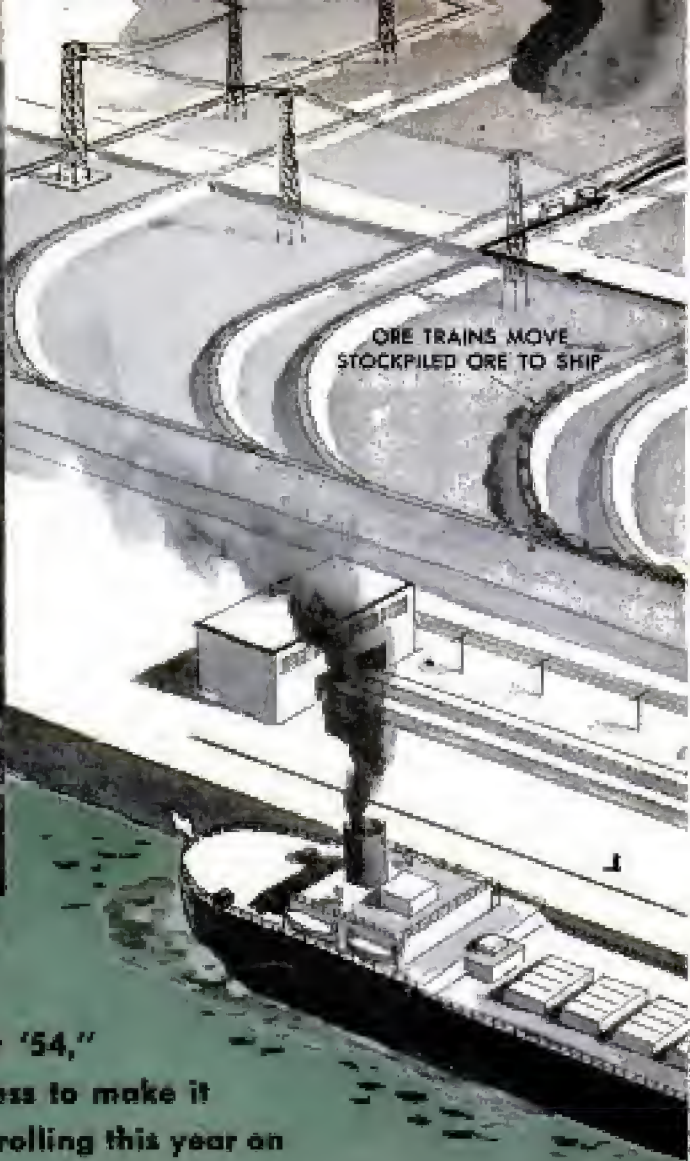

For six years the cry has been "Ore by '54," and 6000 men have battled the wilderness to make it come true. Ungava's fabulous ore will be rolling this year on

## The IRON ROAD to LABRADOR

By Richard F. Dempewolff

**G**IANT "CATS" are roaming the forests and lake-strewn wilds of Labrador. They're gouging the muskeg, toppling the stunted spruce trees and pounding the thick moss carpet to a pulp.

They have carved a 360-mile gash from the boom town of Seven Islands on the St. Lawrence River to a bleak campsite at Knob Lake, between Hudson's Bay and the coast. The bulldozers are grading a right of way for the biggest railroad-building project this continent has seen in nearly half a century.

Since 1950, an army of 6000 men has battered its way northward through a land so inhospitable that, until they came, only a handful of Indians prowled the shores of its myriad lakes to hunt bear and caribou, or set traplines for mink, marten and muskrat. But by last July the steel had reached Mile 140. Farther up the line, graders were pushing past Mile 185.

Behind them lay the rugged mountains through which they drilled and blasted their way via two tunnels—one 2200 feet long, the other 760 feet. At Mile 12 they'd carved grading from the sheer granite sides of towering cliffs, sent steel girders leaping 708 feet across a deep gorge over the Moisie rapids where seals bask and preen their whiskers.

Ahead lay the goal—a bleak tableland of jagged rock swept by Arctic winds whistling down from Ungava Bay. Cinnamon-red hills surround a large campsite of log buildings on a dirt street called Burnt Creek. Jeeps whine and pitch over roads that disappear in the bush. In this terrain, a Jeep is a wreck at 10,000 miles. Mobile churn and diamond drills—some of them riding weird, marsh buggies to support them on the soft muskeg—tower against the sky, their bits probing for the rich iron ore that is the reason for all this activity.

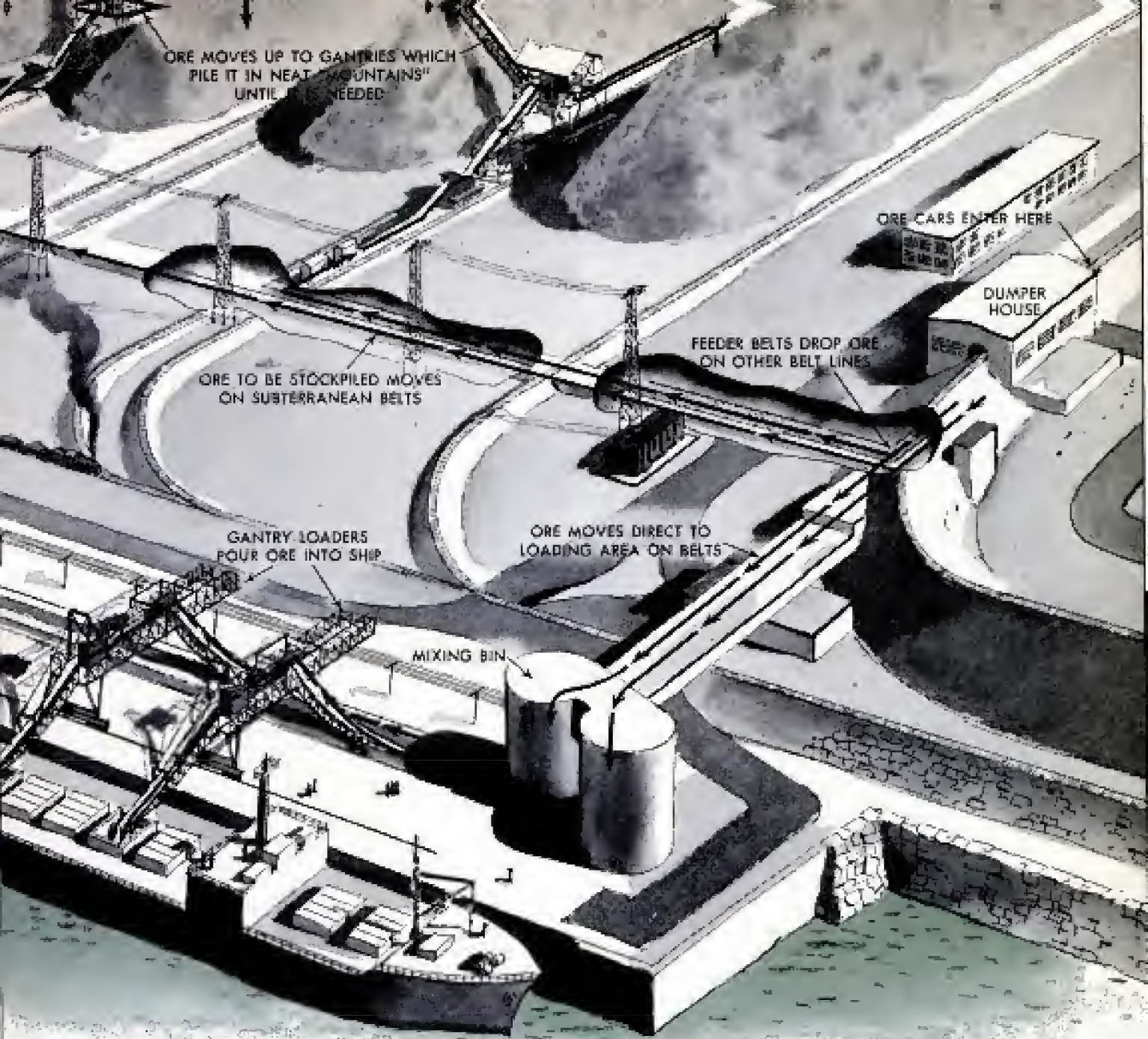

Artist's drawing shows ore terminal at Seven Islands. Ore moves on subterranean belts to ship or stock piles. Right, map shows location of ore zone and railroad

Since 1890, geologists have known of iron in Labrador. By 1929 a few hardy expeditions had probed the vast region and found deposits of fairly good ore. Then in 1936 an Indian walked into the camp of a geologist named Joseph Retty with a piece of jagged rock he'd picked up in the far north. It was all over the top of the ground, he reported. Retty assayed the sample and found it was better than 65 percent pure iron. That was the beginning of painstaking exploration by Retty and Dr. Albert Moss. In Jeeps, swamp buggies and on foot they prowled an ancient precambrian trough, folded by prehistoric upheavals, eroded by glaciers and arctic water that had laid bare long outcrops of incredibly rich ore. "Like raisins in a gigantic fruit-cake," is the way Retty described it.

Shrewd mining men studied the reports

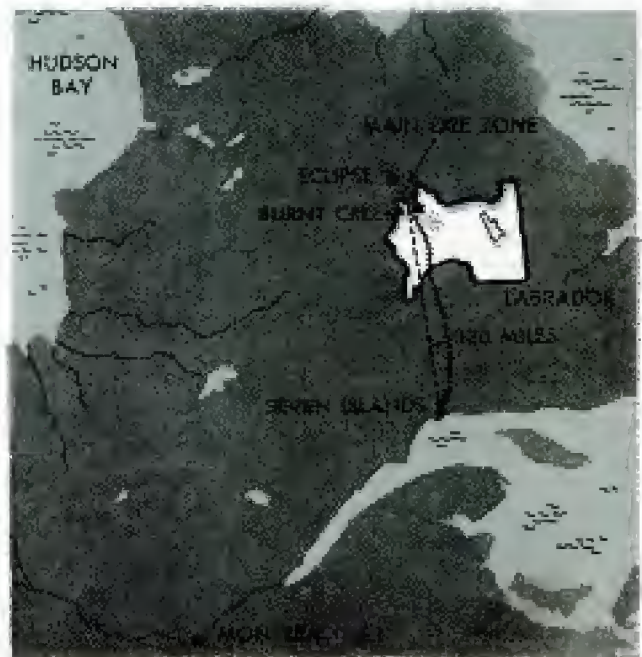

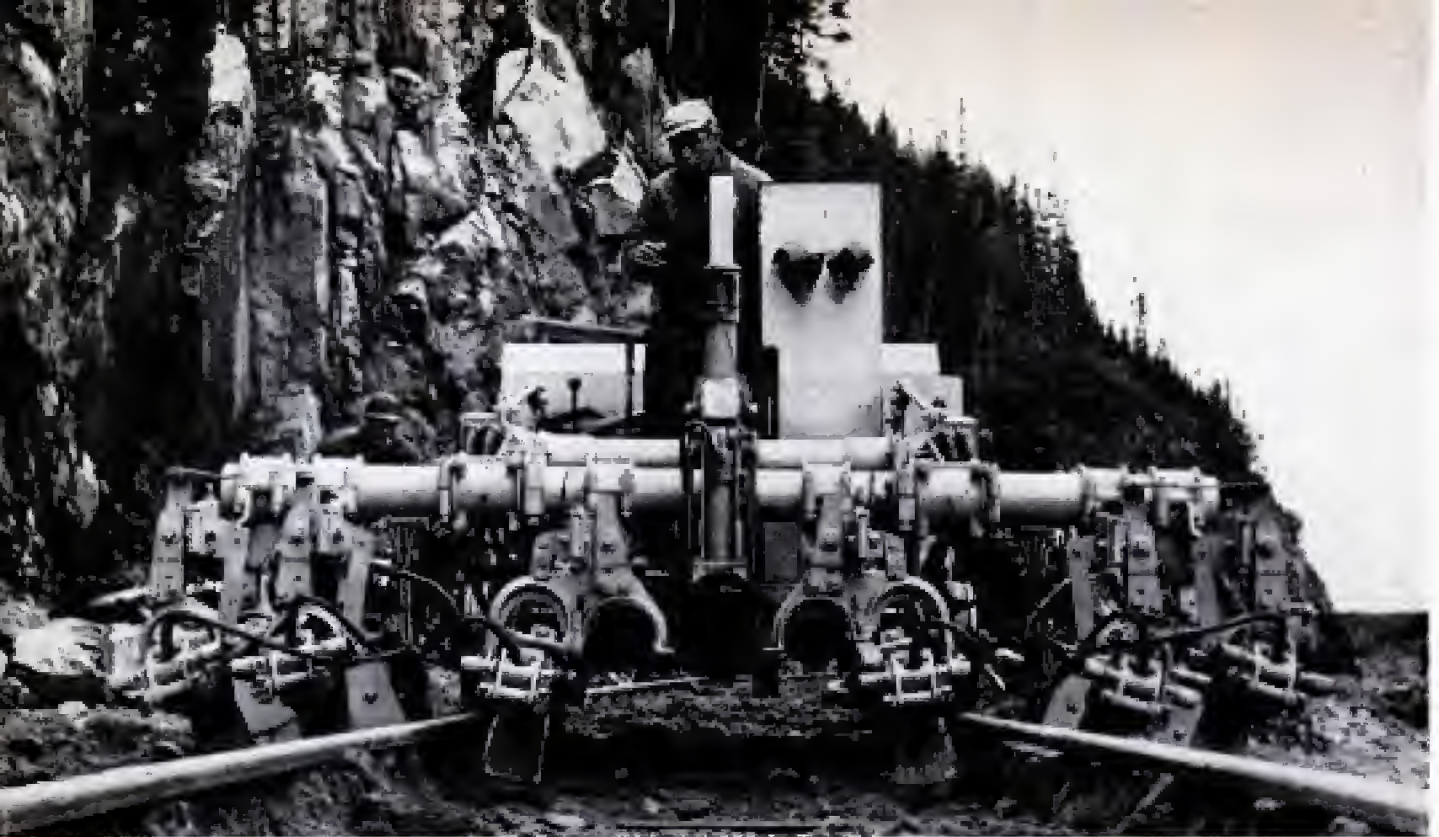

John Rodriguez photos

Steel teeth of this big ballaster pound gravel between the rail ties to give the track a firm footing

and put their heads together. The Mesabi Range had been worn thin. The United States gulps 100,000,000 tons of ore each year. In event of war, this new deposit would be more strategically located than the new iron discoveries in Venezuela. Its rich ore could be railroaded 360 miles south from Ungava to the St. Lawrence, and shipped by river and canals to Great Lakes smelters or up river to Canadian ports.

To reap the iron harvest, Canada's Hol-

inger Consolidated Gold Mines joined with the M. A. Hanna Company of Cleveland and five United States steel companies, forming the Iron Ore Company of Canada. So far, IOC's drill bits at Ungava have proved up 500,000,000 tons of ore running 65 to 67 percent pure. Cautious experts now estimate they'll find a fantastic jackpot of 2,000,000,000 tons before the roving drill rigs have wheeled their fat, five-foot tires across the last, long stretch of desolate

Sections of track are prefabricated, rolled to the end of the line on railroad trucks, dropped into position



muskeg and probed the last "raisin in the fruitcake."

And, if all goes well, the first of that ore will twist its way down on a 13-hour run from Knob Lake to Seven Islands this June.

The sturdy, 54,000-pound, 30-foot carriers are one solid piece with no chutes or doors to jam in icy Labrador winters. Each will tote 95 tons of ore. In 1954, 2000 cars, hauled by 53 diesel units will carry 10,000,000 tons of ore to the push-button terminal that is nearing completion at Seven Islands.

Glenn Hornke, who worries about these facilities, explains the tricks with considerable enthusiasm. "Trains will roll into the yard and move over the hump at two to four miles per hour," he says. "An electronic scale will weigh each car in. Electronic brains will do the work. Cards will slip into the scales and get punched. All grading, in five-car samples, will be made at the mines and recorded on the card for each car before it comes in."

Rolling on, cars enter a concrete dumper house, two at a time. Here a massive rotating dumper will grab them, flip them upside down in tandem, rotate them right side up again and send them rolling out the other end toward the yards. "She'll handle 45 dumps, or 90 cars, per hour," says Hornke.

What happens to the ore couldn't be duplicated in a Coney Island fun house. From the overturned car, it drops deep into the 90-foot hollows of the dumper house through a pair of concrete funnels the size of a three-story home. "The dumper house goes down 19 feet below the mean water table," Hornke points out, "so we had to build her like a boat hull."

From the chutes, ore falls on a short, endless belt feeding out to a maze of caverns and tunnels. It may drop off one end of the



Fahn Rodriguez photos

Work was delayed when dynamite blast collapsed roof of tunnel. Mountain washed down through hole

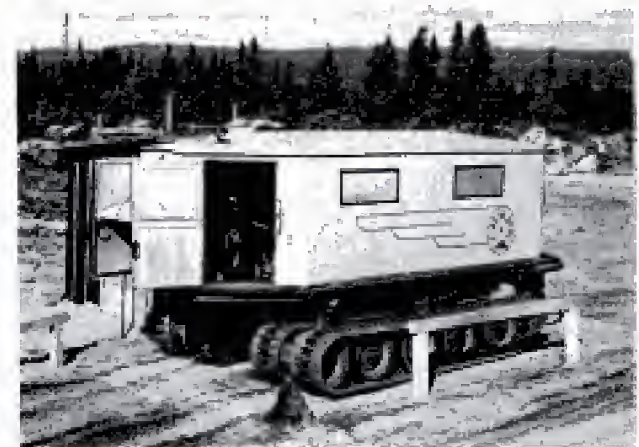

Engineers invented the ingenious, four-tracked "muskebile," but even it bogged down in mushy muskeg

Thundering spring flood washed out a concrete bridge here, leaving the rails high, dry and unsupported





John Rodriguez photos

Experimental "steel sled" is swung into position. It will be slipped under the jacked-up tracks

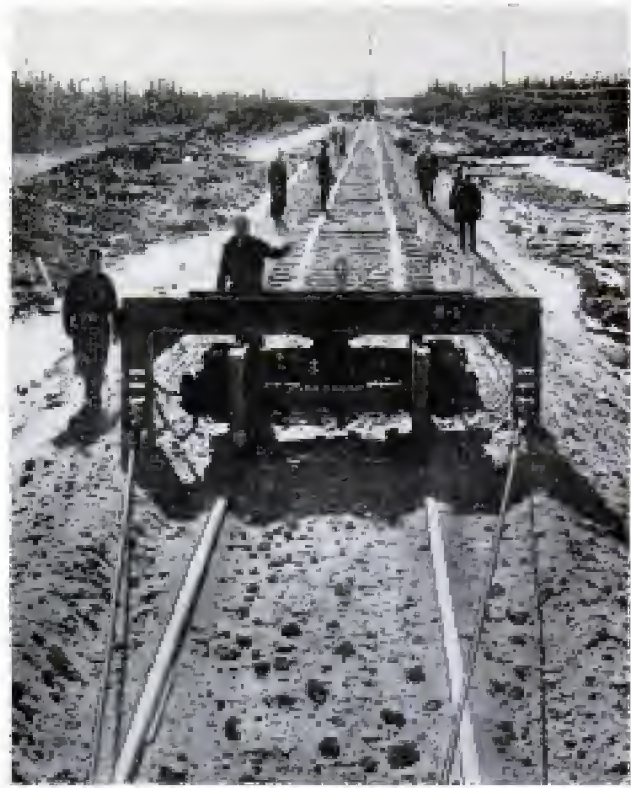

"Sled" then is pulled along for miles, lifting the rails and ties and allowing ballast to drop through

belt and fall onto other belts that will carry it thousands of feet underground, then up to stock piles where huge gantries will pile it in neat "mountains" until it's needed. But supposing a ship is already waiting for it? When the endless belt is reversed, the ore drops to a second series of belts on the other side that carries it up through long subterranean tunnels to mixing bins, where various grades of ore are blended to any degree of purity needed. The blended ore

feeds from the bottom of the mixers onto belts that rumble out along the docks to gantry loaders. The gantries, riding back and forth on wide-spaced tracks, pick up the ore and feed it into the hold of the ship at a total rate of 8000 tons per hour.

Building a fancy modern port that one day may funnel 40,000,000 tons of ore a year from the wilderness was no easy job. When C. E. McManus, rugged project manager for the job, and Jack Little, field boss

All over the Labrador wilderness diamond drills on half-tracks bore through muskeg to locate new ore bodies  
Canadian Film Board photo





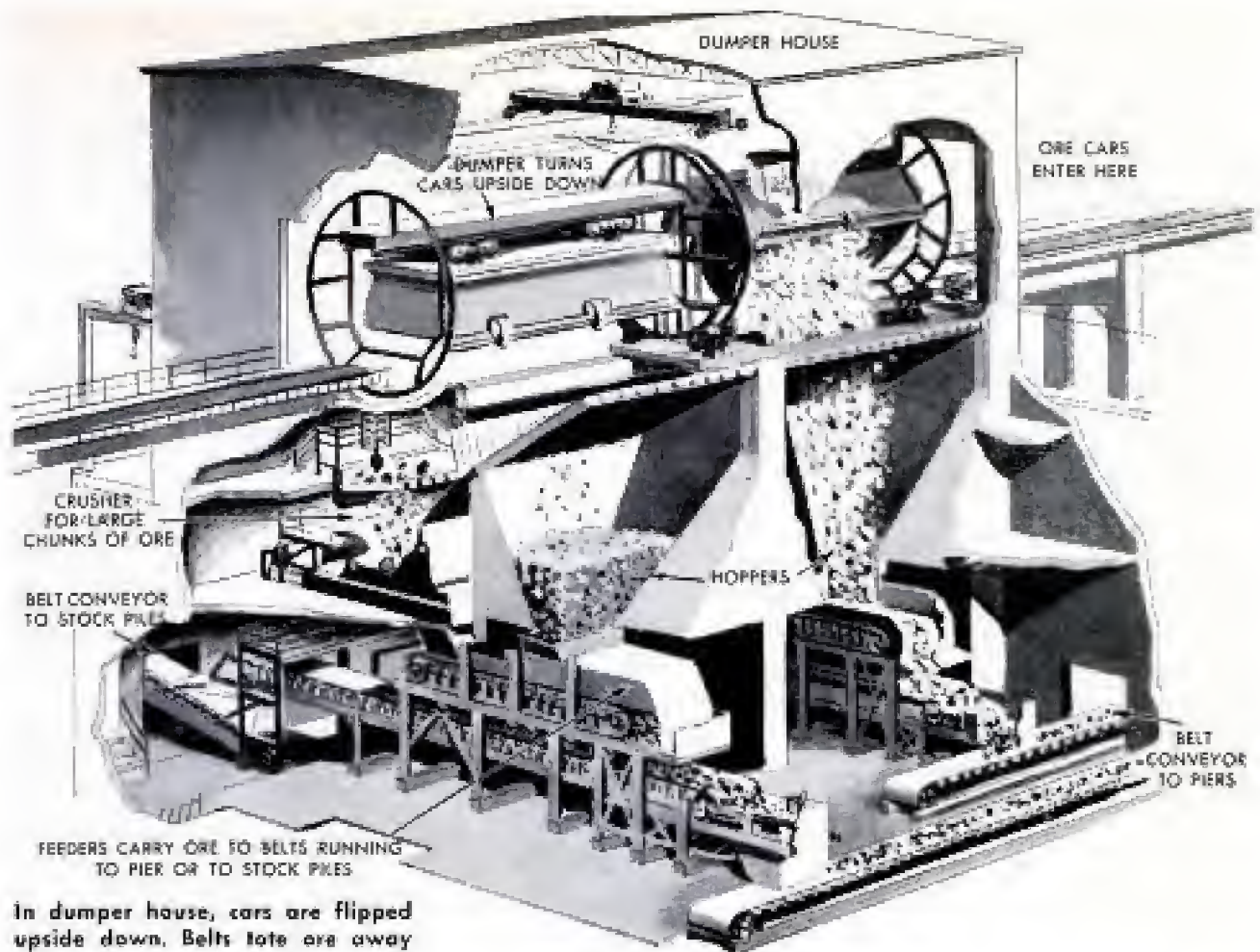

In dumper house, cars are flipped upside down. Belts tote ore away

of the project, first arrived at Seven Islands they found a tiny village of 350 fishermen. It was the last northeastern outpost of civilization this side of Goose Bay. Ships unloaded right on the ice. Weasels and tractors towed initial supplies of steel and cement ashore to build piers.

But the gargantuan task was not at Sev-

en Islands. How do you get heavy mining equipment and materials nearly 400 miles deep in a no man's land of lakes, swamps and deep muskeg incapable of supporting a bicycle?

IOC's general manager, William Durrell, hired a big, square-jawed airman named Charlie Hoyt. Durrell and Hoyt had

Trucks roll up the spongy highway carrying prefabricated houses. Tractor stands by to pull them from mud

John Rodriguez photo





Huge machine used for spreading ballast along the tracks doubles in winter as railroad snowplow, cutting through 10-ft. drifts with steel "wings" that stretch out 25 feet on either side



John Rodriguez photos

Big scraper is loaded aboard a flying boxcar at Seven Islands for a flying journey to the railroad builders far up the line

worked together flying in the materials that built Goose Bay during the war. Now they were teaming up again to turn the same trick on a railroad. Within weeks, Hollinger Ungava Transport—biggest, most sustained civilian airlift in history—was born. Hoyt's planes, carrying men and monster machines, began to roar out of Seven Islands to the hinterlands. First to fly were PBVs that could land on the lakes until strips were built. Giant "cats," hauled up in parts and reassembled in the bush, gouged 10 4000-foot landing fields from the muskeg at about 30-mile intervals along the proposed right of way.

At Wacouana (Mile 100), men faced a raging blizzard to build a strip in exactly 10 days. During this operation, Hoyt's pilots flew ceaselessly through fog, sleet, snow and rain, carrying 2,400,000 pounds of fuel, food, Caterpillars, graders, scrapers and prefabricated housing to the frigid site. The strip, built in a deep valley, requires an S-curve approach.

"We added an extra item to the landing check list here," one pilot reveals; "Wheels down, wing tips clear of mountain." Planes generally scoot up the Moisie River Valley for the first 100 miles, peaks towering above them on each side. Appropriately, the pilots call it "submarine flying."

Today the airlift is still roaring up and down the line between Knob Lake and Seven Islands. From his headquarters field at

(Continued to page 260)

Camp at Burnt Creek is a row of log buildings on a dirt street. At left is big outcrop of rich iron ore



## Quickly Donned Plastic Coveralls Protect Dress Clothes from Grease

Vinyl-plastic coveralls that don't let grease penetrate to clothes beneath are ideally suited for the home mechanic. Quickly slipped on, zipped up the front and belted, the coveralls protect dress clothes from all dirt and stains. The material is light, strong and impervious to chemicals.

## Vacuum-Canned Milk Retains Fresh Taste

Through a new process, whole fresh milk can be canned without giving it a cooked taste. The process involves keeping the milk at various temperature levels for specified periods of time. The milk is pasteurized, then homogenized at 163 degrees F. It is poured into cans at the pasteurization temperature. When the cans are almost full, jets of dry steam are directed against them. This puts a vacuum in the cans, which are immediately sealed. The temperature then is raised to about 240 degrees. The process, according to the inventor, avoids cooking the milk while raising its temperature to destroy bacteria.

## Posthole Digger Makes Square Cut

Want a square hole dug? Then you'll be interested in a device recently shown at the London Inventors' Exhibition. Used mainly when fencing land, it can cut holes from 4½ to 18 inches square.



FEBRUARY 1954



## Cartridge Prevents Rust In Fuel-Oil Tanks

Rust can't occur in a fuel tank into which has been dropped a plastic cartridge which contains acid-neutralizing crystals. Neither the plastic shell nor the crystals are soluble in any petroleum product so they cannot affect the burning of the fuel. The crystals neutralize the dilute sulphuric acid which results from the combination of water and petroleum. One cartridge will neutralize the contents of a 1000-gallon tank for a year. In addition to use in oil-burner fuel tanks, the neutralizer is also used in automobile, truck and boat gasoline tanks.





Glenn L. Martin photos

## Pivoting Bomb-Bay Door Permits Accurate Drops at High Speed

Use of a new pivoting bomb-bay door may enable jet bombers of near-sonic speeds to make their target runs without slowing down. Opening the present style doors at high speeds leaves the entire bay area a yawning chasm, causing severe buffeting from gusts and making the airplane unstable as a bombing platform. Turbulence has caused the bombs to fail to fall, presenting a hazard to the aircraft as they "float" in the bay cavity. Developed by the Glenn L. Martin Company, the new door

rotates 180 degrees just prior to the bomb release and leaves no open bay space for buffeting winds. The door is preloaded and fitted into place so that it revolves on trunnions at the front and rear ends. Two air-actuated plungers thrust each bomb or cluster into the airstream in normal dropping position. If 4000-pound block-buster bombs are used, two can be carried externally on the bottom of the door. After they are released the door can be rotated to release smaller bombs carried internally.



## Doorless German Car Features Tip-Up Top

Doffing its top to allow its owner to enter or leave, an automobile built by German mechanic Gustav Weinert is the last word in simple design. Absence of doors and similar items makes for light weight (770 pounds) and low gasoline consumption. Product of a year's work, the eight-foot car is powered by a rear-mounted motorcycle engine and runs on motor-scooter wheels. The top is lifted manually by handles at the rear or by a foot lever under the dash.

Information not listed on articles in the Index frequently is listed in the WHERE-TO-FIND-IT LIST, which is available to readers without charge from Bureau of Information, Popular Mechanics, 200 East Ontario Street, Chicago 11

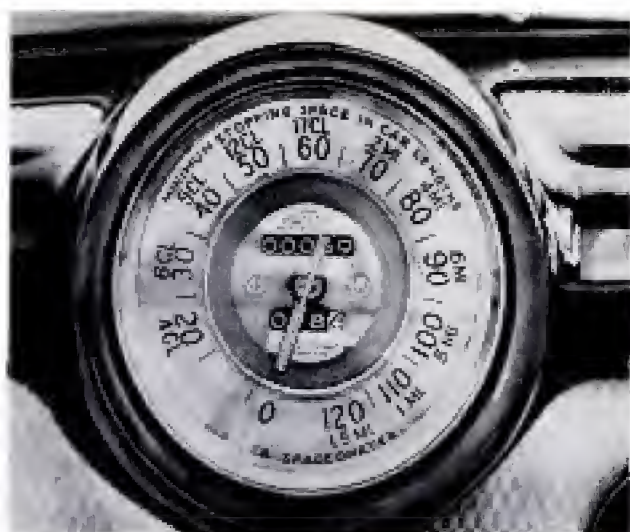

### "Stop Space" Speedometer Shows Minimum Distance

Drivers can see how much distance is required for stopping at whatever speed they are driving when they have a new speedometer dial in their car. The usual miles-per-hour numerals are retained and above each figure is given the minimum stopping distance in car lengths. Starting with 70 miles per hour, the distances are given in miles. For instance, at 110 miles per hour, it will require a full mile to stop the car under normal conditions. At 50 miles per hour, the car will travel 12 car lengths before coming to a complete halt. Invented by a Baltimore man, the Spaceometer, as it is called, is designed to show drivers the hazards of high speeds.

### Race-Car Decals

Full-color decals of famous race cars and drivers offer a new way to decorate glassware and furniture. Big track cars, sprint cars, midgets, stock cars and sports cars are included in two separate sets of six decals each. Each decoration is about four inches long, easy to transfer and washable.



FEBRUARY 1954

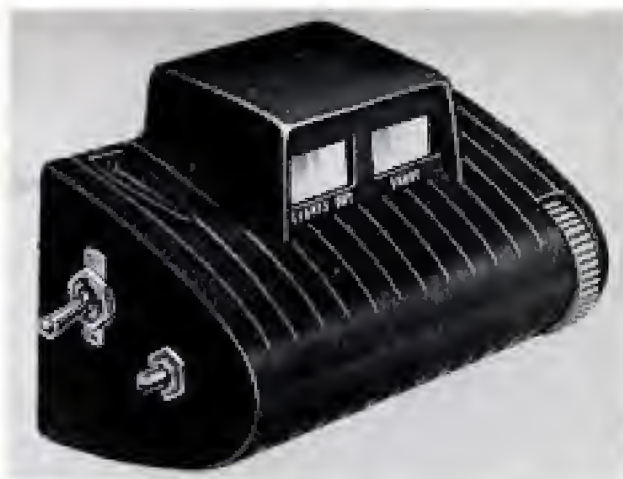

### Light Monitor Warns Driver

When trouble develops in marker lights on trucks, trailers or buses, a dashboard device warns the driver. A single red flash when the marker lights are turned on indicates perfect operation. Red and amber lights signal if a short circuit develops or more than one light fails, and a red floodlight beneath the truck turns on. A manual switch operates the floodlight during fog. A second switch controls a light which tells other drivers that it is safe to pass.

### Brake-Fluid Indicator

Hydraulic fluid in automobile brake systems is checked at a glance with an indicator that looks like an upended fruit jar. Mounted beneath the hood of an automobile, the jar is connected by a hose to the master hydraulic cylinder and acts as a reservoir for the fluid. When fluid level in the jar drops, it's time to inspect for leaks.



127

Copyrighted material



Doyle's photos

Stapling hammer used by roofer speeds job by driving a three-quarter-inch galvanized staple with each blow

# DO IT WITH STAPLES

By Thomas E. Stinson, Jr.

**G**ROWN-UP VERSIONS of the same stapler you use for fastening together a few sheets of paper are now performing a thousand and one jobs. Within limits, the new stapling devices are replacing glue, nails, tacks and other fastening methods for many tasks at big savings in time.

One small desk stapler that can tie 32 sheets of paper together is equipped with a slide that removes a staple, when desired, without tearing the paper. Unsnapped from its base, the same stapler may be squeezed between fingers and thumb for stapling lunch bags, assembling party decorations and repairing toys. Unhinged, it becomes a tacker that fastens weather stripping securely around doors and windows or tacks new shades to their rollers.

A more powerful hand stapler

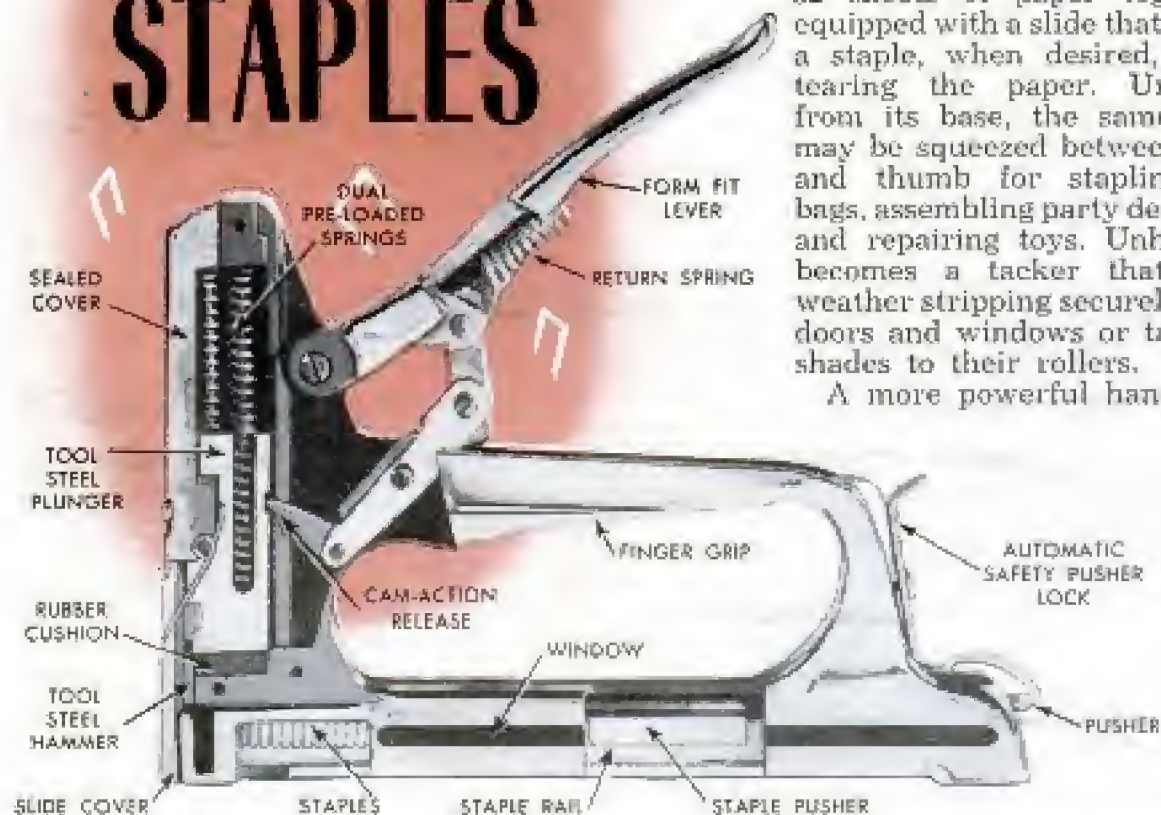



Versatile desk stapler performs all the jobs shown on this page. Above, tacking paper to kitchen shelf



Making party decorations, such as decorating paper plates above, is a cinch when you use desk stapler



Anybody who has ever tried to tack a new shade to a roller will find the operation easier with a stapler

Removed from its base, the desk stapler can be used like a pair of pliers for fastening the lunch bag

The small stapler is also handy for making repairs to furniture. It will also fasten screen to a frame

*Bostitch photo*





Hand stapler with cutout nose is used for training vines along a wall without injury to the plant

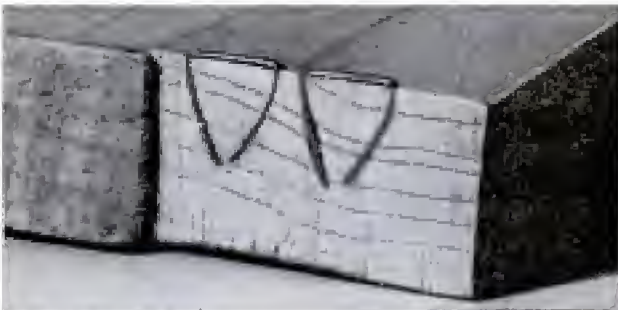

Heller Company photo

Chisel points on staple legs bring legs together with a light clinching action as they enter work



Bone surgeons have used stainless steel staples to hold fractured bones together as shown by X ray

When it comes to fastening ceiling tile in place, a stapler does a neat job without marring surface



tacks screens to doors, insulation to ceilings, shrubs to walls, plywood subflooring to its stringers and fastens metal lath. This "gun" type of tacker contains a powerful spring that is compressed as you tighten your grip on the handle, thus moving the operating lever. At the end of the squeeze the spring is released, driving down a plunger that forces the staple into the work.

Staples up to half an inch long embed themselves so firmly in wood that they are difficult to remove. Even this grip is improved in special designs that use chisel points so that the legs of the staple are driven together, or apart, as they enter the material. Some staples are shaped like a heart, open at the bottom. The top flattens out when it is driven and the points at the bottom come together.

One design of stapling tacker has a cut-out nose and is used for installing telephone and other low-voltage wiring. Its wide, decorative staples are easily driven into wood, plaster or stucco. Another type drives diamond points instead of staples and is used for securing window glasses in wooden sash. Still another type is used by florists in assembling bouquets.

Staplers that are built on the "wrap around" principle form the wire rings used in assembling automobile seats, mattresses, wire pens, tying necks of plastic bags for frozen-food storage and binding assemblies of loose wiring.

One manufacturer has designed a tiny stapler, enclosed in a jeweled container, for emergency repair of clothing. At the other end of the stapler line are big automatic high-speed stapling machines that assemble shipping cartons or stitch together some of the subassemblies of stoves, automobiles and aircraft. Some 800 different designs of stapling machines are manufactured and it is estimated that a billion staples a day are used in fastening together the things that America uses.

Some high-carbon staples can be driven through a half inch of hardwood or a lesser amount of metal. One favorite exhibit of some manufacturers is five copper pennies fastened together by a single staple.

Modern stapling devices trace their origin to an improved wire-stitching machine called the Boston wire stitcher that was developed by Thomas A. Briggs around the turn of the century. These stitchers, still widely used today, form their own staples from a spool of wire. The pages of this magazine are bound together by staples produced in this way.

Already tried on an experimental basis is the idea of fastening fractured bones together with stainless-steel staples. Other staples eventually may tie up blood vessels during an operation. ★ ★ ★



## Radio Automatically Times Cars at Indianapolis Speedway

Race cars may soon be equipped with a miniature radio transmitter that provides a foolproof and precise means of clocking speed and elapsed time. The unit, recently tested at Indianapolis Speedway, eliminates all chance of human error. There are two components involved. The basic unit is a receiver which operates a recording device and is mounted at the finish line. In addition, each car carries a tiny transmitter that sends out a signal on its own individual frequency. Every time the car passes the finish line, the transmitted signal actuates a recording machine that counts the number of laps and records the elapsed time of each. On the original trial runs, the equipment was fairly cumbersome, but a new design has been developed with a transmitter for each car no larger than two packs of cigarettes and requiring no protruding antenna. The



Mounted on bumper is the test transmitter of timer unit (arrow). Top arrow points to receiver unit. New design is much smaller

trackside receiver can be built into a box only four inches on each side, states the designer, Lee Evans.

## Doped and Frozen Fish Withstand Transfer to New Home

Drugs and chopped ice helped solve a transportation problem when 1110 lake trout were flown to an isolated lake in Canada's Prince Albert National Park. Because it was not practical to carry the lively five-pounders in sloshing tanks of

water, they were first placed in water containing an anesthetic, then packed in wooden boxes and covered with ice. Loaded aboard a plane and flown to the lake, they were left in a floating reservoir from which they escaped as they recovered.

## Engineer Is Safe in Steel Wire Cage Charged With 300,000 Volts

Even though a 300,000-volt electric current surges through the steel-wire ball which encloses him, an engineer in a Munich museum demonstration remains unperturbed. The so-called "Faraday's cage" protects its passenger even though he's in the midst of a powerful electrostatic field. The electricity spreads harmlessly around the ball and is then grounded via a cable.

## Electronic "Nose"

With a sensitivity far greater than that of the human nose, an electronic sniffer can detect sulphur in concentrations as low as one part to 10,000,000 parts of air.



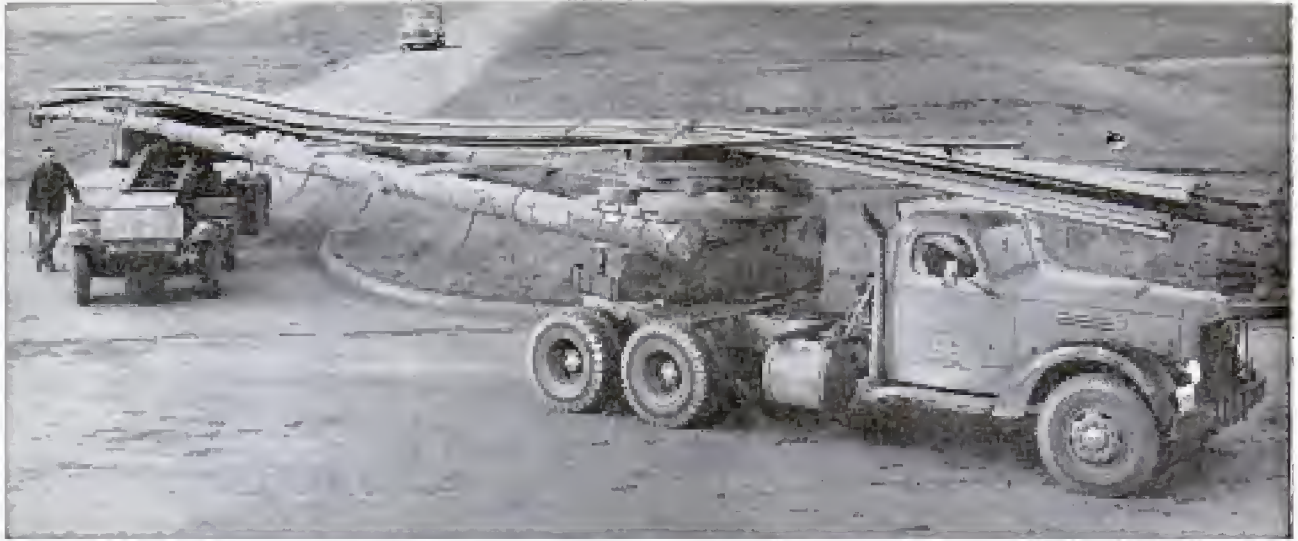

### Tag-Along Trailer Supports Rear End of 88-Foot Load

When a Portland, Ore., concern was given the job of hauling 88-foot lengths of heavy reinforcing steel over the highways, it neatly solved the problem of getting the lengthy cargo around corners. Sixty-eight-foot-long poles, to support the steel,

stretched from the tractor to a separately steered trailer made up for the job from an old truck. Poles and steel were lashed to the pivoting beds of the tractor and trailer and together acted as a tow bar. The trailer driver was 40 feet behind the truck.

### College Students Build Rig and Drill Oil Well Without Expecting Gusher

Petroleum engineering students at Orange Coast Junior College, Costa Mesa, Calif., have built their own oil rig, complete with drills, pipes, blocks, a mud pump and other items of drilling equipment. The idea behind the rig is that students can't learn to drill oil by reading books. The school is planning to tear down, move and

rebuild the rig each year to give every class a chance to drill a well. The class is incorporated under state laws, not only to drill but also to go through the financing of an oil company. According to plans, a thousand-foot hole will be dug each year. It will be only a practice run—no one really expects to hit a gusher.

Experience is the best teacher: Students swarm over their rig in learning to handle the oil-drilling equipment

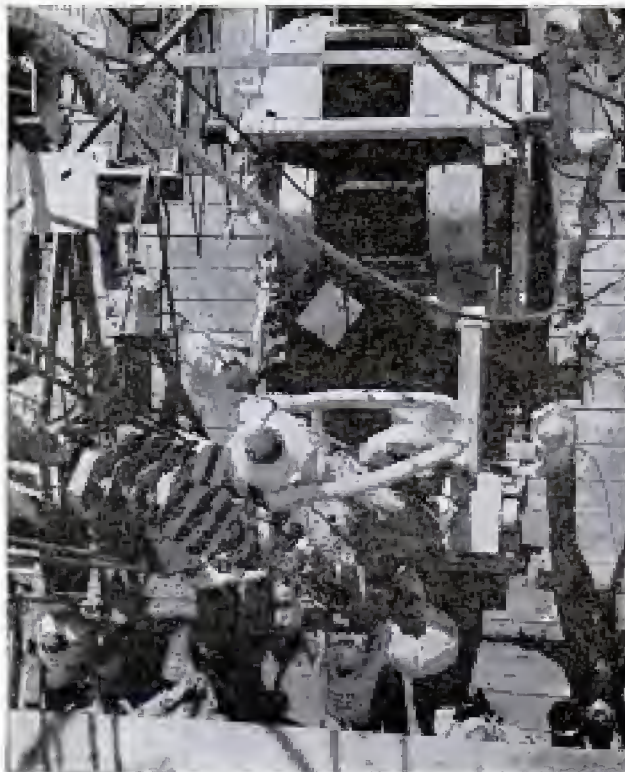

## Midget Gas Turbine Helps Run World's Largest Cargo Airplane

Weighing less than 100 pounds and about two feet square, a gas turbine engine that delivers 50 horsepower provides power for generator sets in the giant Globemaster transports. The sets supply auxiliary and emergency power, either on the ground or in flight. The engine is the world's smallest of its type and the Globemaster is the world's largest cargo and troop-transport airplane.

## Snails Enrich Feed

Giant African snails, major pests in warm parts of the world, may prove useful after all. Dehydrated and reduced to a powder, they boost the protein content of livestock feed.



Douglas Aircraft Company photo



## Hydraulic Four-Wheel Drive Operates German Bus

For more than two years, a bus company in the American zone of Germany has been operating a bus without a transmission, differential or drive shaft. All four wheels of the bus are power driven. Oil is the propelling medium and it is piped under pressure into separate "oil motors" in each of the wheel hubs. A large oil pump, attached to the engine, provides the pressure and the oil does the rest. There are several advantages to this method of drive: The oil motors can be used as brakes by reversing the valves, converting them into pumps. A trailer can be powered simply by the use of a flexible-hose connection between the tractor and trailer. In addition, engine and pump can be put anywhere in the vehicle without loss of efficiency.

Oil motor, left, encircles axle. Oil surging through pockets between inner and outer cog wheels causes inner wheel to spin. Below, diagram of the system

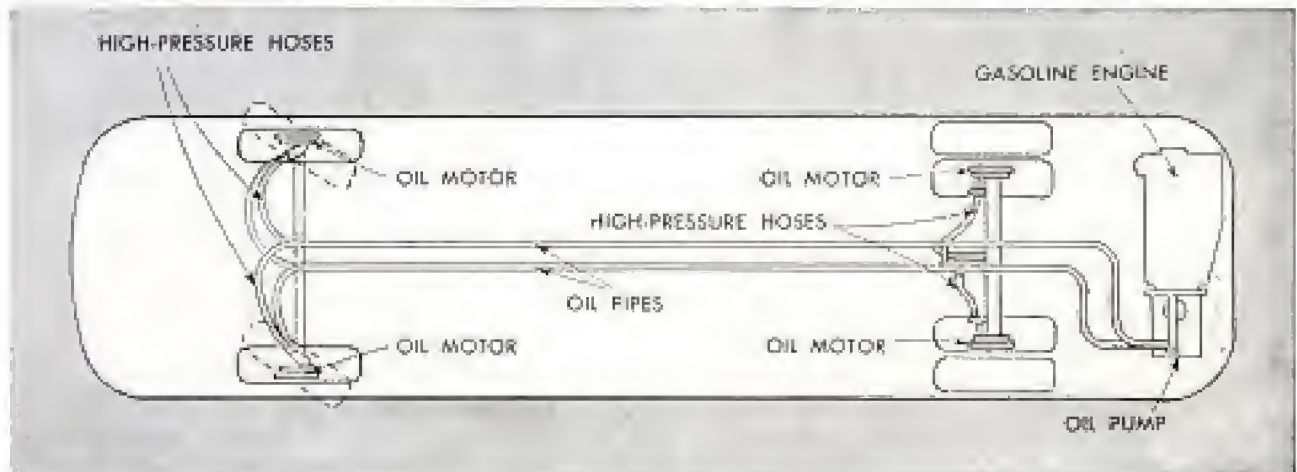

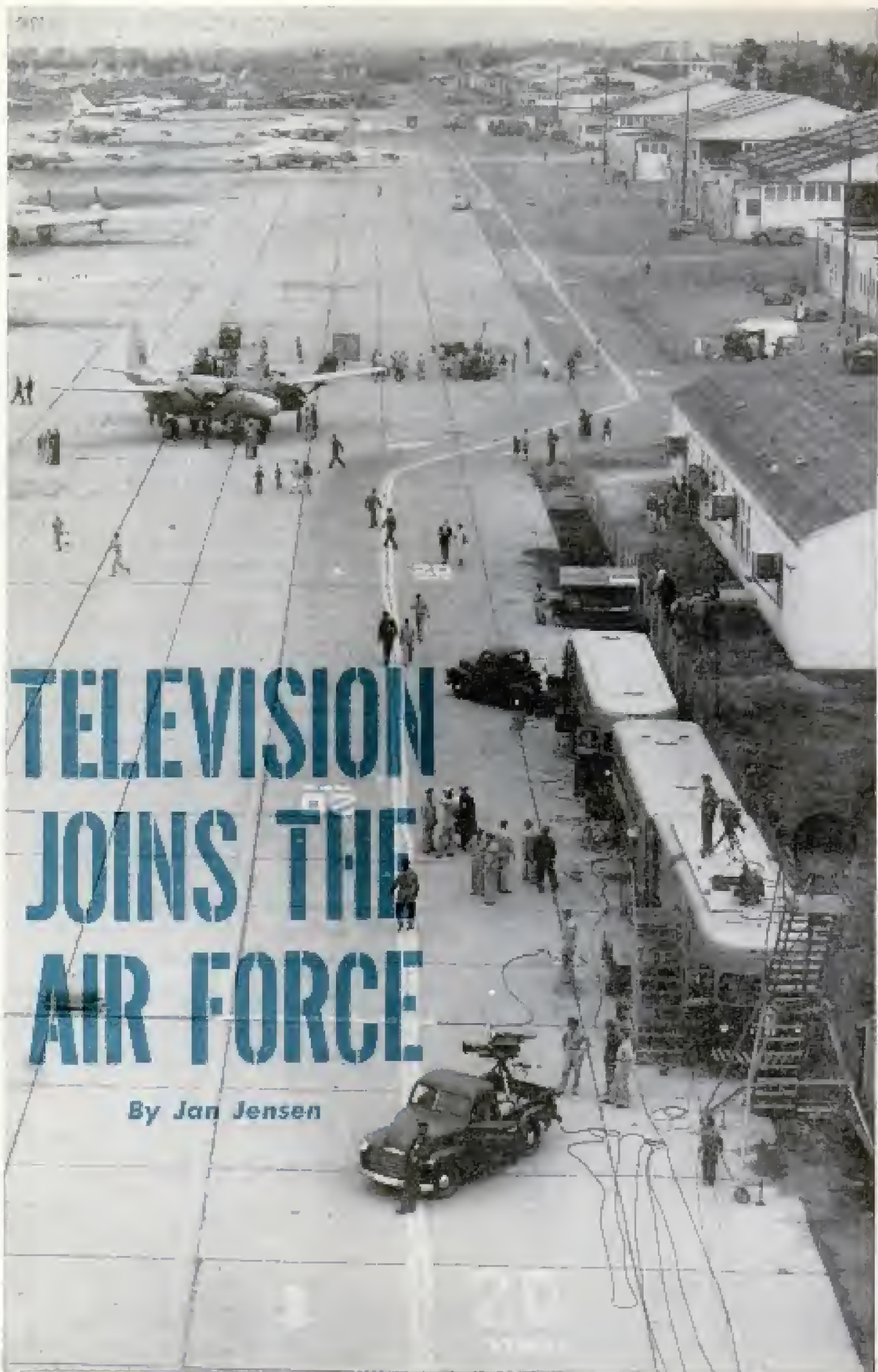

# TELEVISION JOINS THE AIR FORCE

*By Jan Jensen*

**A**LTHOUGH THE AVERAGE TV fan may be of the shirt-sleeve variety, settling down to watch the fights after the kids have relinquished the set for the evening, at a special experiment not long ago at Hamilton Air Force Base in California, the viewer wore a pilot's blue uniform and the program was a command performance exclusively for him. A preview of what may soon be normal procedure, this first tactical use of television in the United States Air Force was made by broadcasting weather briefings to seven different points on the base and, with the aid of a microwave-relay link, to a radar center 10 miles away along the Marin County coast.

So successful were these tests that soon a pilot may seat himself in the alert room at the end of the runway, call the base weather operations a mile away and say, "Give me a winds-aloft report. How does it look between here and Portland?"

Then, as a weather map and a forecaster appear on the screen in the television receiver before him, he will scrutinize each chalked arrow and follow the moving pointer designating various areas as they are explained. "It's pretty solid at 4000 here over Spokane," he may be told. "Better take it at 8000, but after that, through this coastal area, you'll find there's a better tail wind around 6500."

During the several weeks in which the televised weather briefings to pilots were demonstrated, it was proved that 30 minutes in time was gained over telephone, teletypewriter and radio. The 1354th Video Production Squadron established the weather station at the San Francisco base. Since July 1952 when it was organized, this mobile unit, the only one of its kind in the Air Force, has been busier than a three-minute car wash. Its shiny silver and gold-trimmed trucks, the Air Force insignia encircling a TV camera on their sides, called the Lockheed Air Terminal at Burbank, Calif., their home diggings for the first year.

As a grand finale to their stay on the Pacific Coast before rolling forward to new tactics in Florida, the squadron pulled its three huge



U.S. Air Force photos

During a telecast, the audio engineer is in the foreground and the video engineer and technical director are seated at the video console. Equipped with a Zoomar lens, camera mounted atop a truck provides wide-angle or close-up views of action





Robert B. Jensen photo

Four TV cameras on rolling casters shoot on-the-spot kinescope of an aircraft fire-fighting demonstration

vans into the lower concourse of CBS in Hollywood and proudly showed the visiting convention from the Society of Motion Picture and TV Engineers what they had accomplished in one short year.

"The unit," announced a smartly uniformed WAF, "is made up of three 35-foot motor vehicles, one of which is the engineering bus, another for power and the third for personnel."

Climbing the steps of the engineering truck, a visitor is impressed with the elaborate video and audio-control system installed in its compact interior, so complete it would do credit to a major network. At a control console there are the master video and four camera monitors. Directly to their left are the distribution amplifiers used to feed a composite picture as well as the driving pulses, created by a synchronizing generator, to the cameras, all the picture monitors and other equipment used in the television system.

"Above the amplifiers," pointed out the guide, "is the video patch bay, consisting of short pieces of flexible 'coax.' To the left is a very accurate cathode-ray oscilloscope, which is used to measure the magnitude and shape of the picture and 'sync' pulses. Here, in this bay, the video man manipulates the intricate controls and creates a television picture by adjustment of various picture shading, focus, gain, beam and target controls. An interesting feature is the flying-spot scanner-projection equipment located here, which converts a still slide or motion-picture film back into a video

signal which may be faded into or mixed with another TV picture. It permits titles to be superimposed over live pictures."

In the center of this truck is the tape recorder, directly behind the audio-mixer console. Most of the programs are recorded on 16-mm. motion-picture film with an optical sound track and magnetic tape used for an audio-protection copy. The tape machine is driven by selsyn motors coupled to the kinescope camera. After the film is exposed in the special camera, focused on a high-brilliance television-kinescope-picture tube which is at the rear of the truck, instead of winding up on a take-up reel, it is transferred directly through a light-tight tube to the rapid film-processing machine, which develops and dries the film as fast as it comes from the camera.

Within 60 seconds after a scene is televised, it emerges from the processor as a dried, ready-to-project motion-picture film.

Two giant, gas-driven 25 and 15 kilowatt generators, capable of producing 40,000 watts of power, provide all the electricity needed for a television production, with enough storage space for cable, microwave, lighting and other portable TV equipment. The microwave transmitter and receiver, which are used for field pickups where coax cable is not feasible, are huge parabolic "dishpans" with wave-guide button-hooks in their centers. They operate in a frequency band between 7100 and 7150 megacycles.

A personnel mobile unit carries production crews, with a compartment that may



With the camera in for a close-up, an instructor explains the workings of an airplane engine to a TV audience

be used as a small studio, writers' office or a conference room.

The 1354th Video Squadron has delved into every remote possibility of their over-all mission, which is to provide any television services that may be required by the United States Air Force, until its 42 officers and 62 airmen are as familiar with each part and technique of the unit as old-timers are with local history.

"At present," says Lt. Col. Mel Williamson, commanding officer of the squadron, "our purpose is more for training and education. We have found in the groups we have tested, instruction by this method chalks up 85 percent as efficient as the best face-to-face teaching. The average 18-year-old enlistee is more accustomed to watching TV than the movies and is more attentive to this medium. Another, it saves time and money to assign a television mobile unit to one basic-training school, obtain the very best instructor possible, and either feed live TV programs of the curricula by use of the coax cable to an unlimited number of groups, or else make kinescopes to be used over and over again anywhere at other training posts. Kinephoto recordings are much cheaper than films

(Continued to page 268)

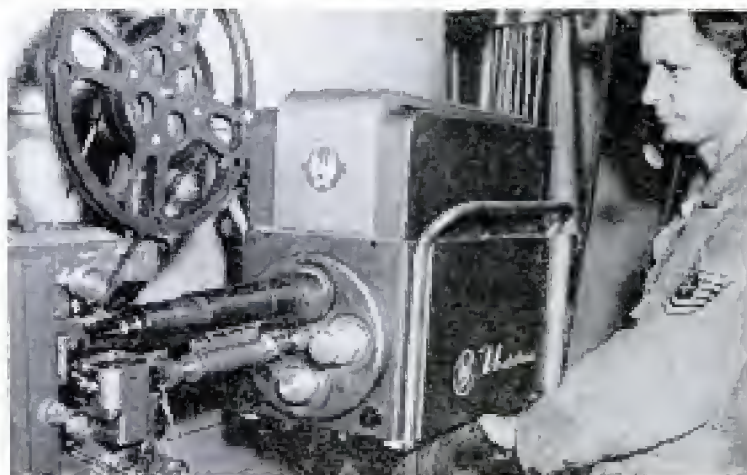

Reproduction of a 16-mm. film is accomplished by feeding the projector into a TV camera. Below, a pilot receives weather information and flight instruction by television during the experiment at Hamilton Air Force Base. Tests proved method is at least 30 minutes faster than teletypewriter, radio or telephone





Left, new shell mold is taken from machine. Right, casting from matched plastic molds is clean and smooth

## Mold-Making Machine Cuts Costs 30 Percent

By refining a process developed in Germany, a group of graduate students at Stanford University turn out shell molds at 30 percent less cost than the old way and castings made in the molds are cleaner and have closer tolerances. The method involves a sand-and-plastic mold that has been successfully used in large production runs, but had never been considered practical for small foundries. The molding machine has a hot oven at one end and a bin

containing sand and a thermosetting plastic at the other. The metal pattern from which the mold is to be made is heated in the oven, turned upside down and then clamped to the open top of the sand bin. The whole bin is then inverted and the sand-and-plastic mix falls on the hot metal pattern. Heat from the pattern sets the plastic and causes a layer of the mixture to stick to the pattern. When the bin is inverted again, the mold is lifted off.

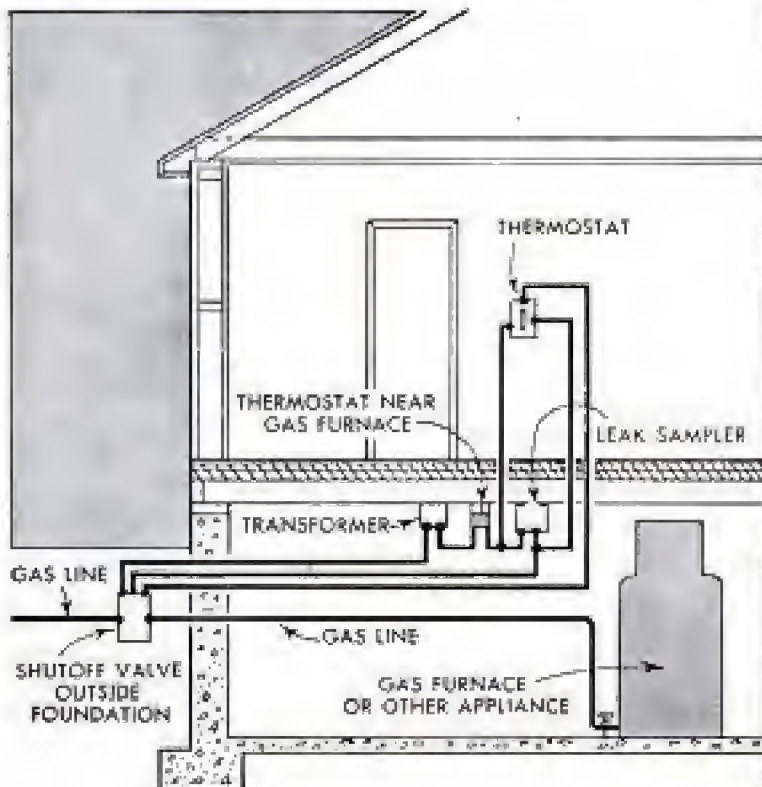

## Automatic "Sniffer" Detects Leaking Gas

Gas leaks inside the home are quickly detected by an automatic "sniffer." The detector is located in the basement or any room where a leak might occur. An electric pump samples the air at regular intervals, and if any trace of gas is present the system immediately sounds an alarm. In event of a fire it closes a shutoff valve in the underground gas main outside the foundation as soon as the temperature reaches 110 degrees.

Sources of available products described in this issue are listed on pages 16, 20 and 22. Sources of further information on other articles are given in the WHERE-TO-FIND-IT LIST, available from Bureau of Information, Popular Mechanics, 200 East Ontario Street, Chicago 11



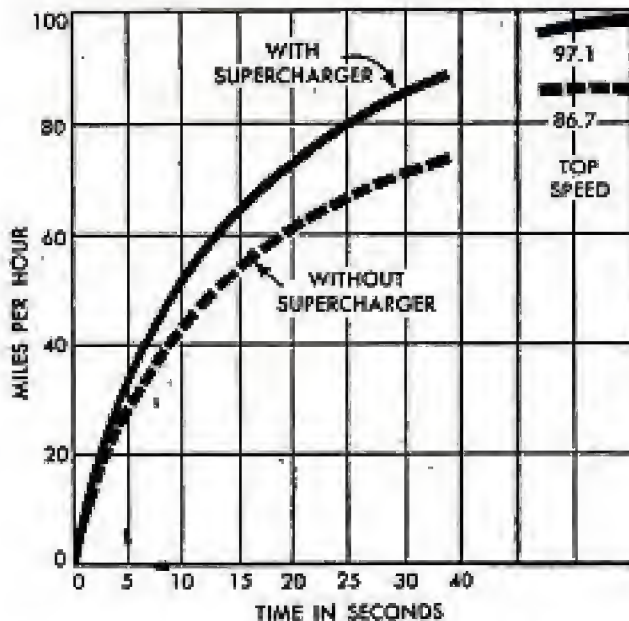

Curves mark acceleration and top speed of Mercury test car before and after supercharger was added



Unit is mounted ahead of carburetor and driven by fan belt. It is assembled from kit, quickly installed

## Variable-Speed Supercharger for Stock Cars Boosts Power

You can make your stock automobile perform like a hot rod by installing a variable-speed supercharger that is said to add as much as 40 percent to engine power. Acceleration and top speed are materially increased. The unit is also useful in high-altitude areas as it provides sea-level performance at mile-high elevations. It is

of the centrifugal type, driven by the fan belt and mounted ahead of the carburetor. A variable-speed feature permits the unit to stand by until the throttle is depressed. Said to be virtually silent in operation, it comes complete with an installation kit and can be installed in the average car in a few hours.

## Elaborate Mechanism Works and Works to Do Nothing Well

We all know someone who works harder doing nothing than most of us work doing something, but we can't possibly know anything that works harder at nothing than a machine built by a California hobbyist. The machine has over 700 working parts that rotate, twist, oscillate and reciprocate—all for no purpose except movement. It is the brainchild of Lawrence Wahlstrom, a landscape artist, who calls it a flying-saucer detector. The machine not only accomplishes nothing, it is never completed—it has been under construction seven years. Each year Wahlstrom adds 50 or more moving parts to it so it can do nothing more efficiently!

Motorists will get 40 percent more miles per gallon in the near future when engines with 12-to-1 compression ratios requiring 100-octane gasoline become available, predicts Dr. Gustav Egloff, noted petroleum scientist.

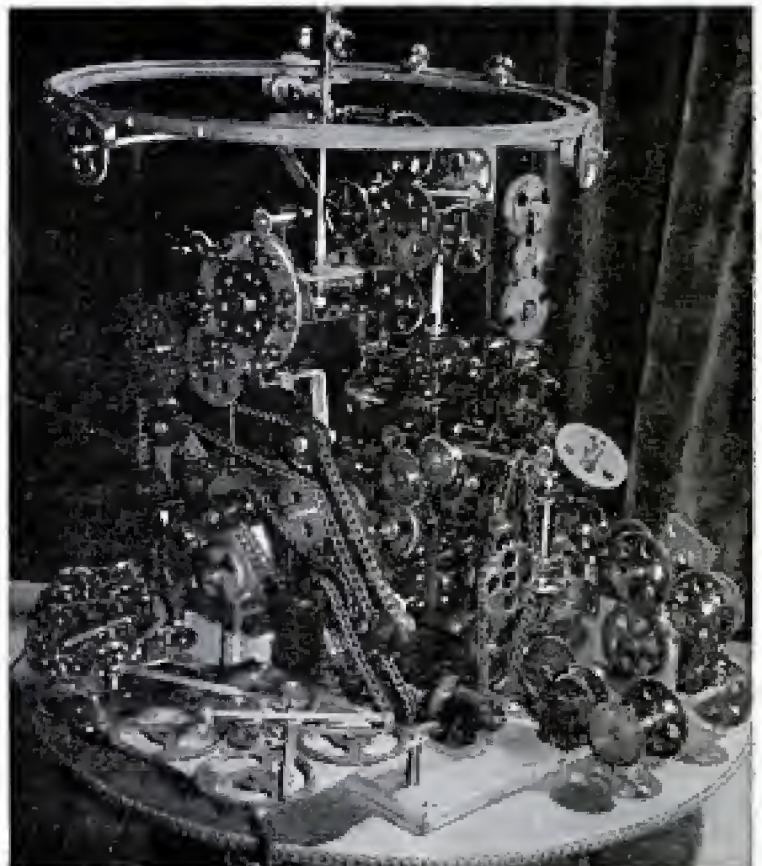

# IVAN, THE RETROACTIVE



*Busiest inventor behind the Iron Curtain, we think, is the fellow who invents Russian inventors who beat our Benjamin Franklins and Thomas A. Edisons to the bright idea. This article, based on items in the soviet press, was compiled by Crusade for Freedom correspondents. Through the Crusade, millions of private Americans support Radio Free Europe and provide information and leadership to the peoples of Czechoslovakia, Poland, Hungary, Rumania, Bulgaria and Albania. We hope there is a sense of humor left in Moscow.*



**A** NEW RACE of supermen has been invented: men of such fantastic intellectual capacities that they do rocket research at the age of eight. This race is Russian and anyone who doubts it just hasn't been reading his *Pravda* lately. For if he had, he'd know that almost everything ever invented—except, to date, man and the wheel and fire—was the sole product of the Russian state.

Nobel had nothing to do with dynamite, the soviet press assures us. He only stole



the patent from Messrs. Zinine and Petrusovski, who invented it, along with nitroglycerin, in 1863. Marconi stole the radio from Popov, and Ben Franklin, that sly thief, never invented the lightning rod at all. Professor Lomonosov patented it much earlier and Franklin stole the patent in 1752. Lomonosov, a real producer, also invented the first helicopter model, later developed by Zhukovsky in 1912. The Wright brothers were more than 25 years late with their airplane, for Alexander Mozhaisky patented that in 1875, developed a steam-propelled airplane in 1882 and also was the first to develop amphibious aircraft and the aileron.

Television was first invented in 1907, when Russia's Boris Rosing invented cathode telescropy. Cyrus H. McCormick had little to do with the combine and harvester, for a Russian agronomist named Vlasenko developed one "20 times better 11 years earlier." Sir Arthur Fleming, a British fuddy-duddy, the soviet press assures us, was a full fifty years late with penicillin

when he invented it in 1928. As a matter of fact, the anonymous Russian scientist who invented penicillin based his discovery on a "near-penicillin" of two Russians in 1870. This 19th century penicillin was "so excellent" that another Russian scientist (also strangely unnamed) used it on a couple of unprotesting chickens in 1904. What happened to the birds is not revealed in the report.

The soviets don't blink an eye at some puzzling facts. For example, the Russian "inventor of the airplane," Comrade Mozhaisky, isn't even listed in the first *Great Soviet Encyclopedia* and the latest edition of the *Short Soviet Encyclopedia* still credits the Wright brothers with the invention. Similarly, the *Soviet Encyclopedia of 1928* says "the bicycle is the invention of the following 19th century inventors: Dreis, Dallselle, Lallemand and Michelin. The pedals were invented in 1885 by the Frenchman Micheaux." Without even blushing, the 1949 edition claims the bicycle as an invention of the "Russian worker Artamanov." This intrepid fellow, listed as stemming from the Ural Mountains, bicycled 1000 miles to Moscow in 1801—84 years before inventor Micheaux climbed onto his French contraption.

The Western countries, filled with "thieves and pilferers," stole practically every single Russian invention, says Radio Moscow. Michael Lomonosov, not only the "inventor" of the lightning rod but also of the periscope, atomic energy, cosmic-ray research, the kinetic theory of gases, the mechanical theory of heat, the Law of Conservation of Energy and the use of the microscope in chemistry, would be more widely known today if it weren't for "foreign thieves of Russian inventions and pilferers of Russian glory," complains the Soviet Academy of Sciences.

If it hadn't been for these "thieves," then we might realize that it was a Russian, Fedor Abramovich Blinov, who developed the Caterpillar tractor in 1879 and that it was an American firm which "stole" his patent. We might realize that two Russians,

# INVENTOR

Gauzei and Brazhnikova, developed antibiotics in 1942, that an unnamed Russian invented DDT, that it was Czar Peter I who invented the world's first floating dry dock and the first device to measure the ocean depths, and that the Russians invented radio broadcasting, radio-sounding devices for the atmosphere, the teleprinter, telegraph poles, telegraph equipment, sound movies, movie film, photolithographic machinery, Technicolor, 3-D movies, radio location techniques, radio navigation, radio acoustics, the use of high-frequency current in industry, and vitamins. All these, of course, long before the doddering Western scientists even thought of them.

Not only are the Russians showing that they can "scoop" Western inventors; they even scoop themselves. Just a short while ago Radio Moscow announced that "until recently it was thought that the first rockets had been manufactured in Russia in 1680 when Peter I founded the rocket in-

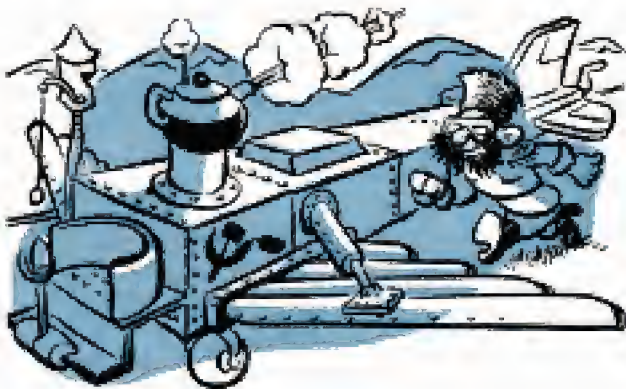

stitution. Materials found in the U.S.S.R. recently proved that the first rockets had been made in Russia at least 60 years prior to that time." It's probably just as well that they got Peter off the hook. In 1680, when he was supposed to have been vitally interested in rocket research, he was only eight years old, having been born in 1672.

Having invented almost every machine worth inventing, the Russians recently started claiming that they invented things like the "art of warfare." Statistics? The Russians were tabulating statistics back in 1727. Shakespeare? Only in the U.S.S.R. is Shakespeare performed as he was intended to be performed, says a Baku newspaper. Evolution? "Progressive Russian scientists" developed that many years before Charles Darwin, says *Pravda*. Relativity? Despite the fact that the theory of relativity is not considered correct from the Marxist point of view, *Pravda* says that a Russian named Lobachevsky stumbled onto rela-



tivity long before Professor Einstein did.

And as for the incandescent lamp, Moscow reveals that Edison is a plain and simple liar. It was the Russian, Ladygin, who developed it in 1877, despite the fact that the 1937 *Great Soviet Encyclopedia* still gives the Americans credit for it.

Lately the Russians, thinking of their satellites, have become generous. Directives must have gone out to the captive states of Eastern Europe, telling them that it would be quite all right now for them to claim a little invention or two. The Czech Reds were so happy that they threw all caution to the winds. They promptly staged an exhibition named "What Czechoslovak Technicians Have Given the World" and placed among the "discoveries"—the lightning rod.

We wonder whose head rolled when that reached Moscow. Hadn't the Czechoslovak Reds ever heard of Russia's Lomonosov?

It has become a battle royal and the field still seems wide open. Recently, Hungarian Communists insisted that the dynamo, the telephone switchboard, the telephone, the Zeppelin and the first internal-combustion engine were all invented by Hungarians.

Why all this frenzied search for scientific glory?

As *Questions of History*, a Moscow publication, recently said: "... the more rapacious and piratic the imperialism of a given country, the more insolent and crude is this (ascribing) as many scientific discoveries as possible to scholars of one's own nationality and race at the expense of all other nationalities and races." ★ ★ ★





Lincoln Electric Co. photos



## ***All the Way to China?***

BY WELDING STEEL beams on top of each other, construction engineers can drive piles to any depth to reach bed rock—theoretically all the way to China if necessary! A length of H pile is driven into the ground by a pile driver until only a few feet remain above the surface. Another length of piling then is swung into position and welded atop the driven one. What is believed to be the deepest pile ever driven supports a highway bridge near Meadville, Pa. It reaches a depth of 304 feet. The same pile-driving technique can be used on standard I-beam piles and pipe piles. The corrosion of piles in the ground is negligible.

## Pump Moves Water in Ship From Side to Side to Minimize Roll

Up to 90 percent of the roll in ships can be eliminated by an improved ballasting system devised at Stanford University. The heart of the system is an apparatus that senses the roll, and rapidly transfers water to a tank on the rising side of the ship. Weight of the water cancels the force that causes the roll, keeping the ship level. The method was devised with the aid of an unwieldy teeter-totter apparatus that represents a Navy destroyer plowing through a hurricane. Motorized springs rock the apparatus to simulate the roll of the ship and the stabilizer system quickly stops the ship's motion. The system has a pump with reversible and variable-pitch blades that transfer water from one ballast tank to another. Now ready for testing on an ocean-going vessel, the system promises more comfortable voyages and easier aircraft landings on carriers.

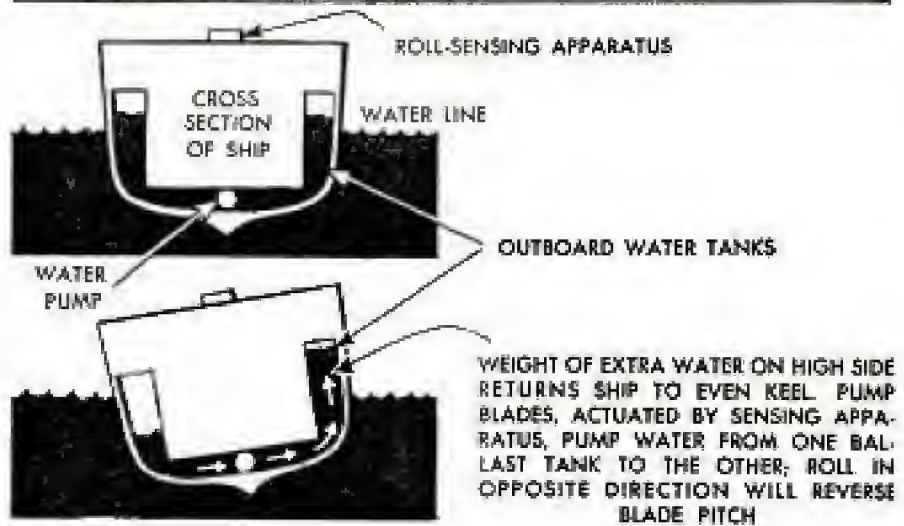
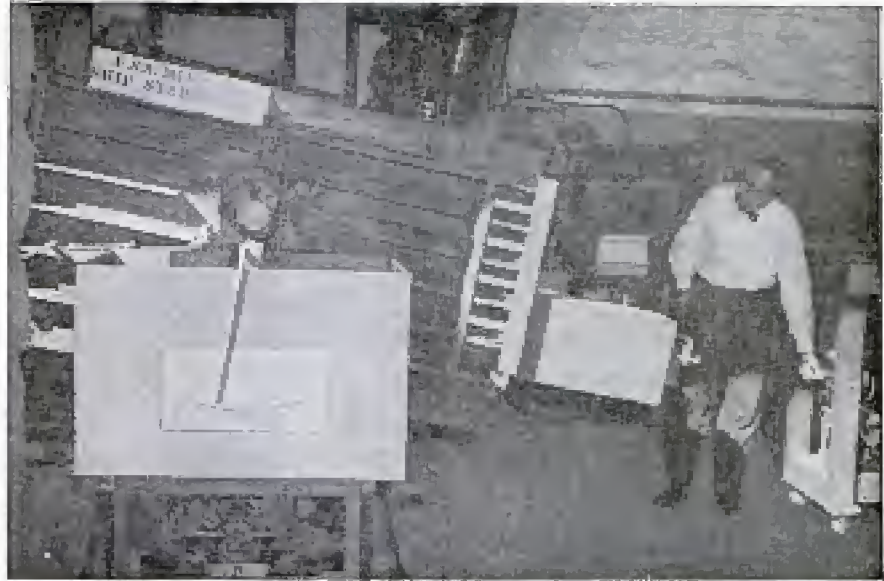

## Two-Foot-Wide Propeller Blades To Be Turned by 5500-Horsepower Engine

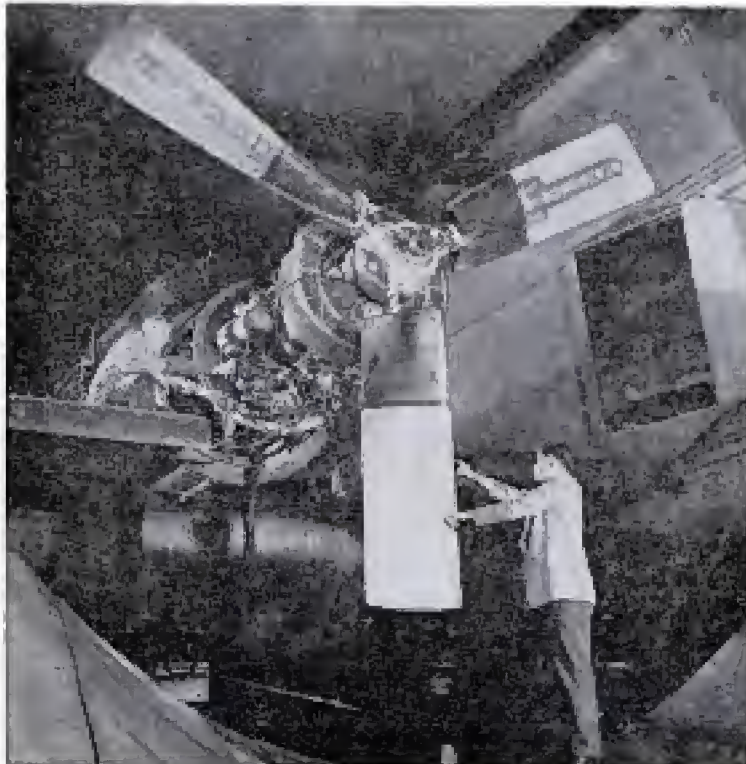

As added propulsive thrust for take-off, two-foot-wide propeller blades are being produced for Pratt & Whitney's 5500-horsepower T34 turboprop engine. The hollow steel blade is braced by a steel core, with synthetic sponge filling the air spaces to provide additional support of the shell. The widest blade previously made by Hamilton Standard was 17½ inches.

## X-Ray Pictures in Color

X-ray pictures in color may soon help doctors spot slivers of glass and other nonmetallic particles embedded in the flesh. Certain commercial color films which change the invisible energy of X rays and selected alpha, beta and gamma rays into bright visible colors would be used. The color difference makes the foreign body easy to locate.

ON THE FORTY PAGES which follow, we present a Special Section devoted to the automobile. It begins with a glimpse into a glorious past—the age of the Classic Cars, portrayed in full-color photographs and sketches worthy of framing. There follows a review of the 1954 models just introduced in America, their specifications and a pictorial commentary on the novel mechanical and style changes appearing in the new lines. Other notable articles in this section are a "Report to Detroit" on a survey conducted by the Editors of *Popular Mechanics* of what the American motorist wants in the car of the future, a graphic presentation of the basic facts of automobile mechanics and an interview with two great American drivers on the world's greatest road races. In the Craftsman Section appears another article on "How to Buy a Used Car." We present this Special Section with great pride.

THE TWELVE FINEST

# American Classics

---

## A Portfolio of Ageless Cars

BY ARTHUR R. RAILTON, *Automotive Editor*

Color photographs by Don Hanick

IN THE EIGHT PAGES which follow, *Popular Mechanics* salutes the Classics among the Classics—12 American automobiles chosen as the finest produced in that golden era defined as the period from 1925 to 1942.

Ranked in the order of their selection, the Classics are portrayed here in true color by *Popular Mechanics* photographs and sketches. The roll of honor:

1. Duesenberg 1931-J Roadster-Murphy.
2. Duesenberg 1931-J Victoria-Rollston.
3. Lincoln 1932-KB Phaeton Dual Cowl.
4. Packard 1929 Sport Phaeton.
5. Pierce Arrow 1933 Silver Arrow V12.
6. Stutz 1932 Super Bearcat.
7. Cord 1937 Convertible Coupe.
8. Packard 1930 Speedster.
9. Kissel 1927 White Eagle Speedster.
10. Auburn 1936 Supercharged Speedster.
11. Marmon 1931 V16 Club Sedan.
12. Lincoln 1941 Continental Convertible.

The years 1925 to 1942, in the minds of Classic Car fans, delineate the era in which the motor car had attained mechanical excellence, having thrown off all the heritage of the horse-drawn buggy, and had not yet passed into the hands of the stylist.

These 12 cars, honored here as pre-eminent among their kind, are no museum pieces. Proud owners still operate and maintain them, some in their original paint, certainly most in their original hue, and as much as possible in their pristine operating condition—without the multiplicity of gadgets and chrome and automatic mechanisms of present-day cars.

What is a Classic Car? It may have a thousand definitions in the minds of the Classic cultists. Surely it is not merely a "middle aged" car—something between an antique and a modern! Simply expressed, it is an automobile of enduring beauty to which is harnessed a surplus of power.

(Continued to page 153)



*Duesenberg Roadster-Murphy 1931-7*

Owner: William S. McKelvy, Pittsburgh, Pa.



**SECOND:**

*Duesenberg Victoria-Rollston 1931-J*

Owner: Dr. A. S. Fisher, Bergenfield, N. J.





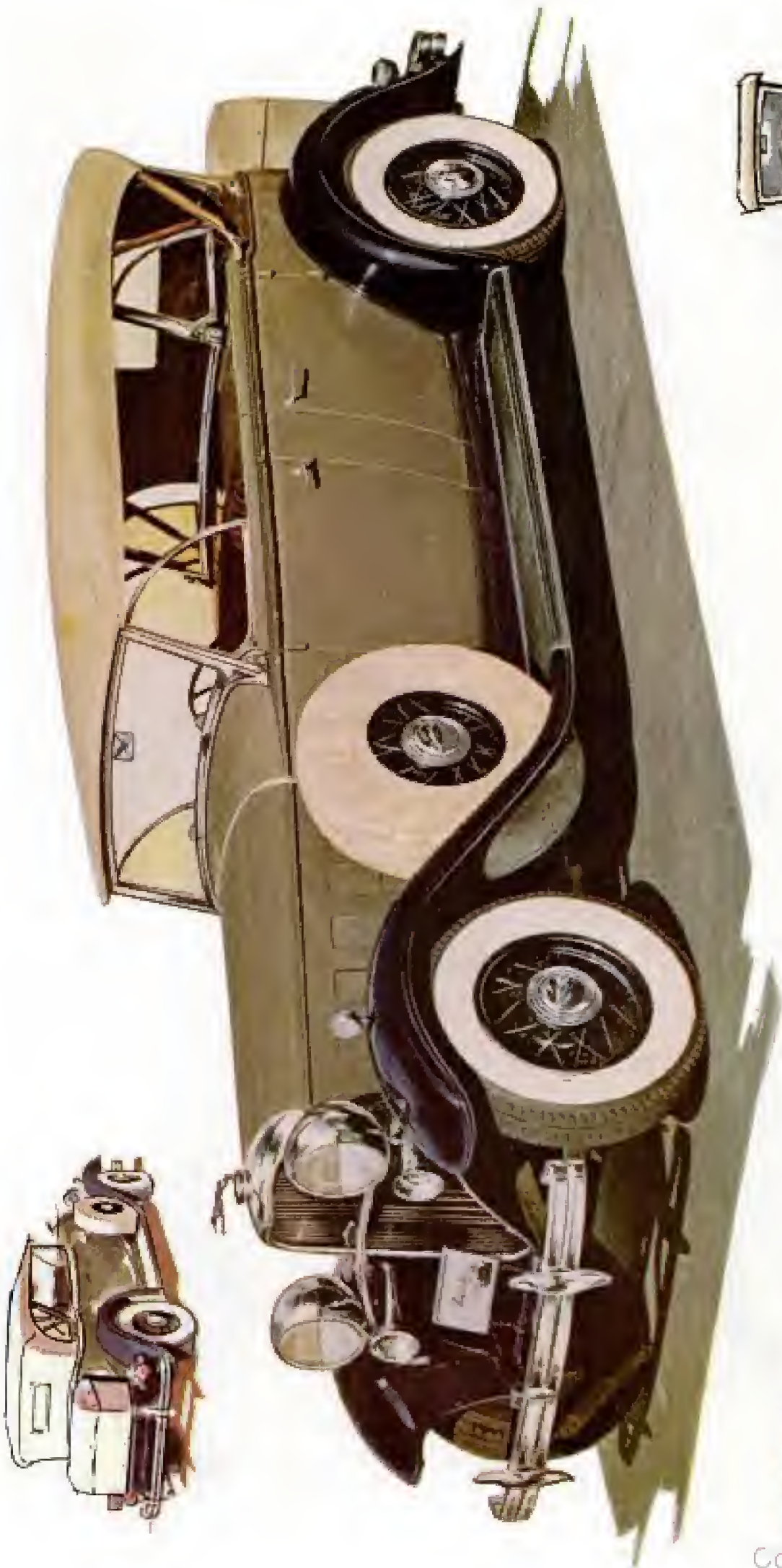

*Lincoln Dual-Cowl Phaeton 1932-KB*

Owner: S. Prestly Blake, Long Meadow, Mass.

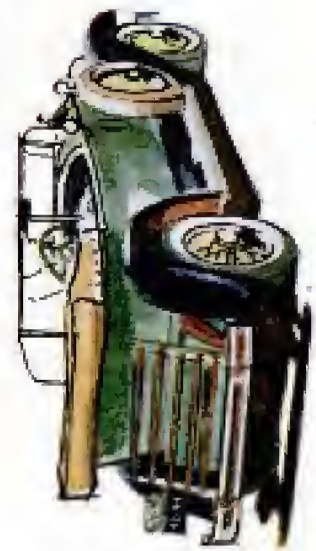
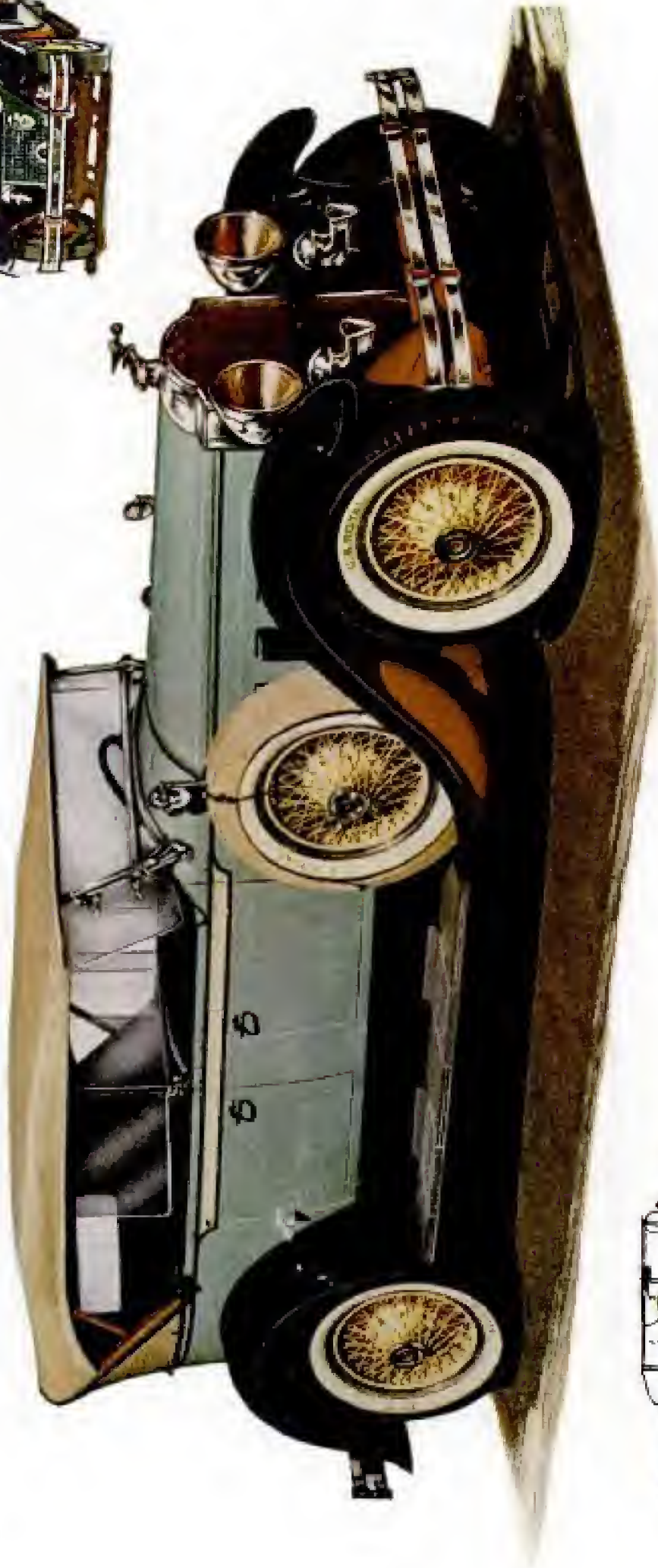
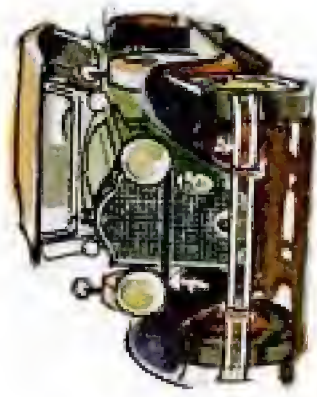

FOURWHEEL

# Packard Sport Phaeton 1929

Owner: J. A. Coletti, Flint, Mich.



**FIFTH:**

*Pierce Silver Arrow  
v12 Sedan 1933*



Owner: Henry Austin Clark, Jr., Glen Cove, N. Y.



**SIXTH:**

*Stutz Super Bearcat 1932*

Owner: Don Jackson, Lindsay, Calif.

149

SEVENTH:

*Cord Convertible Coupe 1937*

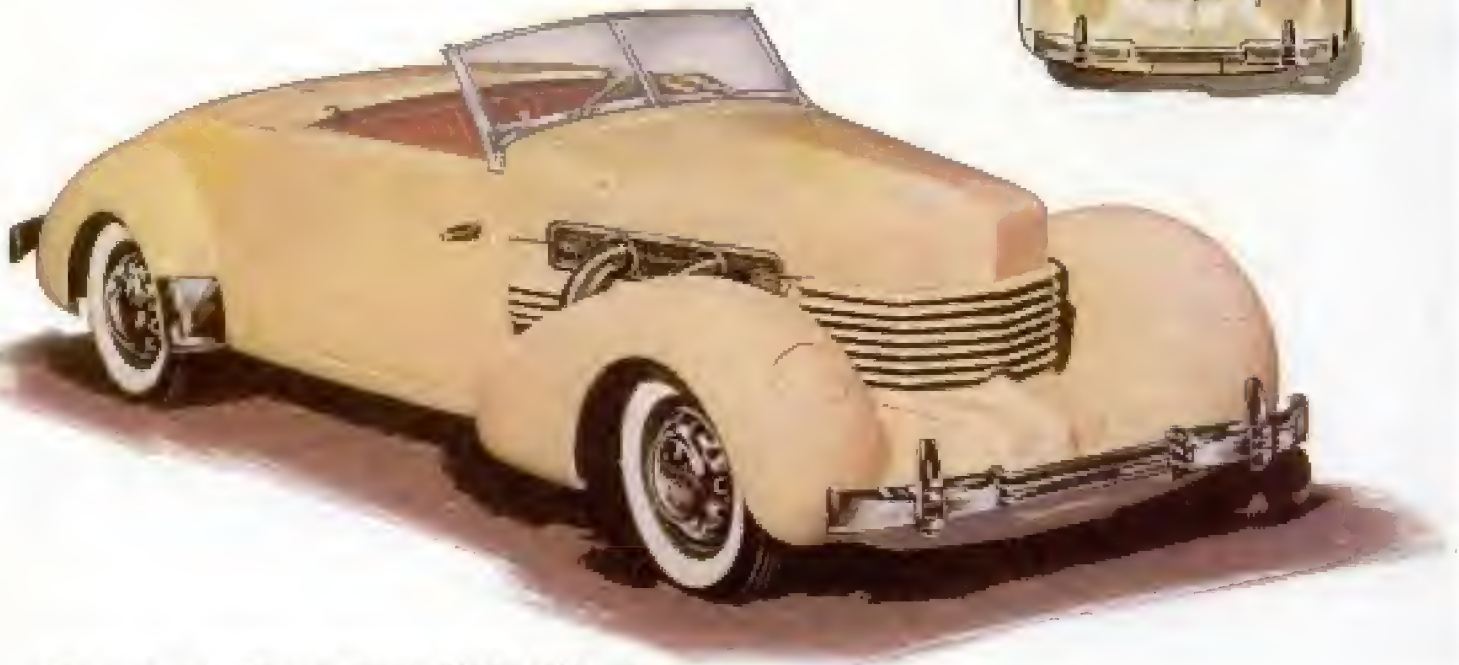

Owner: Dr. Anthony Simone, Philadelphia, Pa.



EIGHTH:

*Packard Speedster 1930*



Owner: George K. Jepsen, Hillsdale, N. J.

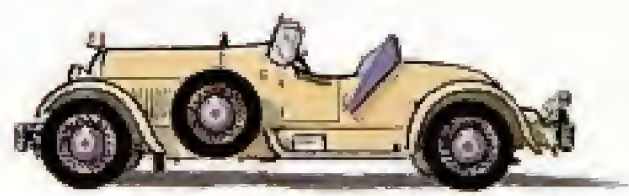

**NINTH:**

*Kissel White Eagle Speedster 1927*

Owner: Sidney Stein, Kew Gardens, N. Y.



**TENTH:**

*Auburn Supercharged  
Speedster 1936*

Owner: Harry Denhard, Greenville, N. Y.





**ELEVENTH:**

*Marmor V16 Club Sedan 1931*

Owner: Arthur G. Rippey, Denver, Colo.



**TWELFTH:**

*Lincoln Continental Convertible 1941*

Owner: Warren A. Custer, Newtown, Pa.

# THE TWELVE BEST *American Classics*

(Continued from page 144)

In the chosen years there are many great cars which might qualify. To choose the Classics among the Classics, the Editors turned to The Classic Car Club of America, whose 700 members devote themselves to preserving and cherishing the hundred and more models they dignify by the name. Officers of the Club accepted our bid for cooperation with enthusiasm. As a preliminary, the Board of Directors of the Club, whose national headquarters are at 122 Cedar Street, New York City, narrowed the field of Classics from scores to 27 American-made cars built in the Classic period. While Classic owners include some famous European makes in their roster—notably the Rolls-Royce, the Bugatti Royale, the Bentley, the Mercedes-Benz and Isotta Fraschini—it was determined that only the American-made Classics would be considered in this special honor roll.

The names of the 27 nominees for fame were submitted by *Popular Mechanics* to the entire membership of The Classic Car Club, whose votes determined the first 12 Classics as shown here. Moreover, their answers to our questions and their wealth of comments attested to their enthusiasm—and to their variety of opinions on what constitutes a Classic.

For the most part they agree that the period from 1925 to 1942 embraced "The Golden Age of Automobiles." As one member wrote, it was the period when custom cars were the "automobilist's ideal, not a sales manager's compromise."

And how, from those 18 model years, do they select the Classic from the less distinguished? The test or definition is almost as varied as the number of members. But, while mechanical qualities are generally mentioned in the comments, it is obvious that body design is the primary concern of the classicists. The ideal, of course, combines both appearance and performance in the highest degree—as embodied, for example, in the magnificent Duesenbergs that won both first and second honors on the list.

Among the standards applied in judging these Classics, in the words written to us by the owners and admirers of the cars, are these:

"It must be clean, pure in line and a work of art to look at."

"It never goes out of style. Its body lines are still beautiful today because of its enduring beauty."

"A classic has body styling of grace and beauty without excessive ornamentation."

"It has dignity, good taste and simplicity. It is restrained with no overplay. It is not high fashion."

All of which is agreeable, but scarcely specific. What is good taste and beauty to one may not please another. Not many agreed on the exact ranking of the first 12 as they appear here; their places result from a cumulative vote. Yet, while styles and designs and mechanics of these top-most Classics differ, they have some characteristics in common. Witness these comments from the Classic owners:

"It must look like an automobile." Unquestionably the winners do. They have graduated from the surrey and sulky stage. They have not yet adopted the lines of the airplane and yacht. Hood, wheels, headlights, doors, taillights are well defined entities.

"A long hood is essential." The select 12 all qualify. From the lean, tense-looking Duesenbergs to the relaxed, luxurious Continental, all have long hoods that cover big engines.

"It is big, racy and expensive." By the dollar standard of their day (or, for that matter, of ours), the leading Classics all meet the test of "big . . . expensive." Finish and materials have improved the luxury of modern automobiles, but the Classic fans will argue that no 1954 automobile can match the 1937 Cord or the 1930 Packard Speedster, for example, in raciness and costly style.

"Tends toward massive style—a luxury car." There is plenty of evidence to support this definition among the 12 winners. The two phaetons, the Lincoln Dual Cowl 1932 and the Packard 1929, are huge. In both of these, the rear seat is a comfortable vastness. You can straighten your legs out and still not touch the front seat. And yet the passenger area occupies only about half the car's over-all length. These cars are truly massive. The Marmon 1931 with its 145-inch wheelbase is another that more than meets this qualification.

"Should have a surplus of power." Generally, the Classics are powerful even by today's standards. The most classic of all, the Duesenbergs, have a straight-8 overhead-valve engine that develops 265 horsepower. The Marmon V16 (yes, that is 16 cylinders) produces 200 horsepower and the Auburn Supercharged Speedster of 1936 develops 150 horsepower.

"The Classic is custom bodied. It is not a stock factory model nor a family car. It has a body built for a particular function."

All the Classics in the select 12 were of

(Continued to page 284)

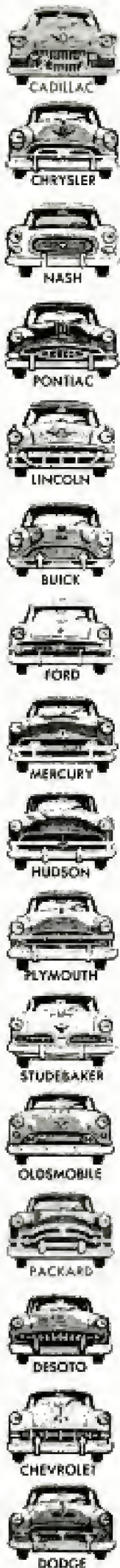

# PARADE OF 1954 CARS

Introduction by Leo Donovan, PM's Automotive Correspondent

## THINGS to remember from 1953:

At long last, the end of the seller's market! At midyear, production was in full swing. Ford made a run for it, producing on a six-day-week schedule with overtime shifts. In some areas Ford began to catch up with Chevrolet sales in September, but the year's total was far below Chevrolet (see chart, page 160).

Competition returned and brought inflated allowances on trade ins and whopping discounts by dealers. The buyer began to get the breaks.

Experimental cars of tomorrow (the so-called dream cars) made their first widespread appearance as manufacturers found a new merchandising technique of introducing in such cars the future styling they couldn't yet incorporate in current models.

General Motors, Chrysler and Ford all came forward with such cars (which, except for the Chevrolet Corvette, you couldn't buy). Hudson joined up with its beautiful Italia. Packard showed the Balboa and Kaiser the DKF plastic convertible.

Mass production of the plastic-bodied Corvette was a milestone in the industry even though the quantity produced was microscopic by industry standards.

The multimillion-dollar fire in GM's Detroit transmission plant in

suburban Livonia, Mich., was the most disastrous in industry history. It completely destroyed the only source of Hydra-Matic transmissions. But GM staged a miracle to get back into mass production in less than three months.

Price cuts began to appear in Kaiser, Chrysler, Dodge, DeSoto and Plymouth and in the fall-introduced 1954 Hudson and Nash lines.

It was the second-highest production year in history, hitting a new high in wholesale value of its products—an estimated \$11,440,000,000. Vehicle registrations soared to 54,-745,000 in the country.

Kaiser-Frazer merged with Willys to become the Kaiser Motors Corp., and moved from Willow Run to Toledo, Ohio.

Garage mechanics, searching for space beneath the hoods of expensive cars with air-conditioning units, wondered how much more complicated their jobs could become. Some forward-looking mechanics began asking how the man in 1960 who buys a 1953 car (then seven years old) will be able to pay him the tremendous labor charges required to work in an engine compartment so cluttered with "extras" that it takes hours of labor just to uncover a cylinder head.

(Continued to page 306)

## PRICE RANGES OF THE NEW AUTOMOBILES

PRICE \$2275 TAKE YOUR CHOICE  
 \$500 \$1000 \$1500 \$2000 \$2500 \$3000 \$3500 \$4000 \$4500 \$5000 \$5500 \$6000 \$6500 \$7000

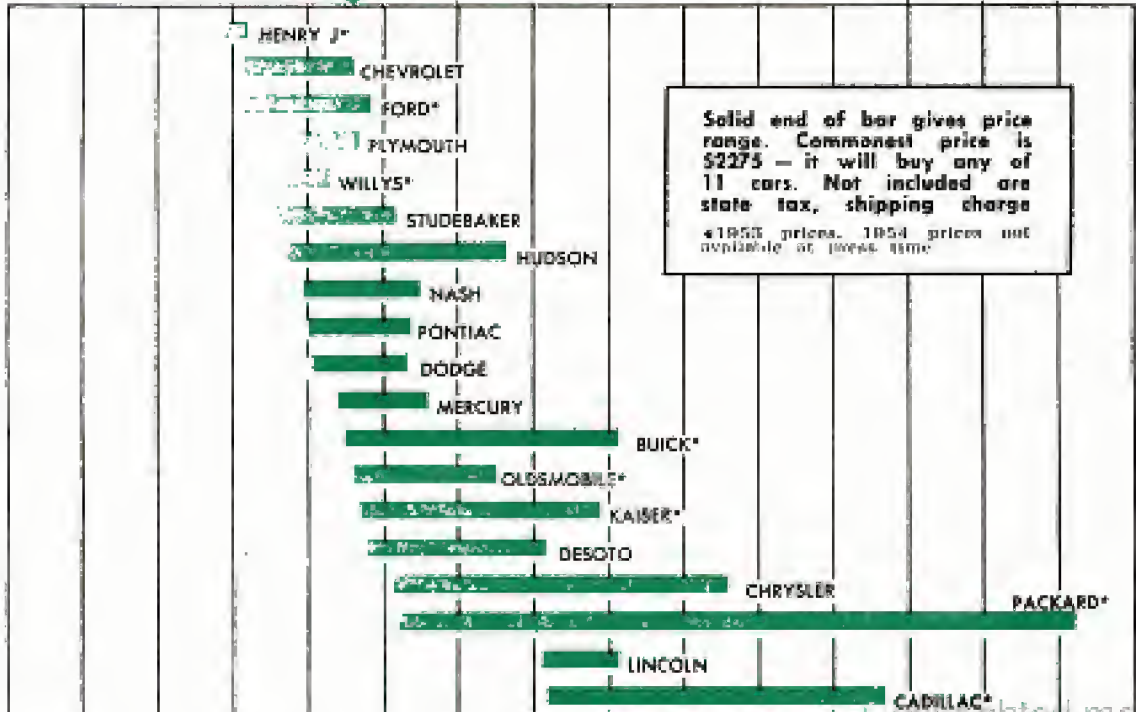



AUTO SECTION



## BUICK

All-new bodies are featured by Buick. Riviera hardtop, above, sports full rear-fender wheel openings. Also new: V8 engine in Special, lower body, finlike rear fender, less chrome, wrap-around windshield.

more horsepower, a Century series combining Roadmaster engine and Special chassis for top performance. Improved power brakes have an electric vacuum pump so you still have power assist when engine fails



## CADILLAC

Cadillac also has a new body. Lower by 1½ inches, longer by 3½, the car has the panoramic windshield, accented but recognizable rear fins; extended head-

lamp visors and a lower hood. Exhaust ports in rear bumper are round. Interior room is greater. Power steering standard on all cars. Horsepower is now 230

Chevrolet has made slight style changes: New tail-lights, headlight rings, parking lights and bumpers. Powerglide transmission is now available on all

models. With it comes a 125-horsepower engine. Handshift cars have 115 horsepower. Power accessories are: Power seat, windows, brakes and steering



## CHEVROLET

Copyrighted material



## CHRYSLER

Body lines are unchanged on the 1954 Chrysler, but under the hood the big V8 engine now has 235 horsepower. Bold horizontal bars give lower appearance to

the car. Changed are grille, headlight trim, taillights and bumpers. PowerFlite automatic transmission has highest torque multiplication ratio in industry



## DESOTO

Style changes, minor though they are, make the '54 DeSoto appear longer. Grille is less emphatic and slants forward, as does the bumper. Horsepower is

now 170 in the V8 with 7.5:1 compression. Interiors are more lush and colorful. PowerFlite transmission is water cooled in the V8 model, air cooled in the six

New is Dodge's Royal V8—a super-de luxe series. All Dodges have greater over-all length, lower and more massive grille and new chrome moldings. Interiors are

new also. Top of dash has textured paint to eliminate sun reflection. Horsepower on the V8 engine is 150, compression ratio 7.5:1. The six develops 110 hp.

## DODGE





Big news at Ford is its new V8 engine (see page 161). Bodies have only slight changes. Extended headlights and redesigned grille are most obvious. Ball-joint

front suspension improves steering and roadability. The '54 Six has a larger bore and horsepower is 115. V8 horsepower is 130. Both have 7.2:1 compression



Rear fenders on the 1954 Hudsons go straight back to triangular taillights. The lower hood has a big, functional air scoop. Front grille is simplified. Most

powerful Hudson is the Twin-H Hornet with its 170 horsepower. The Jet has a new two-door model and all Jets now have an extra two inches rear legroom

Not yet announced, the 1954 Kaiser is expected to have additional horsepower. Basic bodies will be the same, but with new fenders, windows and front grilles. Advance reports also state that the 1954 Henry J will be virtually unchanged

# KAISER

Biggest styling change in Lincoln is a front bumper with three vertical bars that form an air intake. Vacuum-controlled four-barrel carburetor assures ex-

tra power when needed without unnecessary gasoline consumption. Other changes: Magnetic fuel-pump filter, 12-inch brake drums, improved hydraulic tappets





## MERCURY

As with Ford, the big news at Mercury is under the hood—an all-new, overhead-valve V8 (see page 161 for details). It puts out 161 horsepower. Also new

are ball-joint front suspension, a stronger frame and, stylewise, a longer rear fender that extends over the taillight, new front grille and brightwork



## NASH

Continental spare tire is standard on many 1954 Nash models. Style changes are few. The grille is concave. Statesman has dual-carburetor, aluminum head, 110-

horsepower engine with 8.5:1 compression. Ambassador has 130 horsepower (140 optional). Rambler has a four-door sedan on 108-inch wheelbase for first time

## OLDSMOBILE

Another all-new body is Oldsmobile's. Longer and lower, it has little chrome decoration. All fenders are higher, hood flatter; wrap-around windshields on

all models. Engine has more displacement and horsepower is now up to 185. Compression ratio is 8.25:1. Redesigned power brakes retain vacuum if engine dies

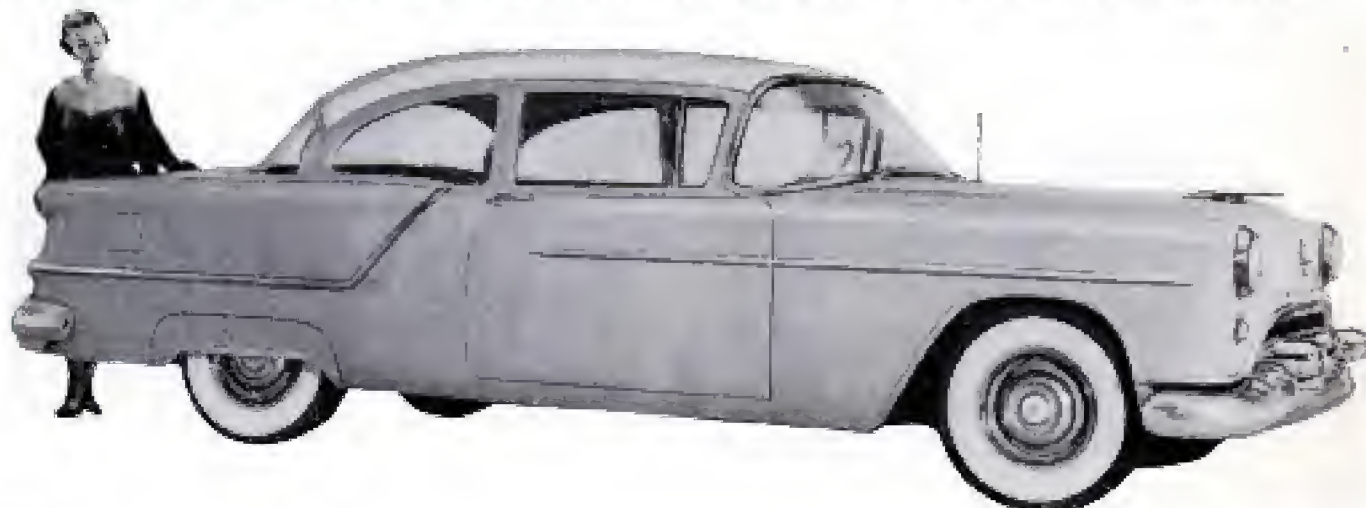



## PACKARD

With new rear fenders that merge into the taillights, the Clipper series gets individual styling to distinguish it from the big Packard. New this year is the

Clipper Panama hardtop. The big Packard straight-eight engine has a nine-main-bearing crankshaft, an 8.7:1 compression ratio and develops 212 horsepower



## PLYMOUTH

Plymouth has new model names this year: Belvedere (the most de luxe), Savoy and Plaza. Basic bodies are unchanged, but extensive trim redesigning makes the

cars look longer and more luxurious. Over-all, they are 3½ inches longer. Grille, headlights and taillights are new. Interiors feature colorful fabrics

Pontiac's grille is oval in design and the chrome stripes on hood are more widely separated. Padded instrument panels and a mechanical four-way front seat are new for '54. Also new is the Star Chief (not

shown) with 127 horsepower, a 124-inch wheelbase and 11 inches more over-all length than other Pontiacs

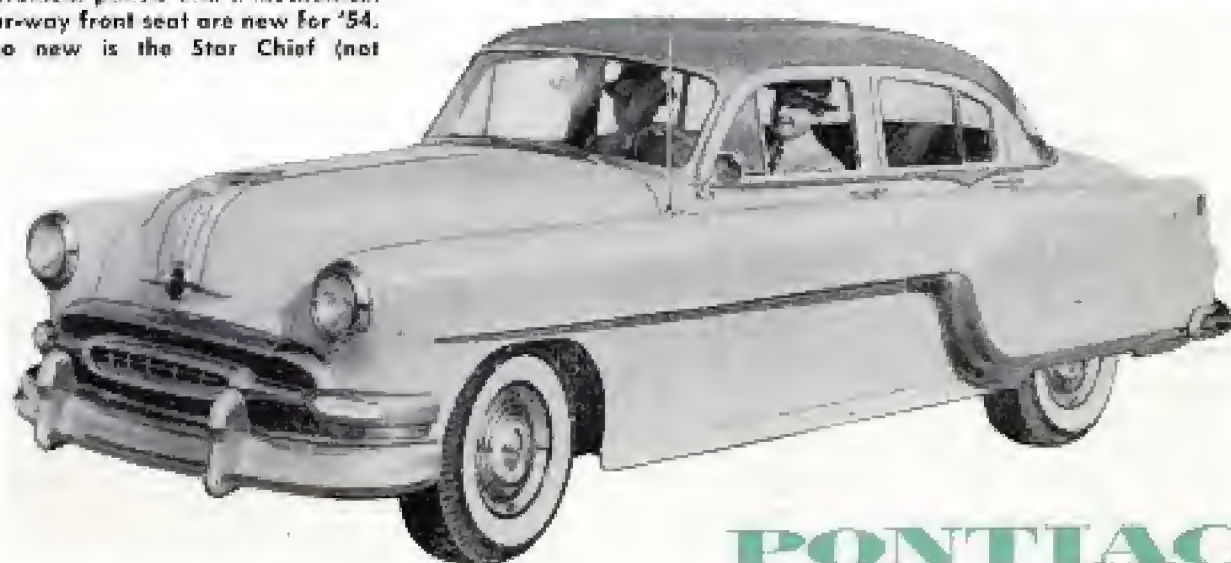

## PONTIAC



## STUDEBAKER

Continuing the sleek design of last year, Studebaker emphasizes colorful interiors, a new grille and bigger bumper guards. Increased compression (7.5:1) on

all models improves performance. Brakes are larger. Low-gear start on Champion's automatic transmission increases pickup. New this year is a station wagon

## WILLEYS

The 1954 models had not been released at press time. Advance information is that there will be important engine changes, but only minor body restyling

### Scoreboard of 1953 Automobile Production

#### THE BIG THREE

GENERAL MOTORS	1,683,362
FORD MOTOR COMPANY	1,479,245
CHRYSLER CORPORATION	1,206,849

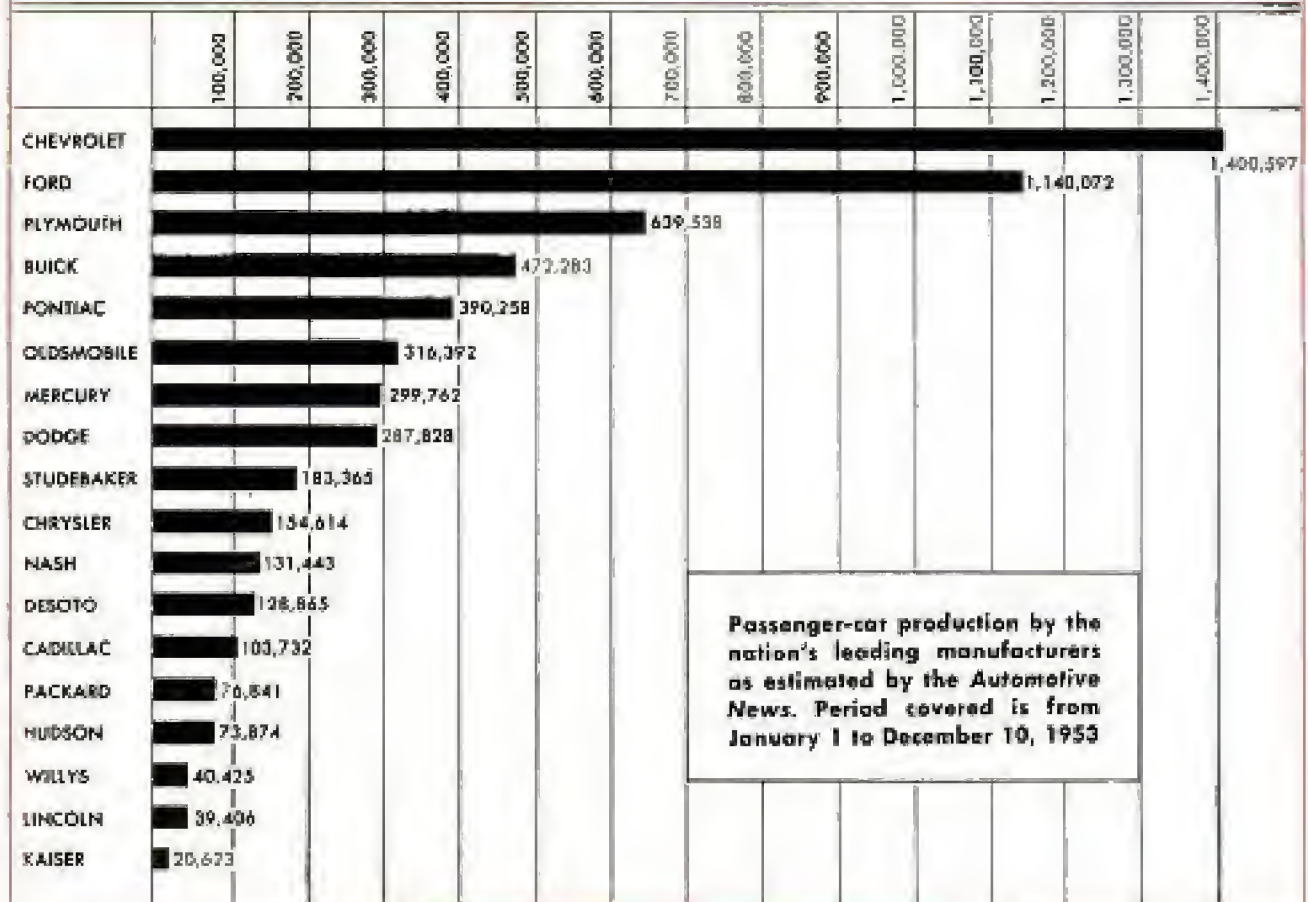

# FORD GETS AN ALL-NEW V8

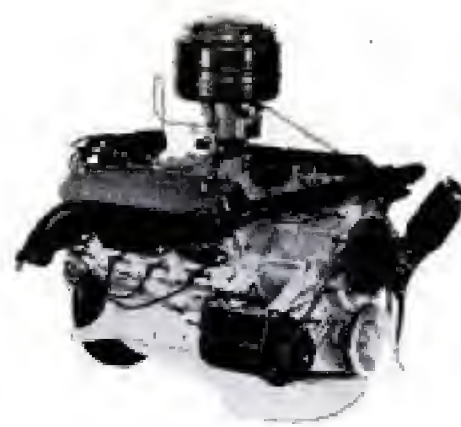

IN 1932 FORD introduced its first V8. Since that time, it has built and sold 16,000,000 such engines—a world's production record. Now, after six years of tests with 640 experimental engines, Ford offers an all-new 130-horsepower V8—the first major change in its basic engine since 1932.

Overhead valves give better breathing. They are free rotating for long life. Rocker arms are short, lightweight



Over-under intake manifold has even-length passages for more even fuel distribution



Crankshaft has five main bearings for greater rigidity. It is 16 pounds lighter than previous design. Block is deep for rigidity



Wedge-shaped combustion chambers give high turbulence. Compression is 7.2:1



## And Mercury Does Too



Mercury has the same basic engine, but gets 161 horsepower by an increased bore for more displacement, a higher compression (7.5:1) and a four-barrel carburetor (above). Only two barrels operate in normal driving. When extra power is required, a vacuum control opens the secondary venturis. Mercury installs chrome-plated top compression rings on its pistons for long wear

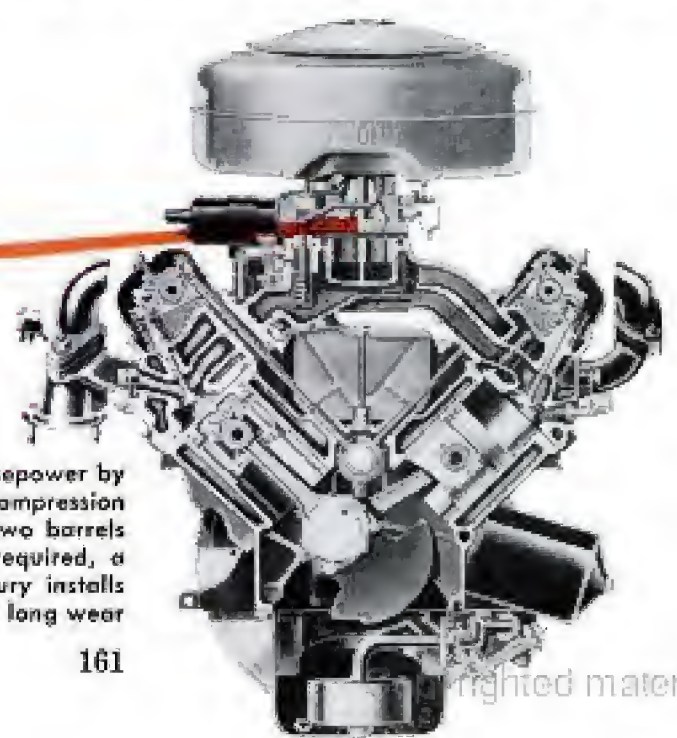

# SPECIFICATIONS OF THE 1954 CARS

## DIMENSIONS

## STEERING

## ENGINE

PRICE 4-DOOR SEDAN	SHIPPING WEIGHT	WHEELBASE	OVER-ALL				FRONT-SEAT HIPROOM	REAR-SEAT HIPROOM	FRONT-SEAT HEIGHT	FRONT LENGROOM	REAR LENGROOM	OVER-ALL RATIO	TURN-CIRCLE DIAMETER	DISPLACEMENT	BRAKE HORSEPOWER AT R.P.M.	BORE AND STROKE	COMPRESSION RATIO	TORQUE RATING AT R.P.M.
			LENGTH	WIDTH	FRONT-SEAT HIPROOM	REAR-SEAT HIPROOM												
\$1680	3210	115.0	196	75	61	13.5	43	41	●	●	23.1	38	235.5	115 at 3700	3.56x3.94	7.5	200 at 2000	
1657	3335	115.0	196	75	61	13.5	43	41	●	●	23.1	38	235.5	125 at 4000	3.56x3.94	7.5	200 at 2000	
N.A.	3155*	115.5	198	74	59	13.0	43	42	●	●	25.3	41	223.0	115 at 3900	3.62x3.60	7.2	193 at 2100	
N.A.	3276*	115.5	198	74	59	13.0	43	42	●	●	25.3	41	239.0	130 at 4200	3.50x3.10	7.2	214 at 2000	
\$1765	3036	114.0	194	74	60	14.4	44	44	●	●	21.1	39	217.8	100 at 3600	3.25x4.38	7.1	177 at 1600	
\$1801	2765	114.5	199	70	60	13.0	43	40	●	●	19.0	39	169.6	85 at 4000	3.00x4.00	7.5	138 at 2400	
2179	3105	116.5	199	70	60	13.0	44	40	●	●	20.0	39	232.6	120 at 4000	3.38x3.25	7.5	190 at 2000	
2438	3180	120.5	203	70	60	13.0	43	41	●	●	20.0	41	232.6	120 at 4000	3.38x3.25	7.5	190 at 2000	
\$1850	2675	105.0	181	67	58	13.3	42	40	●	●	20.0	40	202.0	104 at 4000	3.00x4.75	7.5	158 at 1400	
2256	3440	118.9	202	78	64	12.1	43	38	●	●	20.2	41	232.0	126 at 4400	3.56x3.88	7.0	178 at 2400	
2465	3525	119.9	202	78	64	12.1	43	38	●	●	20.2	41	262.0	140 at 4000	3.56x4.38	7.0	214 at 1600	
2768	3620	123.9	209	78	64	12.1	43	38	●	●	25.6	42	308.0	160 at 3800	3.81x4.50	7.5	264 at 1800	
\$1995*	2650	108.0	193	74	60	12.0	44	40	●	●	19.5	42	195.6	90 at 3800	3.13x4.25	7.3	150 at 1600	
2178	3045	114.3	202	78	65	12.3	43	40	●	●	24.0	45	195.6	110 at 4000	3.13x4.25	8.5	155 at 2000	
2595	3430	121.3	209	78	65	12.3	43	40	●	●	25.5	46	252.6	130 at 3700	3.50x4.38	7.6	220 at 1600	
\$2027	3381	122.0	203	77	60	13.9	43	43	●	●	25.1	41	239.2	115 at 3800	3.56x4.00	7.0	193 at 2000	
2102	3456	122.0	203	77	60	13.9	43	43	●	●	25.1	41	268.4	122 at 3800	3.38x3.75	6.8	226 at 2200	
2301	124.0	214	77	60	61	13.9	43	43	●	●	25.1	43	268.4	127 at 3800†	3.38x3.75	7.7†	234 at 2200†	

### CHEVROLET

Hard shift  
Powerglide

### FORD

Six  
V8

### PLYMOUTH

Six

### STUDEBAKER

Champion 6  
Commander V8  
Land Cruiser V8

### HUDSON

Jet 6  
Wasp 6  
Super Wasp 6  
Hornet 6

### NASH

Rambler 6  
Statesman 6  
Anderson 6

### PONTIAC

Chief 6  
Chieftain 8  
Star Chief 8



<b>DODGE</b>																	
Six	\$2024	3235	119.0	206	74	61	61	14.3	44	41	21.1	41	230.2	110 at 3600	3.25x4.63	7.3	190 at 1600
V8	2244	3425	119.0	206	74	61	61	14.3	44	41	22.2	41	241.3	150 at 4400	3.44x3.25	7.5	222 at 2400
<b>MERCURY</b>																	
V8	\$2251	3450	118.0	206	74	59	59	13.0	43	42	25.4	41	256.0	161 at 4400	3.62x3.10	7.5	238 at 2500
<b>BUICK</b>																	
Special V8	N.A.	3714†	122.0	206	77	62	63	12.8	43	42	26.7	41	264.0	143 at 4200	3.63x3.20	7.2	228 at 2400
Century V8	N.A.	3786‡	122.0	206	77	62	63	12.8	43	41	26.7	41	322.0	195 at 4100	4.00x3.20	8.0	302 at 2400
Super V8	N.A.	4020‡	127.0	217	80	65	66	13.5	43	44	26.7	43	322.0	177 at 4100	4.00x3.20	8.0	295 at 2400
Roadmaster V8	N.A.	4212‡	127.0	217	80	65	66	13.5	44	44	24.14	43	322.0	200 at 4100	4.00x3.20	8.5	309 at 2400
<b>OLDSMOBILE</b>																	
88 V8	N.A.	3692‡	122.0	205	78	62	62	13.2	43	44	27.5	43	324.0	170 at 4000	3.88x3.44	8.3	300 at 2000
Super 88 V8	N.A.	3734‡	122.0	205	78	62	62	13.2	43	44	27.5	43	324.0	185 at 4000	3.88x3.44	8.3	300 at 2000
98 V8	N.A.	3846‡	126.0	214	78	62	62	13.1	43	44	27.5	43	324.0	185 at 4000	3.88x3.44	8.3	300 at 2000
<b>DESOTO</b>																	
Six	\$2385	3590	125.5	215	78	62	60	14.9	44	42	23.0	42	250.6	116 at 3600	3.44x4.50	7.0	208 at 1600
V8	2673	3750	125.5	215	78	62	60	14.9	44	42	25.8	42	276.1	170 at 4400	3.63x3.34	7.5	255 at 2400
<b>CHRYSLER</b>																	
Windsor 6	\$2562	3685	125.5	216	78	62	60	14.6	44	42	25.8	42	265.0	119 at 3600	3.44x4.75	7.0	218 at 1600
New Yorker V8	3228	3955	125.5	216	78	62	60	14.6	44	42	25.8	42	331.1	195 at 4400	3.81x3.63	7.5	320 at 2000
New Yorker Deluxe V8	3433	4060	125.5	216	78	62	60	14.6	44	42	25.8	42	331.1	235 at 4400	3.81x3.63	7.5	330 at 2600
Custom Imperial V8	4259	4345	133.5	224	78	60	60	14.3	45	46	25.8	N.A.	331.1	235 at 4400	3.81x3.63	7.5	330 at 2600
<b>PACKARD</b>																	
Clipper Deluxe 8	N.A.	N.A.	122.0	215	78	63	62	14.0	44	44	27.3	43	327.0	165 at 3600	3.50x4.25	8.0	295 at 2200
Cavalier 8	N.A.	N.A.	127.0	216	78	63	62	14.0	44	48	30.9	45	327.0	185 at 4000	3.50x4.25	8.0	310 at 2200
Patricien 8	N.A.	N.A.	127.0	216	78	63	62	14.0	44	48	30.9	45	359.0	212 at 4000	3.56x4.50	8.7	330 at 2200
<b>LINCOLN</b>																	
Cosmopolitan V8	\$3522	4135	123.0	215	77	62	62	13.5	44	43	26.1	46	317.0	205 at 4200	3.80x3.50	8.0	305 at 2600
<b>CADILLAC</b>																	
Series 62 V8	N.A.	N.A.	129.0	216	80	64	65	14.8	43	46	21.54	47‡	331.0	230 at 4400	3.81x3.63	8.3	332 at 2800
Series 60 V8	N.A.	N.A.	133.0	227	80	64	65	14.8	43	46	21.54	49‡	331.0	230 at 4400	3.81x3.63	8.3	332 at 2800
Series 75 V8	N.A.	N.A.	150.0	237	80	64	69	14.6	43	N.A.	21.54	54‡	331.0	230 at 4400	3.81x3.63	8.3	332 at 2800

■ Dimensions in this column rounded out to nearest whole number. ■ See diagram at right.

N.A. Not available at press time. \* Approximate. † Price in-

cludes radio, heater and cigar lighter. ‡ Hydraulic models only.

‡ Estimated. † Power steering standard equipment.

Specifications are for four-door sedans. Measurements are in inches except: Weight (pounds);

tire-die diameter (feet); torque (pound feet). Prices are for lowest-price four-door sedan in

each series and include all charges except shipping, state and local taxes, and optional

equipment. Specifications of 1954 Willys, Henry J and Kaiser not available at press time.



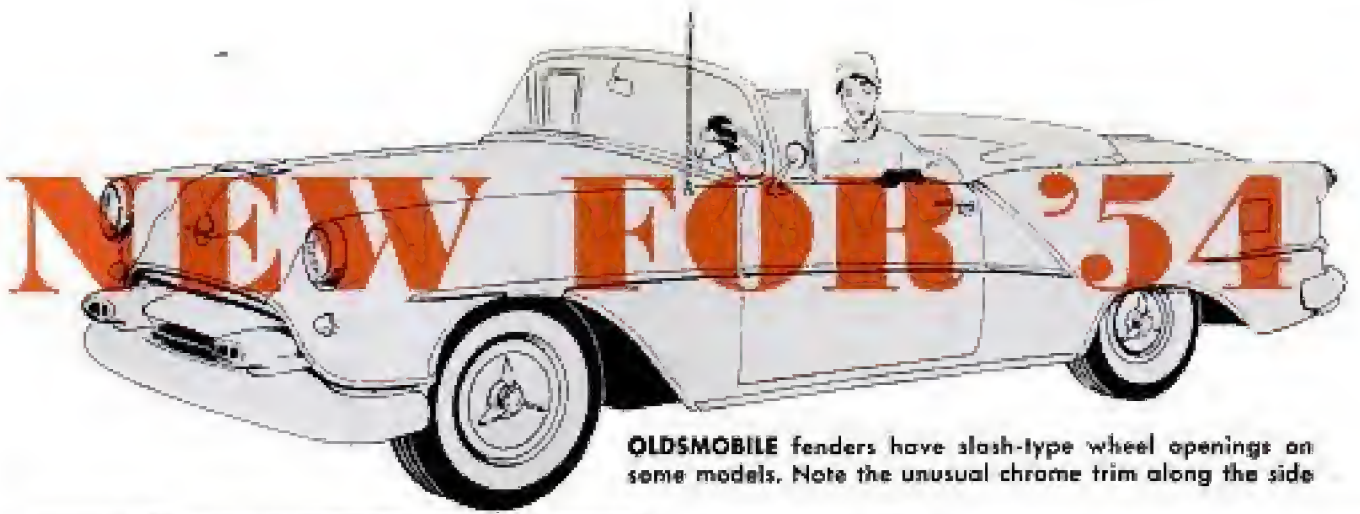

**OLDSMOBILE** fenders have slash-type wheel openings on some models. Note the unusual chrome trim along the side



**MERCURY** has a hardtop with a transparent-plastic roof section. The Ford Skyliner has the same feature



**STUDEBAKER** added vertical bars to its grille, bumper guards and hood ornament are bigger this year

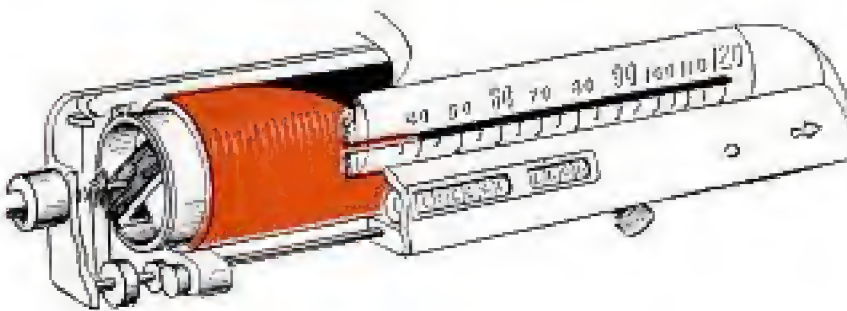

**BUICK** Roadmaster speedometer reads like a thermometer. Cutaway shows red advancing as drum turns

**NASH** Rambler has a four-door sedan for first time. Its front seat swings down to make a comfortable bed

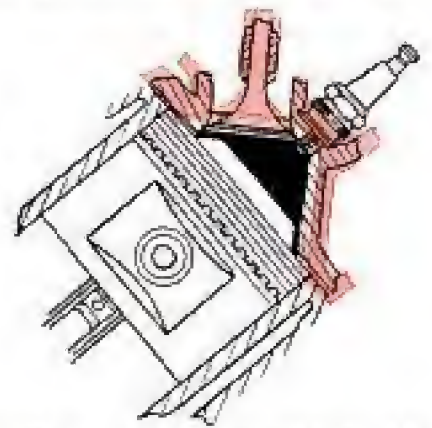

**BUICK** also redesigned its combustion chamber to add power. Red sketch shows 1953 design for comparison

**CADILLAC** has enlarged the "eyelid" over its headlight, forming it with the top part of the fender





**DESOTO** has an instrument panel made up of perfect circles. Each instrument has a separate dial face for maximum clarity and visibility



**MERCURY** extended its rear fenders over the top of the taillight unit



**LINCOLN** increased brake-drum diameter to 12 inches (1953's was 11), reducing braking effort 25 percent



**HUDSON** Jet has a removable rear seat. With it out, trunk divider wall drops to make huge loading area

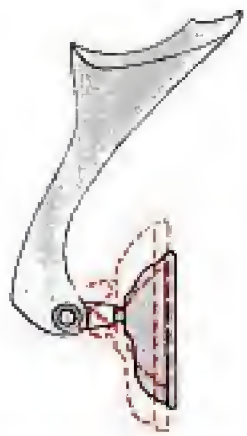

**PLYMOUTH's** rear-view mirror adjusts vertically

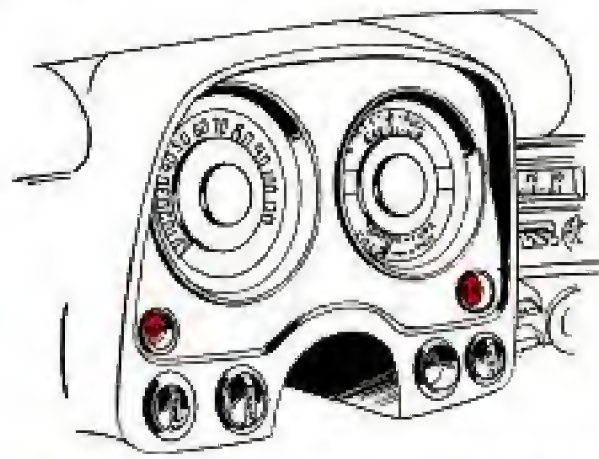

**CHRYSLER** also has a new instrument panel. Indicator lights (red) show oil pressure, amperage



**CHEVROLET's** new 125-hp. engine has high-lift cams

**PACKARD** Clipper introduces a new rear-fender styling with taillights that jut sharply rearward

**CHEVROLET** headlights have a novel chrome ring. The oblong parking light is on outer edge of grille



# NEW FOR '54

SEAT TILTED FORWARD



SEAT TILTED BACK



SEAT RAISED

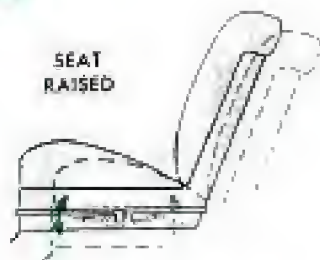

PONTIAC drivers can adjust their seat up or down, tilt it forward or backward. It is manual, not motorized



CADILLAC has a narrow chrome visor over its wrap-around windshield below which is the heater intake



FORD has a raised speedometer with a plastic top through which daylight enters to brighten numerals

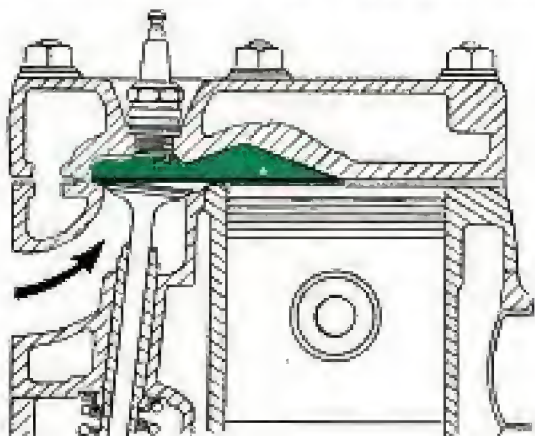

PACKARD redesigned the combustion chamber in its big straight 8 to boost its output to 212 horsepower

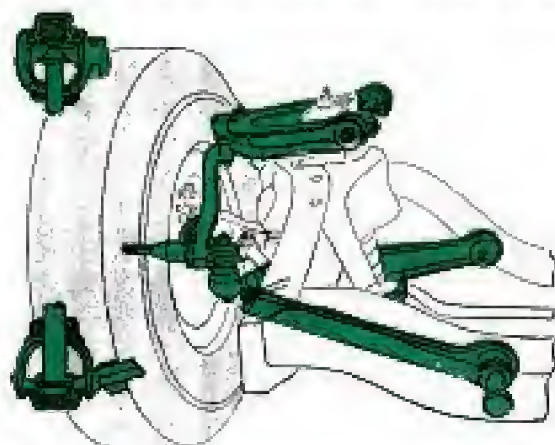

FORD has ball-joint front suspension which eliminates conventional kingpin, improves ride and steering

MERCURY retained the lever-type heater controls in its new dash that has more instrument visibility



PLYMOUTH's low-priced Plaza has a handsome two-spoke wheel. All models have nonreflecting dash panel



**BUICK** front corner pillars are vertical (left) on Super and Roadmaster, slanted on Special and Century

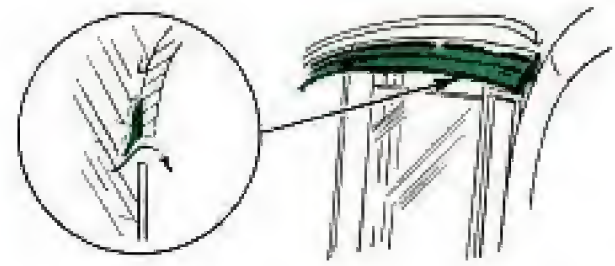

**BUICK** has a wide chrome molding above doors. It serves as an awning and keeps rain out of windows



**HUDSON** lowered its hood and added a broad air scoop that admits air into top of engine compartment

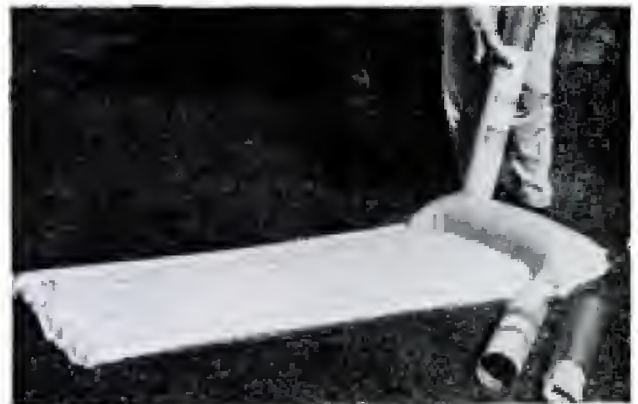

**NASH** owners can buy a mattress for car bed. Cardboard container becomes a pump to inflate it easily

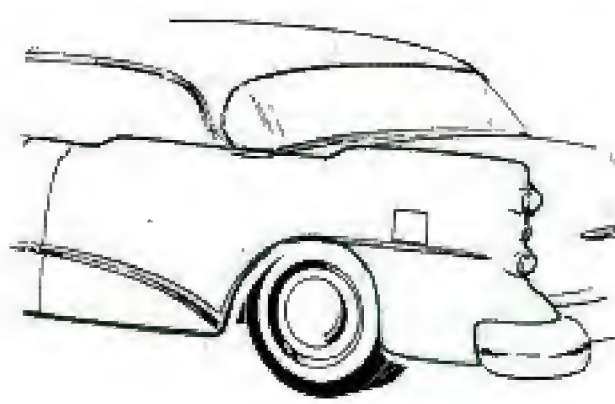

**BUICK** has a double "kick up" on its rear fenders. On hardtop models the wheels are entirely uncovered

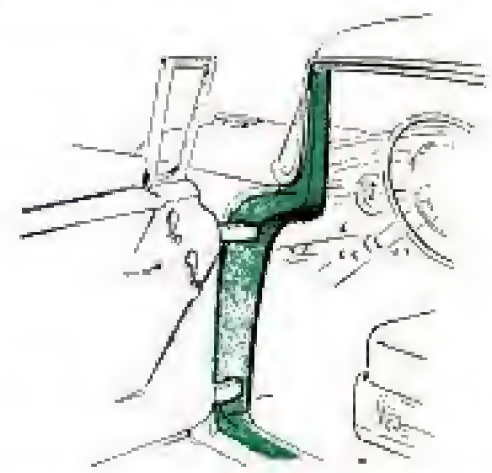

**OLDSMOBILE** doors have "notched" leading edge that increases opening size, making it easier to get in

**HUDSON** lengthened its rear fenders and put tail-lights in them. Backup lights are just above bumper

**DODGE** clipped the horns of its ram hood ornament to make it streamlined. Trim on head vent is larger



**STYLING**

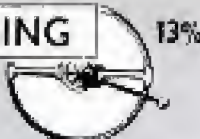

13%



49%

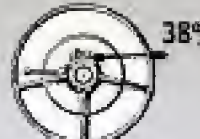

38%

**STEERING WHEELS:** The horn ring seems here to stay with only 13% of the owners not wanting any at all



51%



24%



25%

**WHEEL OPENINGS:** It is surprising to note that so many owners would like full openings in front and rear



27%



59%



14%

**HOOD ORNAMENTS:** The ornate swan appealed to very few; less than one percent wanted no ornament at all

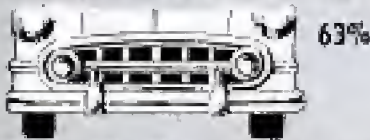

63%



21%



16%

**FRONT GRILLES:** Surprising result here was that the most ornate grille was the least popular with owners



8%



24%



68%

**DOOR HANDLES:** There's no doubt about the popularity of the push button; the turn handle seems to be out



38%



44%



18%

**OVER-ALL SILHOUETTES:** Owners still prefer the squared-box outline to the sleeker "continental" look



25%

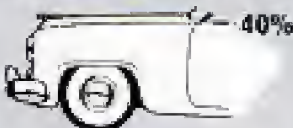

13%

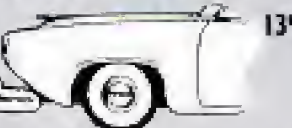

62%

**FRONT-FENDERS:** The extended front headlight, common on 1954 cars, is favored by owners, the poll shows



47%

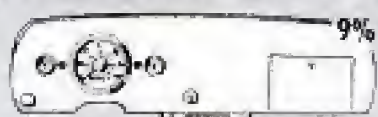

9%



44%

**DASHBOARDS:** Few owners want the simple, uncluttered dash; a large number want it loaded with everything



13%



23%

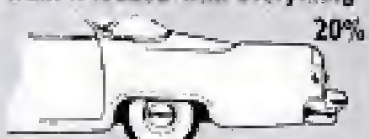

20%

**REAR FENDERS:** The upturned "fishtail" doesn't seem to be as popular as a simpler design, the poll shows



13%



34%



53%

**CHROME:** Owners are definite about chrome; many don't like it at all, most want it used with moderation



Owners Turn Designers in This

# REPORT TO DETROIT

A Nationwide Survey of What Car Owners Want

**L**ISTEN, DETROIT, the public is talking about your product—the American automobile. This article was written by the men and women who own and drive automobiles—all makes and styles of automobiles.

Popular Mechanics asked 5000 owners what they think about the cars Detroit is building. Their responses brought out some amazing points.

Apparently, the manufacturers and the owners don't agree on some important matters. For example, the owners don't want more horsepower! Yet there is hardly a 1954 model on display today that isn't bragging about its increased power.

The survey shows that 70 percent of the owners were emphatically against continuing "the trend toward greater horse-

*Is Detroit making the kind of automobile the public wants? To find out, Popular Mechanics asked 5000 owners of all makes what they want in a car. This is their reply.*

*By Floyd Clymer*

power." Only 19 percent—less than one in five—approved of the trend. The other 11 percent were noncommittal.

"I believe they have gone too far overboard with this horsepower race. Cars are too powerful to be safe these days."  
—Jonesboro, Ark., coach.

"I do not agree with the race for more horsepower. The human element in drivers certainly cannot safely handle the speed which the high horsepower produces."  
—Portland, Ore., engineer.

"Pure nonsense. If a person wants horsepower he should drive a truck. Performance, in my estimation, does not depend upon horsepower."  
—Casper, Wyo., oil worker.

"It's suicidal. We are all too brave behind the wheel."  
—Barrington, Ill., advertising director.

Here is the composite automobile that American motorists "designed" for themselves—its body features combined by our artist from the choices marked on the style ballots (opposite page) sent to 5000 car owners

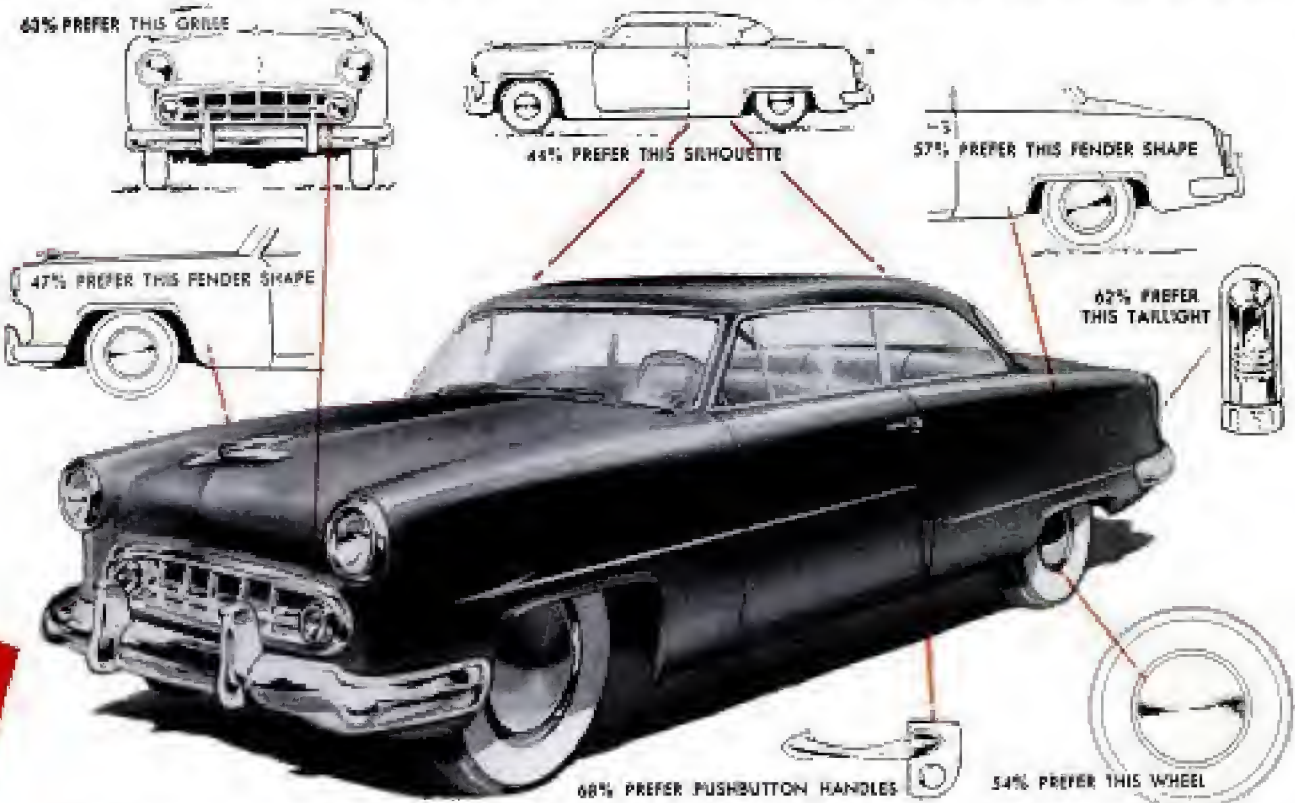

## WHO IS THE AVERAGE OWNER?

He drives 15,480 miles a year, takes four long trips averaging 1200 miles each. His car is fully loaded only 20% of the time.

He buys a new car every three years. The most frequently given reason for trading is the mechanical condition of his old car. Only 1 owner in 10 trades because his old car is "out of style."

He would like the car manufacturers to stop the horsepower race and to put additional emphasis on building safety into his car

## WHAT DOES HE WANT IN A NEW CAR?

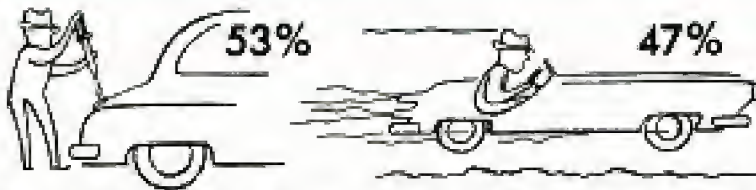

53% say economy of operation is more important than power and performance, but 47% put performance first in selecting a car

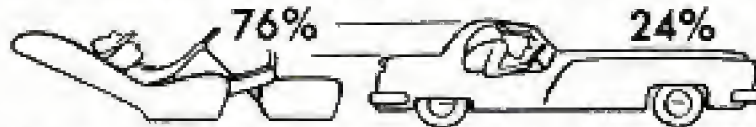

76% want comfort first, styling second. Only 24% are willing to sacrifice comfort for style or appearance, the poll shows



Would the average owner buy a basic car (one without frills or luxuries) for \$1000? 44% said they would not. 36% would buy it as a "second" car. Only 20% would buy it for use as a family car

## WHAT WOULD HE LIKE IN AN ENGINE?

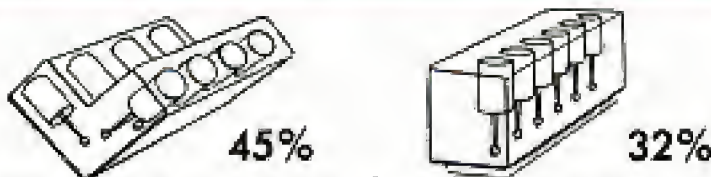

Preferences in engines: 45% want a V8; 32% want a straight 6; 13% want a straight 8; 8% want a V6; and 2% want 4 cylinders

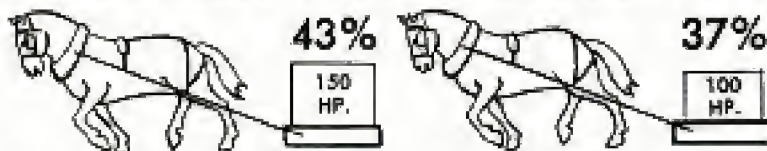

Preferences in horsepower: 43% want 150; 37% want 100; 12% want 200; 4% want only 60; and there are 4% who want over 200

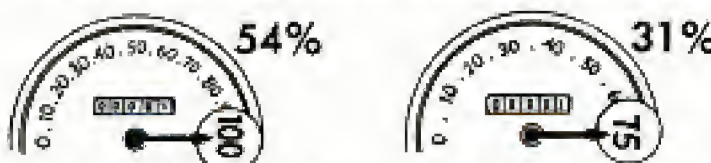

Top speeds: 54% want 100; 31% want 75; 13% want 125; 2%, 60

"Asinine. Greater horsepower serves only to tempt fools to step on it."—Lewiston, Idaho, employment manager.

There were many, many equally emphatic statements that Detroit has gone far enough in the horsepower race and should be doing more about safety. That feeling among car owners was apparent from the responses to the question: "If you could make one suggestion (disregarding price cuts) to the men who design and build American automobiles, what would it be?"

By a wide margin the most frequently given suggestion asked for more safety rather than more power. In fact, a number of owners even asked that maximum-speed controls be built into the cars at the factory to protect themselves against their own bad driving habits. Here are some of the changes the owners want: Stronger roof structure, including roll-over bars; lower horsepower; governors or some type of speed control; better brakes and vision; and better handling and roadability.

There is no doubt that if owners have to choose between speed and safety, they will take safety—that is the most emphatic finding in our nationwide survey.

And yet when it comes to seat belts, the owners seem to take a different viewpoint. Only 14 percent of the owners said they would wear seat belts at all times if such belts were provided as original equipment in their cars. A surprising 45 percent said they wouldn't wear the belts at all, even if car manufacturers provided them. The other 41 percent said they would wear them during high-speed driving only.

There are points where the owners agree wholeheartedly with Detroit, and current body styling is one of them. A high 69 percent are pleased with the trends in styling today, while only 16 percent disapprove. The others made no statement for or against.

As the percentages on the styling ballot (reproduced on page 168) show, generally, the owners prefer the middle-of-the-road design. No extreme or radical innovations for them. The com-



posite car (page 169), based on the owners' selections, is certainly not revolutionary in styling. Its basic shape is similar to that of millions of cars on the road today. Apparently Detroit is providing the public with what it wants in the styling department, although there are a few interesting upsets as will be noted in the percentages.

The majority also likes the trend toward power accessories. More than half, 53 percent to be exact, said one or more of the power accessories, such as brakes, steering, seats and windows, was worth its cost. Disagreeing were 29 percent, with 18 percent registering no opinion.

"Power steering and power brakes should be standard equipment." — Klamath Falls, Ore., school supervisor.

"Power accessories mean greater safety and convenience for feminine drivers." — Poughkeepsie, N. Y., engineer.

"For town driving, power steering is all right. I don't like it on the open road." — Springfield, Mo., policeman.

"Power steering is especially bad if used to cover up or camouflage defects in weight distribution or faulty steering-gear geometry." — Cedar Grove, N. J., engineer.

"I do not approve of power steering. A sudden swerve may cause the car to turn over." — writes an Alton, Ill., service-station operator.

"If they keep up with these power accessories the fun of driving will be gone." — North Stratford, N. H., mill worker.

It looks as though Detroit is right in assuming that America has outgrown the "basic transportation" market. Despite the oft-heard remark that what this country needs is a \$1000 automobile, only 20 percent of the owners said they would buy a \$1000 vehicle as their family car, if it was a basic car without luxuries or conveniences. Another 36 percent, however, would be interested in it as a second car. The remaining 44 percent would not buy it at all, apparently preferring to spend more for the luxury and comfort to which we

(Continued to page 294)

## WHAT ELSE DOES HE WANT?

How many seats?

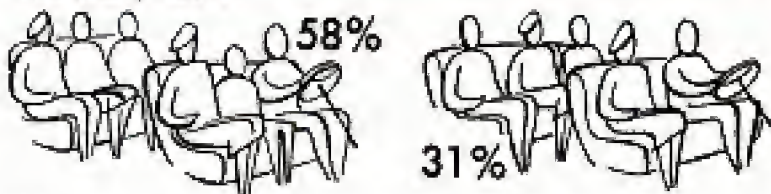

58% want 6 seats; 31% want 5; 6% want 4; 3% want 8; 2%, 3

How long a wheelbase?



115 and 125 inch are most popular; 6% want 130; 5% want 100

Would he wear a seat belt?



45% would not; 14% would all the time; 41% would at high speeds

More durable upholstery? Or seat covers?

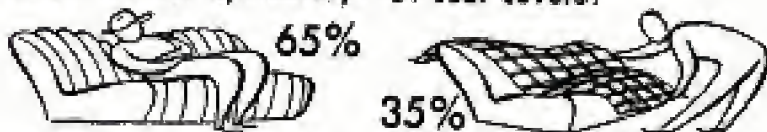

65% would pay extra for plastic or leather; 35% prefer seat covers

What accessories does he want?

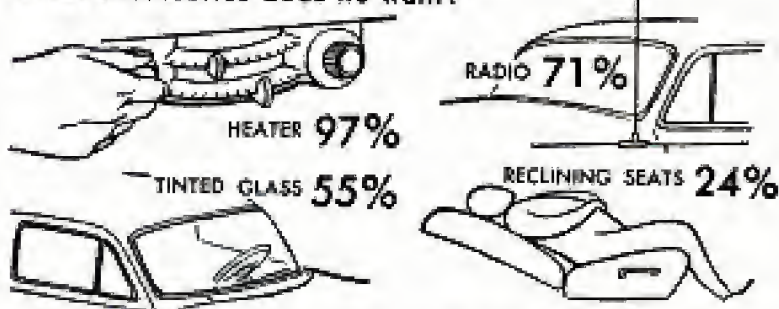

Also: Automatic shift 50%; power brakes 33%; power steering 22%; headlight dimmer 14%; air conditioner 6%; and power windows 5%

## WHAT DOES HE WANT IN THE FUTURE?

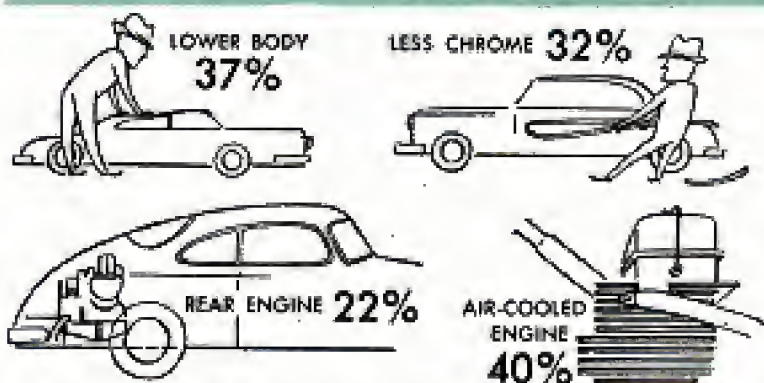

Other changes: 16% of owners want shorter bodies; 9% want front-wheel drive; 12% want longer bodies; 9% want more chrome



**AUSTIN** offers a new two-door sedan, left. It is just over 11 feet long, four feet less than the shortest U.S. car, and is built for economy. Its engine is an overhead-valve four

**FORD** introduces a new Anglia in England for '54, below. It has 4 cylinders, unitized body, gas tank in rear fender



**STANDARD'S** new economy model is a four seater, above. It has a large trunk accessible from the rear seat. It too has four cylinders

## A TRANS-ATLANTIC VIEW OF EUROPE'S 1954 MODELS

**HANSA DIESEL** is German. Its four-cylinder engine goes about 40 miles per gallon of diesel oil. Swing axles are used in rear



**LAGONDA**, below, is among the world's most advanced cars, with independent suspension on four wheels, inboard rear brake drums, built-in jacks and an entirely flat floor. It has six cylinders



**RILEY** Pathfinder, below, seats six, has four cylinders, two camshafts, hemispherical combustion chambers, a torsion-bar front-suspension system



**ALVIS** Grey Lady, left, is a 100-mile-per-hour sedan with a high-compression, overhead-valve "square" engine and a seven-bearing crankshaft

**DAIMLER** Conquest roadster, right, has aluminum-alloy frame and body. Other features include twin carburetors, air scoops in front and rear fenders to keep the brakes cool, and torsion-bar front-wheel suspension

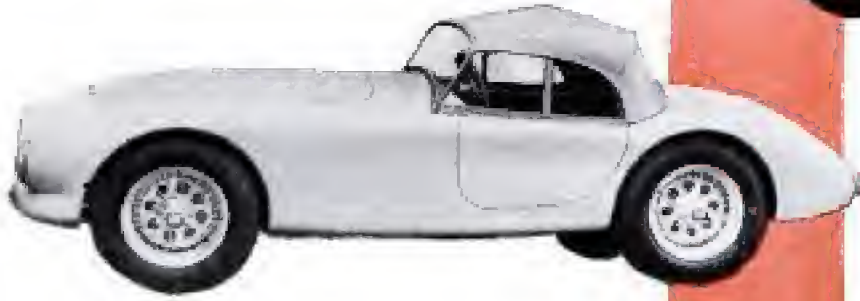

**A.C. ACE**, left, is a speedy two-seater that easily hits 100 m.p.h. Engine is an overhead-camshaft six with three carburetors. Frame is formed of two straight steel tubes. All wheels are independently sprung

**BRISTOL 404**, right, has carefully designed aerodynamic body shape. Rear springing is by torsion bars, front by leaf springs. Brakes are exceptional with light alloy drums. Car will easily exceed 100 miles per hour



**JOWETT** Jupiter, left, a competition two-seater has four horizontally opposed cylinders, an 8.5:1 compression ratio. Engine fan is driven by thermostat-controlled electric motor for perfect cooling at every speed

**ASTON MARTIN** DB2-4, right, is a fast, 110-mile-per-hour touring car. Its inline six has twin overhead camshafts, inclined valves, hemispherical combustion chambers. Rear window opens for access to luggage space



**SINGER** is making a plastic-bodied 4-seater. Luxuriously finished, it is a rich cream plastic. Entire front body section hinges up to uncover the engine

**LANCIA** Gran Turismo, below, has the famous Italian styling and the fine V6 engine that won the 1953 race in Mexico. All wheels are independently sprung. Clutch, gearbox, differential are a rear-mounted unit



# What Makes Your Car Run?

## ITS POWER PLANT

**Y**OUR CAR is driven by a series of explosions. The more powerful the explosions and the closer together they occur, the faster your car can go and the better its acceleration. The smaller these explosions and the less frequently they occur, the greater your car's economy.

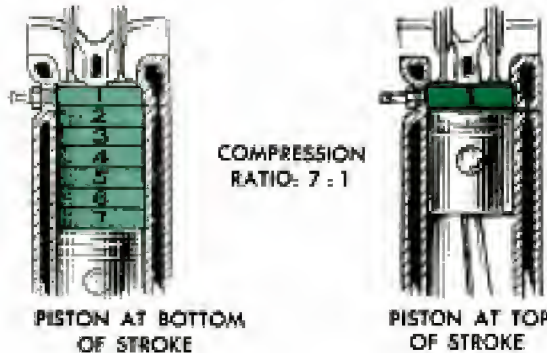

The total number of explosions required to move your car a given distance depends upon its transmission, rear-axle ratio and tire size. The strength of each explosion depends upon engine size and design. Involved are displacement and compression ratio. The higher the compression, the more power a given amount of fuel is able to deliver.

● Compression ratio is the ratio between the volume of the cylinder when the piston is at the bottom of its stroke and the volume when it is at the top. It is the number of times the fuel mixture is compressed before ignition.

Displacement is the difference between these two volumes—or the amount added as the piston moves to the bottom of the cylinder. To get the engine displacement you multiply this amount by the number of cylinders.

● Engines are classified according to cylinder arrangement. Inline engines have their cylinders arranged one behind the other in a row. V-type engines mount the cylinders in two rows, tilted at an angle that forms a vee. Today's trend is definitely toward V engines.

● Engines are also classified by valve position. The L-head engine has both intake and exhaust valves in the block. The overhead-valve engine has both valves in the head above the cylinder. A combination of the two, the F head, has one valve (usually the intake) in the head, the other in the block.

● The function of the engine is to burn a mixture of air and gasoline efficiently. Therefore, an engine must inhale, burn and exhale the mixture many times a minute. This makes engine "breathing" important. Your engine breathes about 9000 times as much air as gasoline. To move such tremendous volumes quickly requires a high volumetric efficiency—the engineer's term for free breathing.

Engine breathing has been improved greatly in recent years. In fact, many recent boosts in horsepower are due almost entirely to this improvement. Intake manifolds are smoother and more direct, speeding the passage of the fuel mixture to each cylinder. Twists and turns in the manifolds have been minimized. Valves are larger, lift higher and stay open longer for the same reason—to get more fuel in and out of the combustion chamber faster.

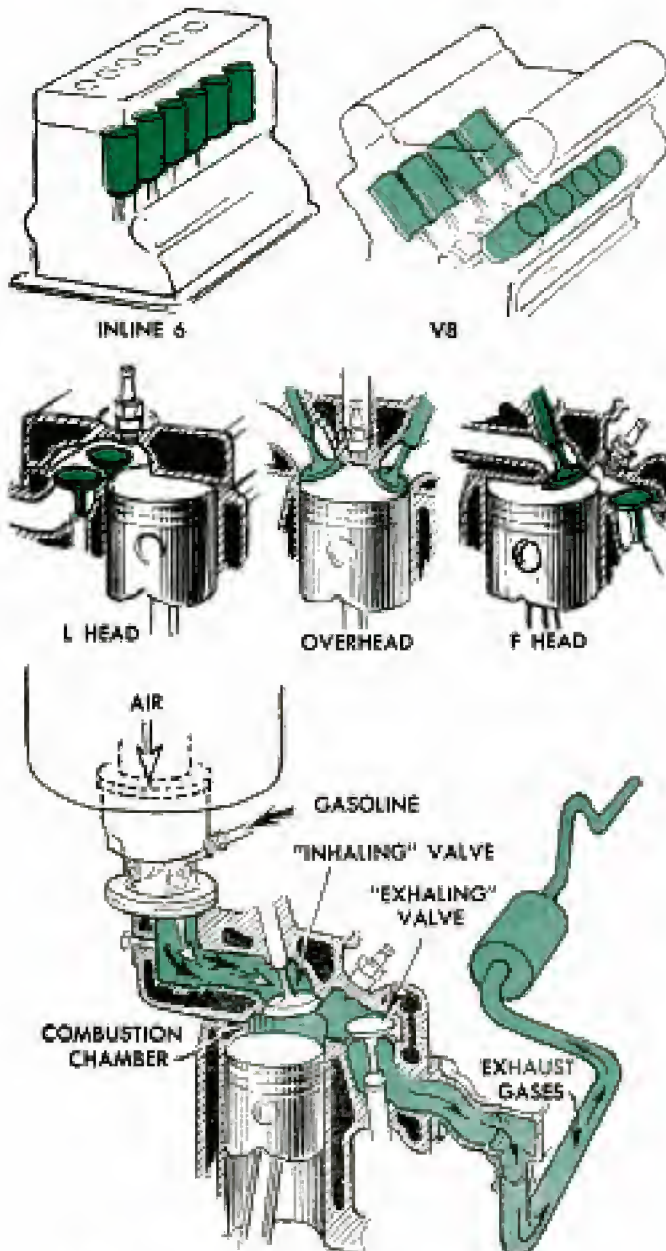

● Overhead valves are being used more frequently because (among other reasons) they open directly above the piston, permitting better breathing. Exhaust manifolds, mufflers and exhaust pipes are less restricted, larger in diameter, to offer little resistance to the flow of the burnt gases. The result is better exhaling.

● Four-barrel carburetors are becoming common on the more powerful engines. The reason: To bring in more fuel mixture when the throttle is wide open, as in acceleration or at high speeds. Only two barrels work most of the time, the other two opening when you call for extra power by flooring the accelerator.

### ITS TRANSMISSION

Although a gasoline engine is powerful, it doesn't produce much power until it is turning over fairly rapidly. It doesn't even have enough power to keep itself running at very low speeds. Beginning drivers often stall the engine when they fail to give it enough throttle to produce sufficient power to start the car moving. To make it possible for the engine to turn over rapidly while the car is just starting to move or is moving slowly or is climbing a hill, a transmission is required. Its function is to provide suitable gear ratios (or leverages) between the engine and rear wheels so the car will operate under all driving conditions.

● The synchromesh transmission is the standard hand-shift unit in use today. It consists of various sized gears on separate shafts. The gears mesh as you move the shift lever. The transmission eliminates any grinding or clashing of gears by synchronizing the speeds of the mating gears before they engage.

● The planetary-gear train is a simpler, more compact and convenient method of changing gear ratios. It has a center or sun gear, planet gears in a carrier and a large ring gear. Used singly, it does not have the range of synchromesh, but in groups of two or three or when coupled with a torque converter, it is excellent. The unit controls torque and speed, reverses direction or acts as a direct-drive coupling. Being always in mesh, it is ideal for automatic transmissions. The planetary is also used in overdrive where it provides gear ratios of less than 1:1, enabling your car to go farther on each engine revolution.

● A fluid coupling consists of two parts called torus members and shaped like a doughnut split sidewise. Each half is attached to a separate shaft and immersed in an oil-filled housing. As one member is rotated by the engine, its vanes force the oil to move, which in turn rotates the other member as wind spins a windmill. Used with a conventional transmission, the fluid coupling serves as a cushioning connector between the automobile's engine and transmission.

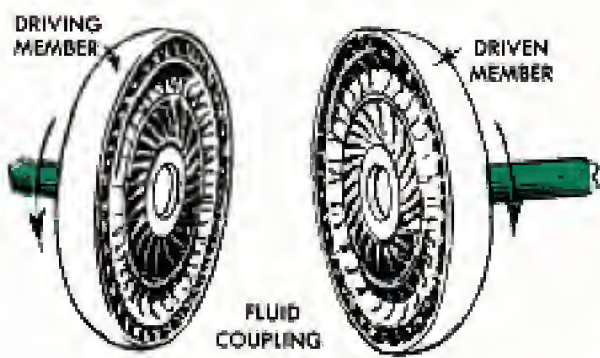
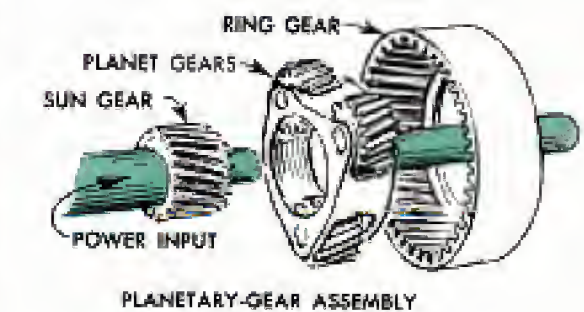
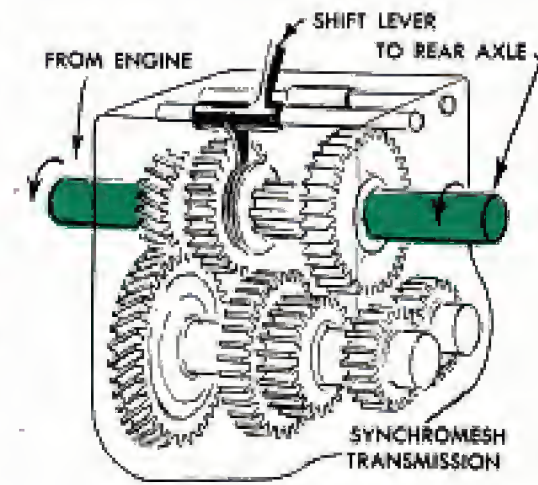
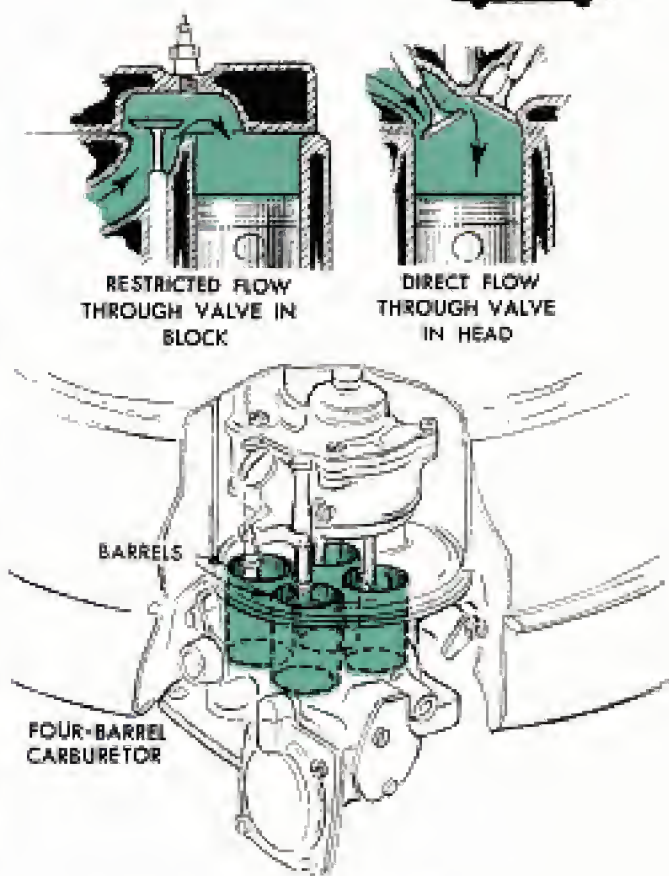

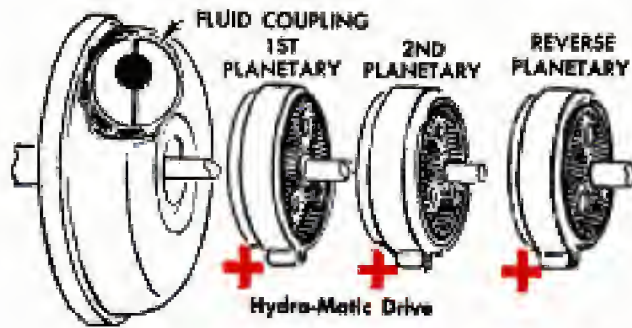

● In Hydra-Matic, an automatic transmission, the fluid coupling is the clutch, permitting the engine to idle while the car is standing still. It has no torque multiplication (or leverage). Two planetary units (plus a third for reverse) provide the multiplication and give four forward speeds. Gear changes are made automatically by a system of brake bands that locks the elements of the planetaries to change ratios.

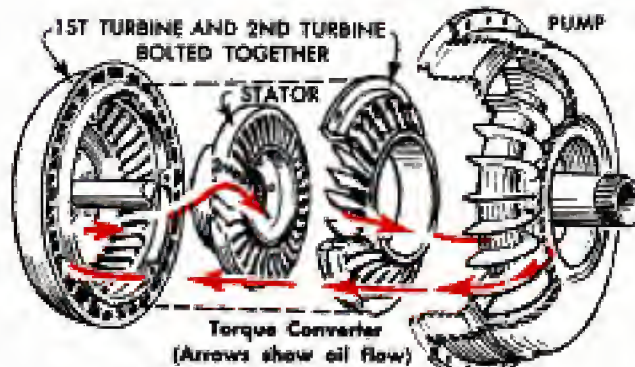

● The torque converter is basically a fluid coupling plus an additional bladed ring called a stator (because it remains stationary when in operation). The oil, set in motion by the pump, comes off the turbine blades with some of its power yet unspent. The stator blades deflect this oil against a second set of turbine blades and thus make use of its unspent power. This added thrust gives a "lower gear" effect. The lower the car speed, the more unspent power is in the oil when it leaves the first turbine. When the car hits about 40 miles per hour or when the speed of the turbine matches that of the pump, the deflected oil can no longer provide added thrust. Then the stator revolves with the turbines and has no function and the converter is a simple fluid coupling.

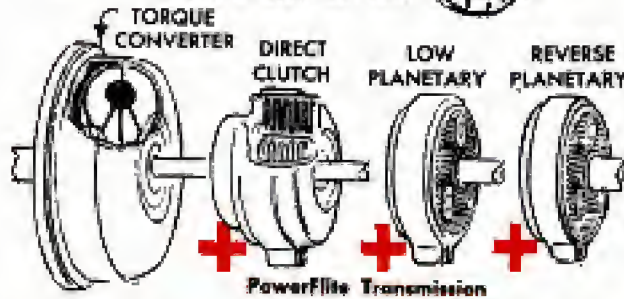

Like the fluid coupling, the converter is a clutch at idling speed so no clutch pedal is needed. It has limited torque multiplication and is usually used with planetary gears for acceleration and hard pulls. A second planetary provides reverse gear. When it becomes a fluid coupling, the converter has some slippage. To eliminate it, some transmissions bypass the converter at highway speeds. However, most use the converter at all times, locking out only the planetaries for cruising.

Schematic sketch of Chrysler's torque-converter transmission. Direct clutch locks the planetary units of use during normal highway driving. For fast pick-up, the low planetary cuts in. Most torque-converter transmissions are similar, differences being in controls

Plymouth's HyDrive is unique—a torque converter plus a synchromesh transmission. The added "gearing" of the converter enables the car to start from a standstill in high gear.

Hotchkiss Drive

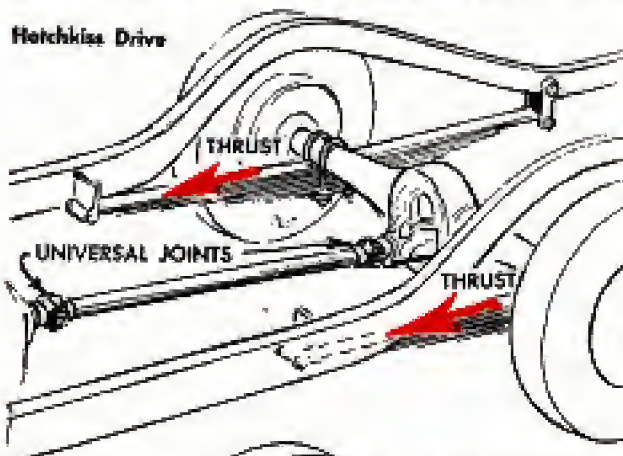

### ITS DRIVE SHAFT AND REAR AXLE

From the transmission, the turning force or torque goes to the rear wheels via the drive shaft. Two types are used in this country: The Hotchkiss and the torque tube. Most current U.S. cars have Hotchkiss drive.

Torque-Tube Drive

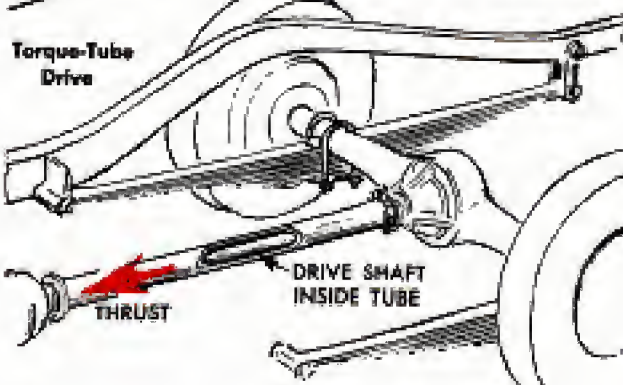

● With Hotchkiss, two or more universal joints are used. As the drive shaft starts to turn the rear wheels, a tremendous torque or twist is transferred to the axle housing. The rear springs absorb this force. Forward movement of the car comes from the thrust on the front end of each rear spring.

● The torque-tube drive shaft is enclosed in a steel tube, bolted at the rear to the axle housing, at the front to the transmission. Only one universal (at the front) is used. This tube absorbs the twist from the axle housing, relieving the springs of that job. Forward movement of the car comes from the thrust of the torque tube on the transmission case.

● In the center of the rear axle is the differential with its ring gear. The differential permits one rear wheel to go at a different speed from the other so the car will go around curves without tire scuff. The ring gear and its pinion provide the rear-axle ratio that determines how many revolutions your engine must make to move the car a given distance. A ratio of 4:1, for example, gives better pull and acceleration, less economy and top speed. A ratio of 3.5:1 sacrifices pull and getaway for higher top speed and economy.

**ITS SUSPENSION**

To keep your car on the road, to make it ride comfortably and steer safely, a well-designed suspension system is necessary. Springs, shock absorbers, stabilizers and frames make up the suspension system.

● Front-wheel suspension is independent on all American cars today. Either front wheel can go up or down when it hits a hole or bump without disturbing the other. No continuous axle connects the front wheels, each wheel being fastened to the frame individually. Most front springs are coil and, in many cases, the shock absorbers are mounted inside the coil.

Rear-wheel suspension is nonindependent on American cars. The rear axle is inside a solid, continuous housing that makes independent wheel movement impossible. Leaf springs are most common in the rear, but coil springs are used occasionally.

**ITS BODY**

Finally, there must be a place for the driver and his passengers to sit, protected from weather and other hazards. The body provides this protection and, at the same time, performs other functions. It gives the car a streamlining to lessen wind resistance at high speeds. It also provides a medium for styling the automobile — of giving it an attractive and distinctive appearance.

● There are two different types of body construction. In the conventional method (used by the vast majority of American automobile companies), the body is built separately and then at the desired moment in the assembly operation, it is lowered on the chassis. (The chassis consists of the frame and the running gear such as wheels, engine and drive line.)

● The second and less common method is known as unit construction. In this type the body shell and chassis are built as a unit and the entire assembly serves as a frame for the running gear. ★ ★ ★

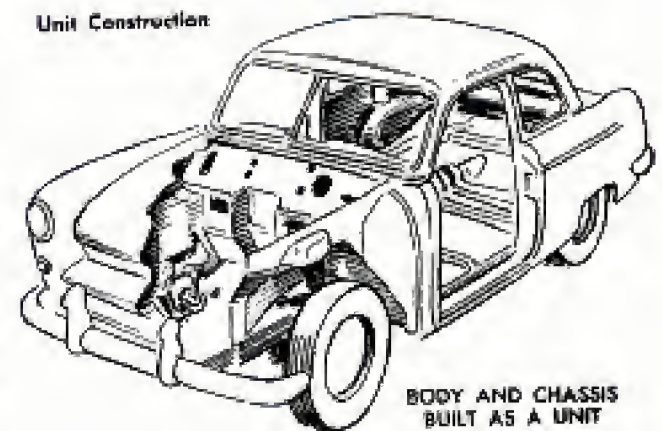
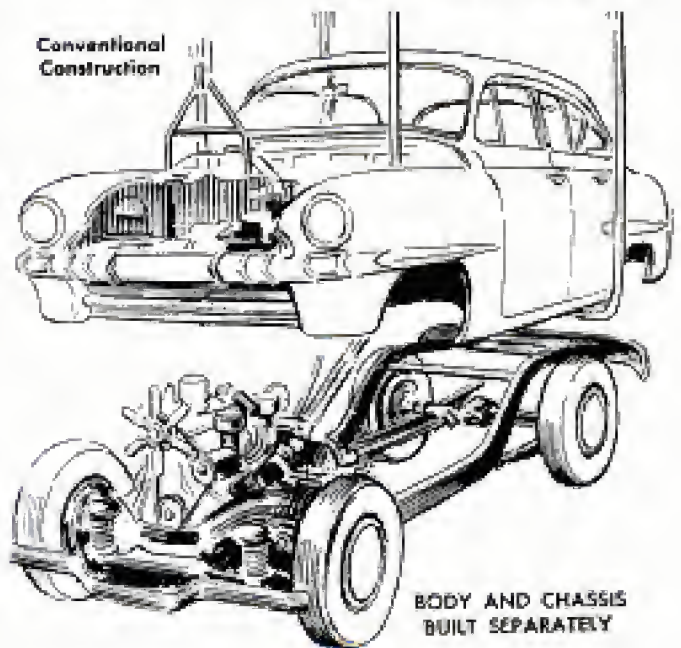
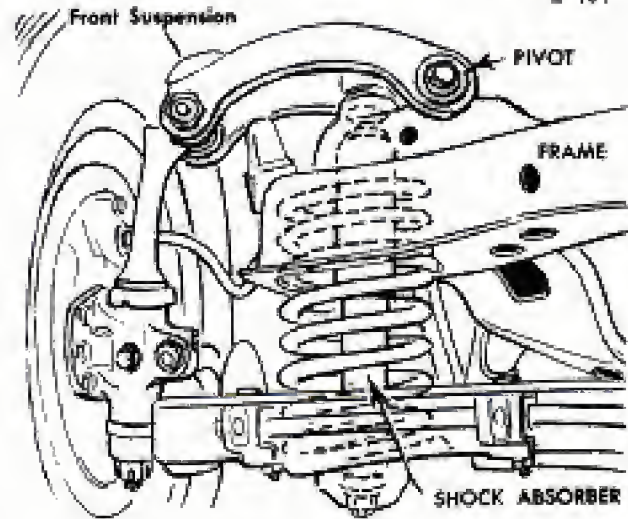
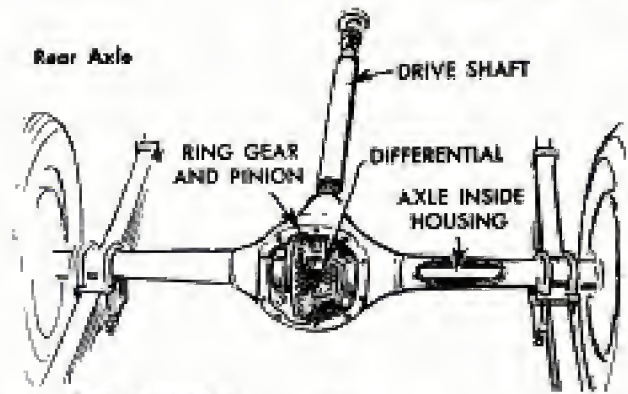

John Fitch, left, and Phil Walters, center, point out some interesting features on a map of Le Mans race course to *PM's* automotive editor, Art Railton, during their interview



For a first-hand account of an exciting sport, we asked the famed sports-car racing team of John Fitch and Phil Walters about . . .

## The Great Road Races of the World

**QUESTION:** As two of America's top sports-car drivers who have raced often in Europe, what do you consider the world's most challenging race?

**WALTERS:** I have never raced there, but from what I have heard about it from Fitch and others, I would say the Nurburgring in Germany.

**FITCH:** Yes, I agree. It is a driver's

course—a course where a good driver can be outstanding. The driver's importance is greater there than on any other course, I believe.

**Q:** Will you describe it?

**FITCH:** the Nurburgring is 14 miles of winding road in the Eifel Mountains of Germany—more or less a series of mountain passes. It is almost always in motion—

Fitch drives a Sunbeam Alpine up Stelvio Pass in the Alpine Rally. That zigzag line in valley is the road





uphill, downhill, turning right or left. Often both at once!

**Q: How many turns in the circuit?**

**FITCH:** I have heard anywhere between 178 and 184—my guess would be 180 curves in the 14 miles! Last year the sports-car race was 1000 kilometers long (that is 621 miles).

**Q: Is the driver more important there than the car itself?**

**FITCH:** In no race is the driver more important than the car. He has to have something to work with. But the driver is more important at Nurburgring than at Le Mans, for example.

**WALTERS:** In all these races, you are working against 99 percent good drivers so the car becomes the thing.

**Q: Which race is the toughest on the car?**

**WALTERS:** The French race at Le Mans, I think. It is also the one I would most like to win because it is the Indianapolis of sports-car racing. It is definitely the prestige race.

**Q: What makes it the tough race it is?**

**WALTERS:** The course is very smooth, the road is excellent and per mile there aren't too many turns so it doesn't present the challenge to the driver that other courses do. But the car takes a beating because you are running at very high speeds most of the time.

**FITCH:** There is a 3½-mile straightaway that just kills off cars right and left.

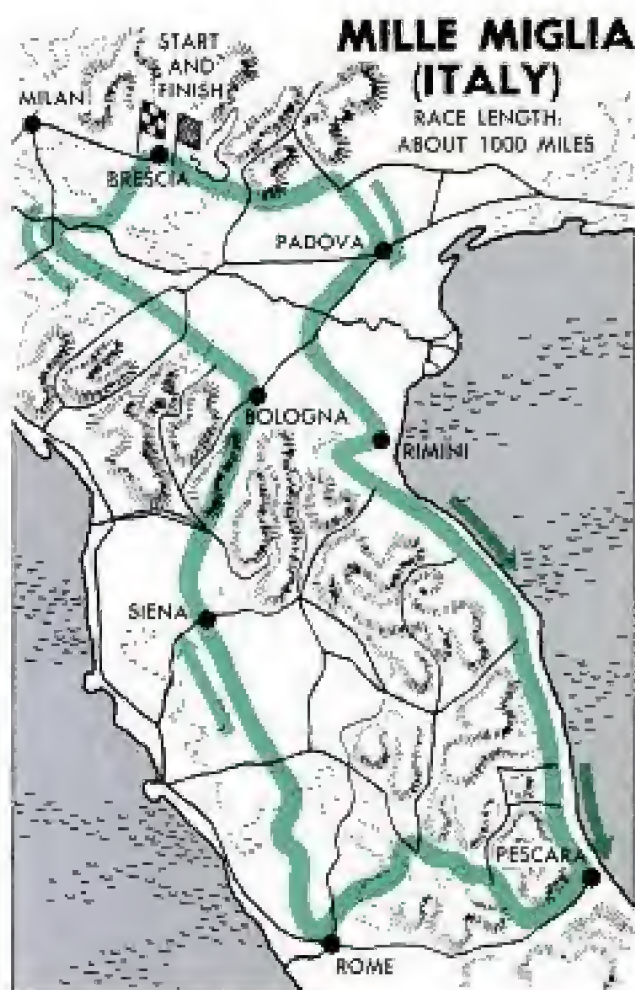

Above, the Mille Miglia runs 1000 miles on "narrow, winding roads through mountains." Below, Fitch was the first American to win a cup in the Alpine Rally

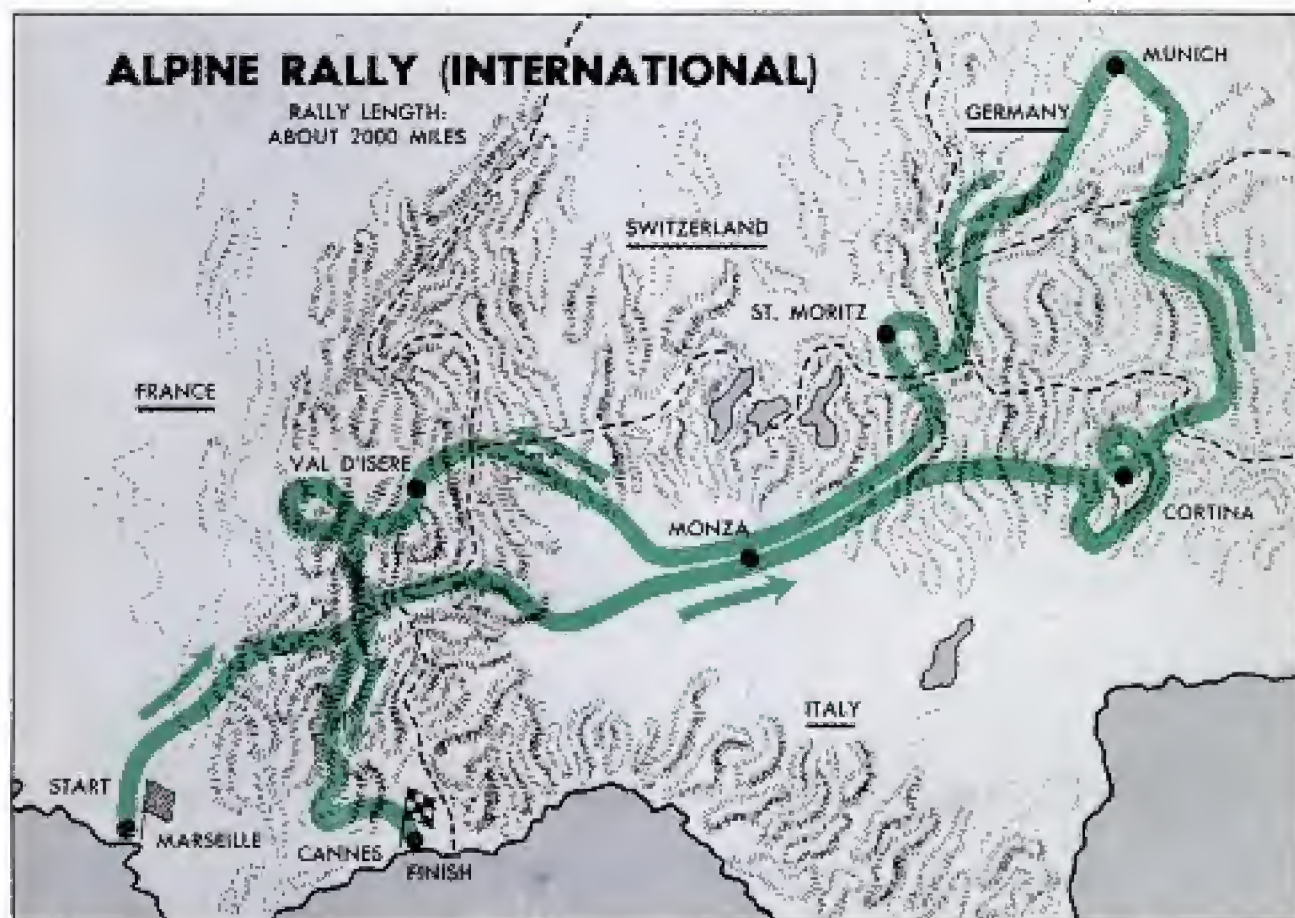

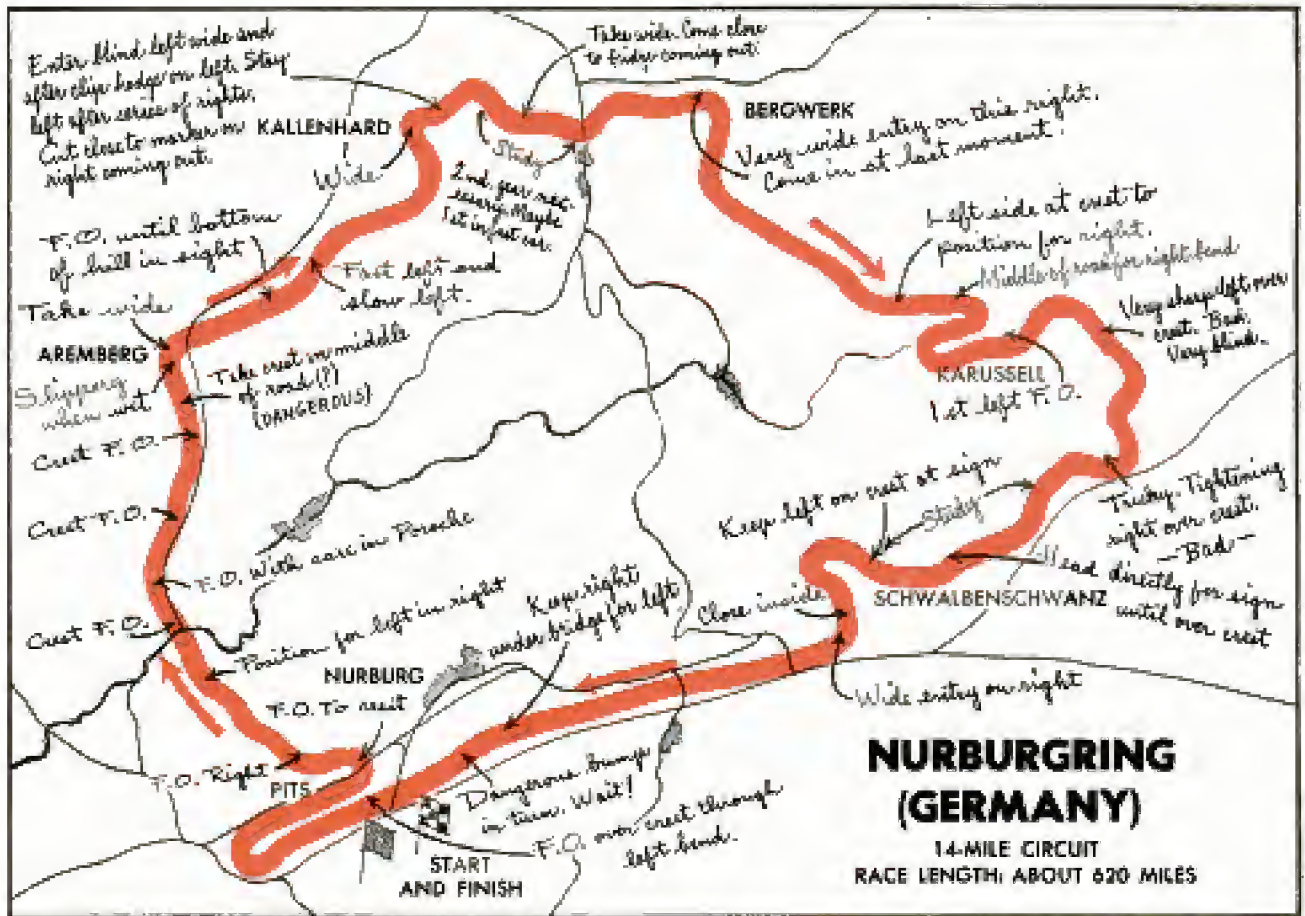

Below, hardest on the car is the 24-hour race at Le Mans, says Walters. It is also the one he "would most like to win . . . definitely the prestige race"

Above, most challenging race is Nurburgring, say both drivers. Notations were written on map by Fitch for study before race. F.O. means "full out" (wide open)

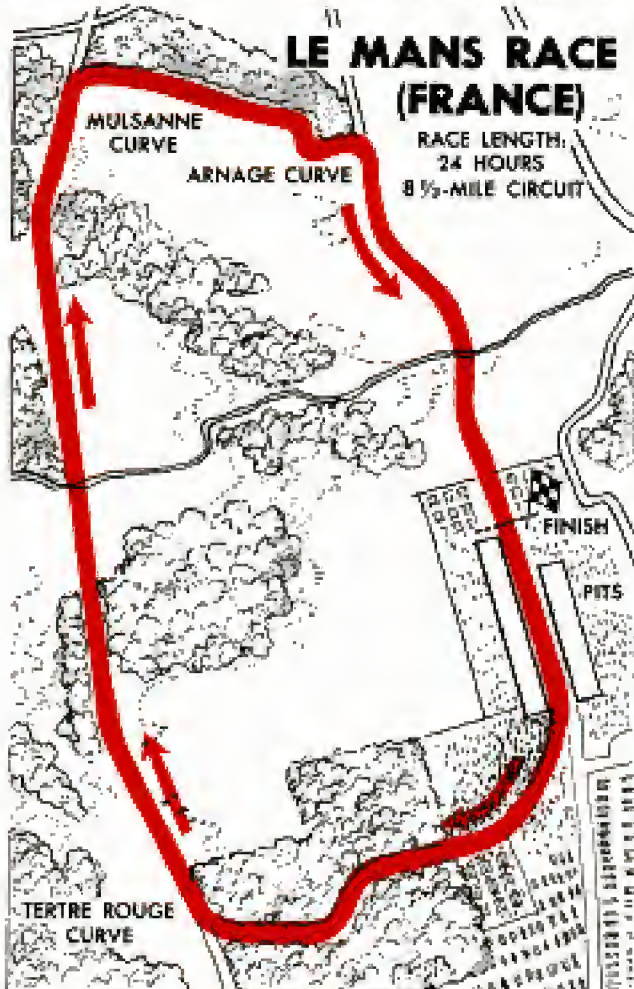

**WALTERS:** On the straightaway you can go as fast as any car can go. You hit speeds of 160 miles per hour. At the end of the straightaway there is a corner which you take at about 25!

**Q:** How long does it take you to slow down that much?

**FITCH:** As little as you can do it in. The short distance that the Jaguar needed to come down from its top speed is what won the race for it last year. It was the new spot brake that did it.

**Q:** Weren't there other changes as well as the brakes on the Jaguars?

**WALTERS:** Yes, but I would say that even without these other changes they would have won just on the basis of the new brakes.

**Q:** How long is the Le Mans circuit?

**WALTERS:** About 8½ miles around. It is a somewhat-better-than-normal French highway used the rest of the year for regular traffic. The crowds are tremendous, about 400,000, I believe. There is one very small main grandstand and temporary grandstands at various points around the course. There is standing room around most of the course.

**Q:** Do these Frenchmen stand up all night?

**WALTERS:** I imagine that no one person

stands there for the whole night, but at almost any time during the night you can look at the fence and see them five deep.

**Q: The length of the Le Mans race varies, doesn't it?**

**FITCH:** Yes. It is a 24-hour race and the faster you go, the longer the race is in miles. Last year, the Jaguars went about 2500 miles.

**Q: Can a driver drive the entire 24 hours or not?**

**WALTERS:** The most any one driver can drive is 18 hours and no more than six hours at one time. That's a new rule.

**FITCH:** Le Mans is the great race it is because of certain restrictions, like the one that requires you to carry all repair parts in the car—everything but tires, wheels and liquids, that is. You can't stop for fuel, oil or water until you have gone 28 laps or about 230 miles.

**Q: Can you stop for repairs before that?**

**WALTERS:** You can stop for repairs provided they can be accomplished with the parts and the tools you are carrying.

**FITCH:** Except for the jack and wheel hammer.

**Q: Both Le Mans and Nurburgring are closed circuits; what are some great cross-country road races?**

**FITCH:** The Mille Miglia, Italy's 1000-mile race, is one of the world's greatest and, of course, the Pan American Race in Mexico. These are the two best known, I suspect.

**Q: What is the difference between a closed-circuit race and a cross-country race—the difference to the driver, that is?**

**WALTERS:** There are two differences as far as the racing driver is concerned.

Left, a typical airport course. Right, Tourist Trophy is a "wild, seven-mile circuit circling the top of a mountain."

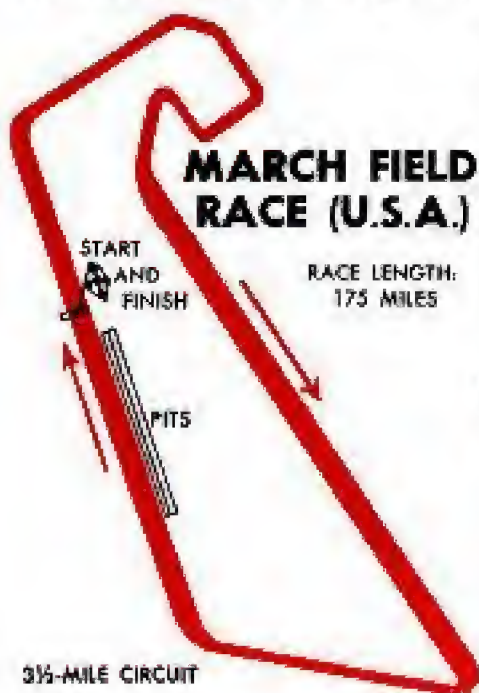

**FITCH:** "I went off the road at 140 miles per hour . . . thought I would never stop bouncing. The Cunningham went end over end once and I don't know how many times it rolled."

Even on the longer closed-circuit races, with laps 25 miles long, you get to know the course. You can memorize the course, so that you are going into every corner right up to the maximum. You know exactly where to brake for each corner. You know all about the road. However, on the cross-country race, particularly the Mexican race, it is impossible to memorize the course and you are driving below the maximum for each given situation because you don't know what it is until you get there. The second difference is that on a course like Le Mans it is, at the most, eight miles to the pit where you can get the help of a mechanic. On cross-country races, if any repairs are needed between the start and finish of a leg, they can be done only by the driver.

**FITCH:** I think pertinent to this difference between the Mexican race and a race like Le Mans is the nature of the road. In the Mexican race the car runs through a hairpin turn at 30 miles per hour, then goes straight for a hundred yards or maybe a mile to get up to 160 miles per hour or more, depending on the tightness of the pass or where the car happens to be in the pass.



Start of the 1953 Tourist Trophy. Fitch is driving car at right. He didn't finish. The car lost a wheel



Above, the wrecked Cunningham at Rheims. Driver Fitch was slightly hurt. Teammate Walters is at right



Above, Fitch drives a Cooper-Bristol Grand Prix car at Aix les Bains in France. He finished fourth. Below, Walters takes a curve at Sebring, Fla., airport in a Cunningham. Fitch was his teammate. They won



Also there is high altitude there and that has a secondary effect in that the surface of the road is very hot, being a heat-absorbing black, and therefore extremely hard on tires. Also in Mexico the road is repaired up until the race runs over it, so you can find at any time newly paved sections or a corner with loose gravel where you least expect to find it. In the first day's run, the route crosses two high mountain ranges with very winding roads and sharp turns. You run for an hour at a time climbing or descending, punishing engine and brakes severely.

**Q: What is the Mille Miglia like?**

**FITCH:** Well, it paralyzes Italy for a day—the time of the race that is. About 20,000,000 persons watch it, making it the biggest spectator event in history.

**Q: How long does the 1000-mile race last?**

**FITCH:** The winning car did it in less than 11 hours last year. But there were about 600 entries in the race and since the slowest cars start first, it takes much longer than that, about 22 hours in all. It is arranged so that just about the time the slow cars are getting into Brescia at the finish, the fast cars have worked through the whole pack and finish at about the same time.

**Q: What is the route, mountainous or level?**

**FITCH:** A combination. It goes across the Po valley, down pretty fast along the straight Adriatic coast where the leader averaged 112 miles per hour last year. Then across the mountains to Rome, up to Florence through the mountains again to Brescia where it both starts and finishes.

**Q: What kind of road is it?**

**FITCH:** A narrow, winding macadam road, which is the most vicious in the world when wet. It goes through some stiff mountain ranges, too. The Mille Miglia is almost impossible for a non-Italian to win. Last year's winner had courted his bride in Rome while living in Milan. For a couple of years he went back and forth so many times he learned every stone in the road.

**Q: Tell us about the Tourist Trophy in Ireland.**

**FITCH:** It is a wild, seven-mile circuit circling the top of a mountain outside Belfast and is one of the most difficult road circuits in the world. On each shoulder of the road there is an earthen bank about a foot or two high and there is just no place to go. You can't go off the road. If anything goes wrong, you just bounce around from one side to another until you finally stop, blocking the road. The high banks and hedgerows block the driver's vision, making lots of practice necessary to learn the road.

**Q: How long is that race?**

FITCH: In 1953, it was nine hours long. The winner completed more than 1000 kilometers, the F.I.A. requirement for being included among the world's sports-car championship races.

**Q: Would you rate the Mexican race among the top two or three races?**

FITCH: It is certainly one of the major races in the world.

**Q: Does it need stricter regulation?**

WALTERS: I feel that a Le Mans type of regulation, whereby the only parts that could be used (outside of liquids, wheels and tires) have to be carried on board, would make it a more interesting race. Something should be done to make it easier for the private entry. As it is, the team that comes down with the most parts and the most mechanics is more likely to win because they can do more in the three-hour work period permitted under the new rules. That gives the factory teams an edge.

**Q: In addition to sports-car road races, there are also Grand Prix races. What is the distinction?**

FITCH: The Grand Prix car is closer to the Indianapolis-type car, in looks at least. In fact, the Indianapolis cars are running today under an expired Grand Prix formula. The rest of the world has gone on to other formulas, but Indianapolis still retains the formula that was used in 1939, I believe.

WALTERS: The main difference is that an Indianapolis car has to accelerate well from 130 to 160 and it has to turn left well. A Grand Prix car has to accelerate well from 25 to 160 miles per hour, to stop well and to turn left or right well.

WALTERS: "The team that comes down to Mexico with the most parts and mechanics is most likely to win because they can do more in the three-hour work period . . ."



FITCH: On every kind of road surface. The races have every surface from cobblestones to billiard tables. It is the essential difference between road racing and track racing.

**Q: But how does the Grand Prix car differ from the sports car?**

WALTERS: A Grand Prix car is restricted only by rules limiting the engine displacement, whereas the sports car has many other restrictions. It has to be able to be licensed in most parts of the world.

FITCH: It is a legitimate road car with fenders, lights and so on.

**Q: But these sports cars that win the big championship races aren't standard production models, are they?**

WALTERS: No, most of them are prototypes, rather than production models. Suspension, weight, brakes and engine output are refined for competition. They eliminate all the comforts and niceties that you would require for road use. That saves weight. They wind up with an engine that is rough and won't idle. The car has a very poor ride. They eliminate upholstery, radio and heater, of course. It is nothing but a thinly disguised Grand Prix car—it is certainly not the same sports car you see driving along our highways today.

(Continued to page 286)

Mexico has one of the two outstanding cross-country races in the world. It has stock and sports entries

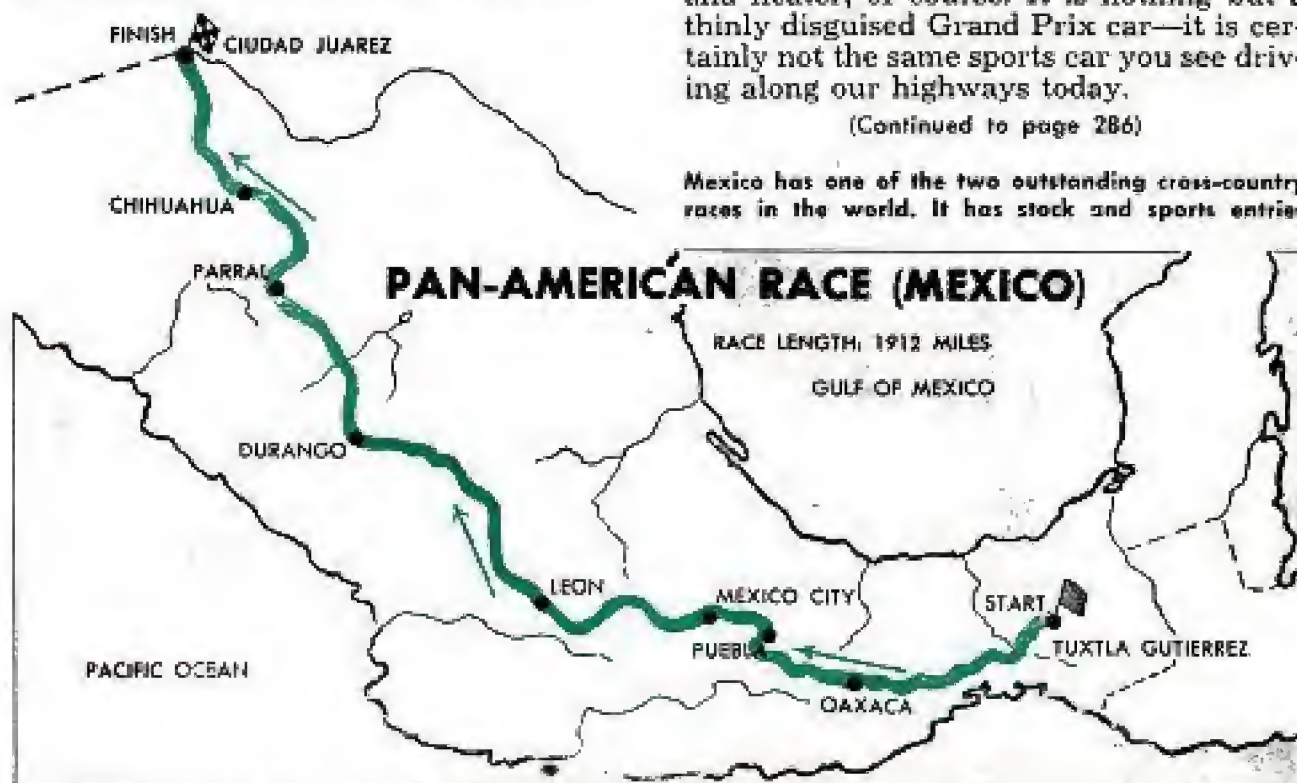

**THIS CAR  
COSTS \$2175.75**



**THIS CAR  
COSTS \$3910.80**

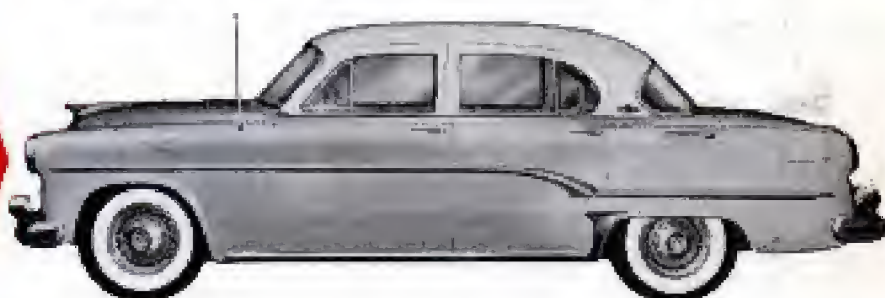

LOOK CAREFULLY at the two cars above. Both are 1954 Dodge V8s. Both are four-door sedans. Except for the paint, you might have trouble telling them apart. Yet, the price difference is \$1735.

The top car is a Dodge Meadowbrook V8. It is exactly what you get for the factory-delivered price—it has no extras.

The lower car is the new de luxe line introduced this year by Dodge, the Royal V8. A de luxe car to start with, it has everything added that Dodge offers.

Below are the various items that make

the Royal V8 worth over \$1700 more than the Meadowbrook V8. Those marked with an asterisk are standard on every Royal; the others are available at the buyer's option. Prices include federal excise tax, which amounts to \$272.90 on the Royal V8. Dodge is used here as an example; the "extra" situation applies to all makes.

For the average buyer, it is hard to say no to such extras; it is no wonder he is often surprised at the bill. Looking over this layout may help him realize he gets more than mere glitter for the extra money.

## HERE'S WHAT YOU GET FOR THAT EXTRA \$1735.05

- AIR CONDITIONER \$442.40
- CHROME WIRE WHEELS \$279.50
- TINTED WINDSHIELD \$21.50
- WHITE-WALL TIRES \$29.90
- HEATER \$78.25
- TWO-SPEED ELECTRIC WIPERS\* \$4.00
- GELUXE STEERING WHEEL \$7.40
- FOAM-RUBBER REAR-SEAT CUSHION\* \$5.85
- TURN SIGNALS\* \$13.95
- WINDSHIELD WASHER \$9.10
- POWERFLITE TRANSMISSION \$169.00
- STONE SHIELDS\* \$9.00
- CIGARETTE LIGHTER\* \$3.25
- GLARE-PROOF MIRROR \$3.45
- EXTRA CHROME TRIM\* (NO LIST PRICE)
- MAP LIGHT\* \$4.30
- ELECTRIC CLOCK \$17.10
- UNDERHOOD LIGHT \$3.25
- HAND-BRAKE FLASHER\* \$5.95
- GLOVE-COMPARTMENT LIGHT\* \$2.65
- BACK-UP LIGHT AND MATCHING GAS CAP\* \$8.00
- RADIO \$101.00
- POWER STEERING \$150.50
- TWO-TONE PAINT JOB \$12.90

X600

the

POPULAR MECHANICS

# CRAFTSMAN

## 3 SEWING CABINETS from SINGLE DESIGN

By John Bergen

*Style B*



*Style C*



*Style A*

ANY ONE OF THESE modern, good-looking sewing cabinets will do wonders to organize the clutter in the sewing room—and they make an ideal gift for the woman who likes to sew. Where space is at a premium, the attractive units serve a dual purpose as lamp or bedside tables. All three styles are adapted from a single basic design, each cabinet containing three convenient drawers and a pair of swing-out storage racks for thread spools and odds and ends.

The difference between styles A, B and C is merely in the design of the legs and exterior trim. The construction details of the style-A cabinet on the following two pages show how the cabinet itself is built for all three units. The changes in the legs and trim for styles B and C are given on

page 189. Walnut, oak, mahogany or other hardwood may be used for the legs and apron, with matching plywood for the panels and drawer and door fronts.

The bottom of style-A cabinet consists of a panel of 1/2-in. plywood set in a rabbeted frame, or apron, of 3/4 x 1 3/4-in. stock. The legs of this cabinet are splayed by attaching them to the corners of the apron with cleats as in the upper right-hand detail on page 186. The ends of the cleats must be cut at a compound angle to fit between adjacent sides of the apron and attain the 2-in. pitch of the legs.

The 1/2-in.-plywood side partitions are grooved for the drawer guides and rabbeted along the front edges to fit grooved posts of 3/4 x 1-in. stock. The rear edges of the side partitions are set in vertical grooves



Style A

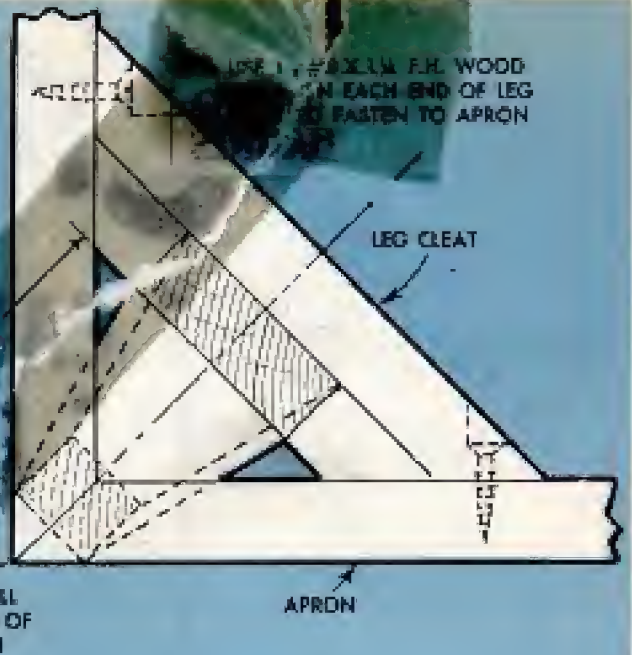

MITER ALL CORNERS OF APRON

APRON

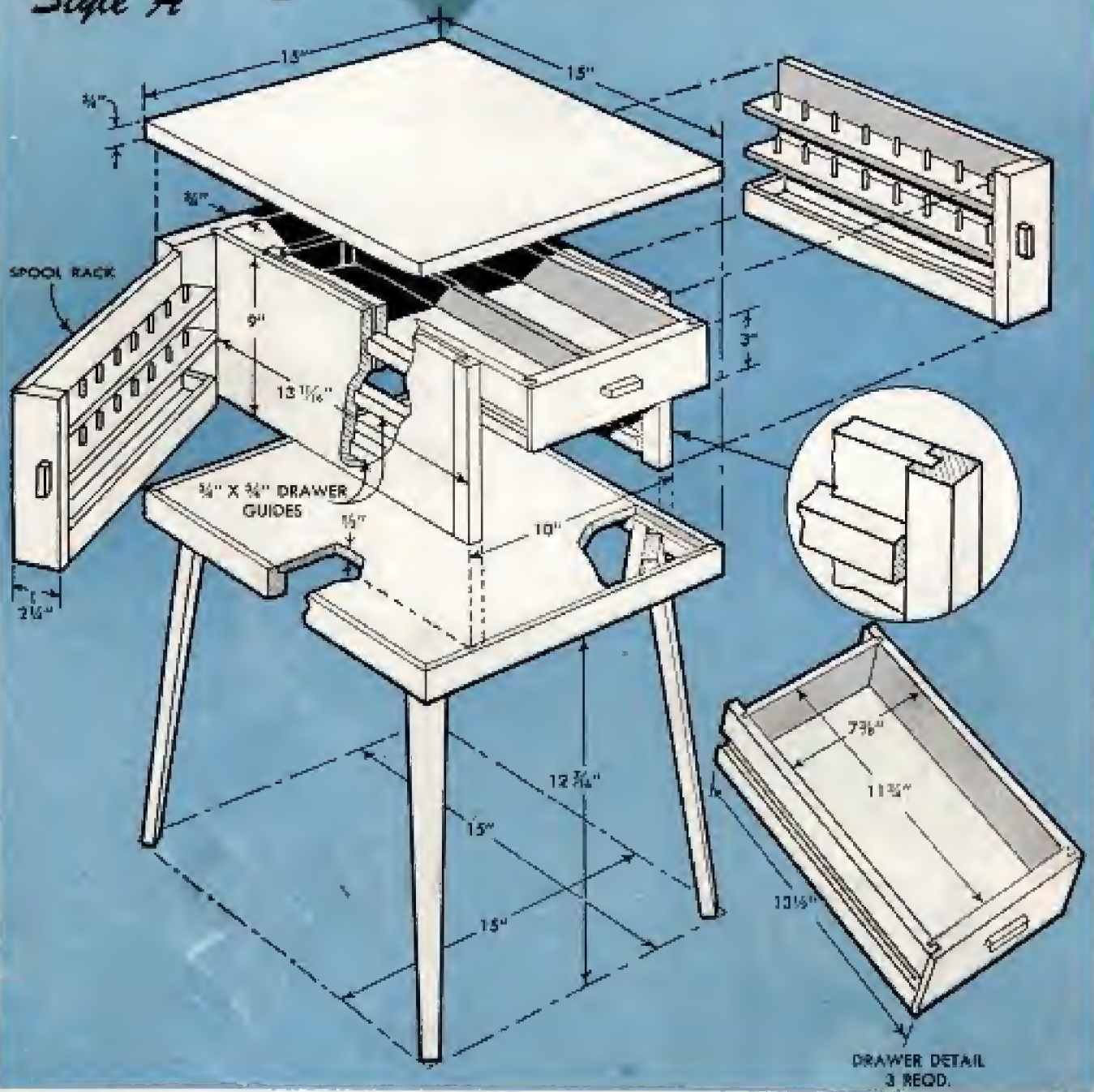



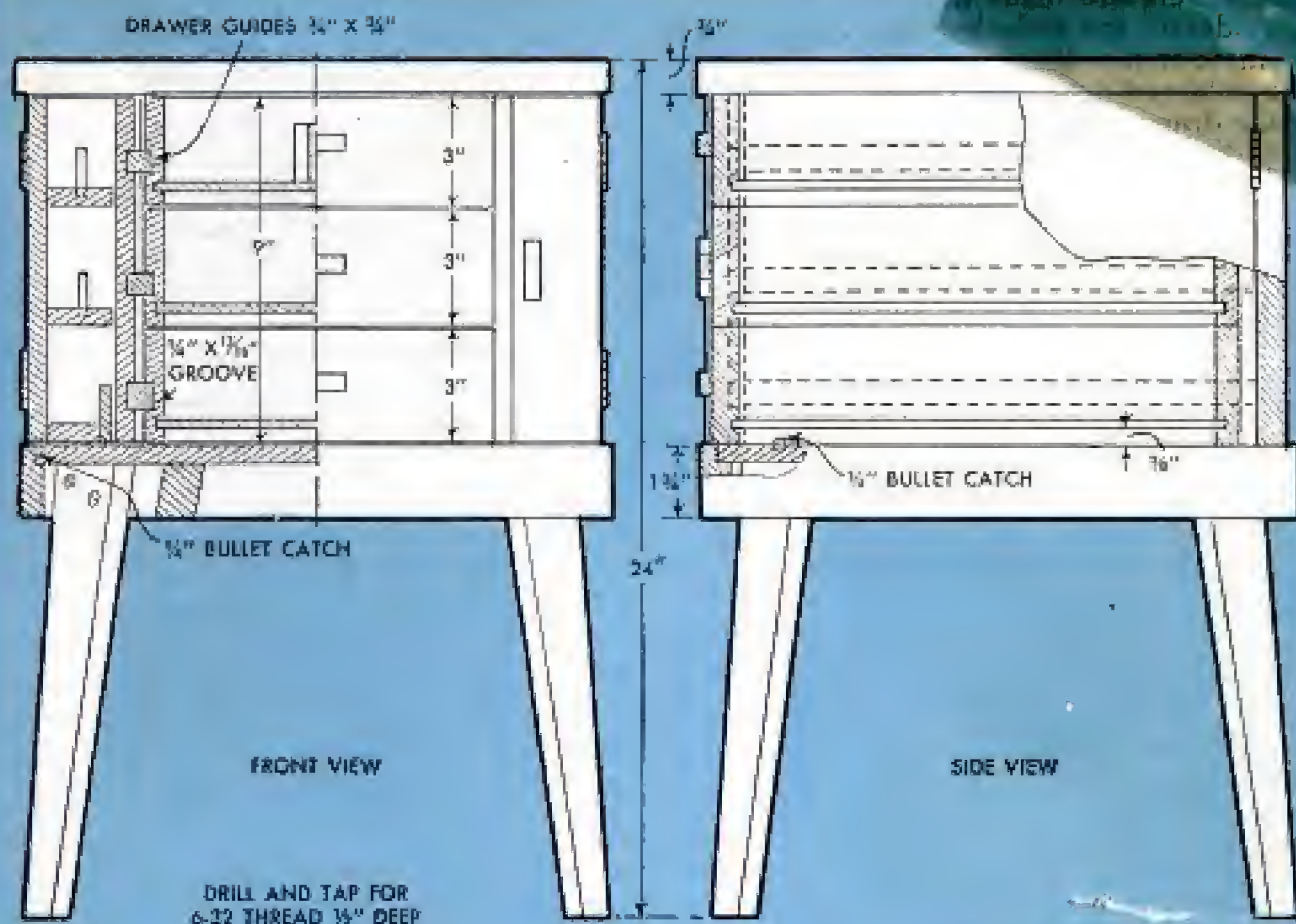

DRILL AND TAP FOR  
6-32 THREAD  $\frac{1}{2}''$  DEEP



BRASS DRAWER PULL  
BRUSH FINISH — 5 REQD.

1" X  $1\frac{1}{2}''$  OPEN BUTT HINGE

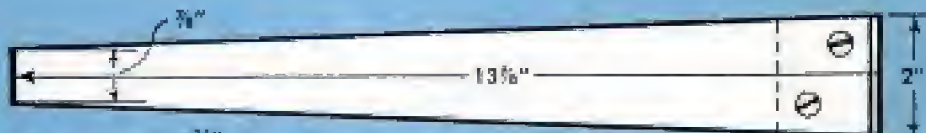

LEG DETAIL

$\frac{1}{2}'' \times 1\frac{1}{4}'' \times 5''$  CLEAT

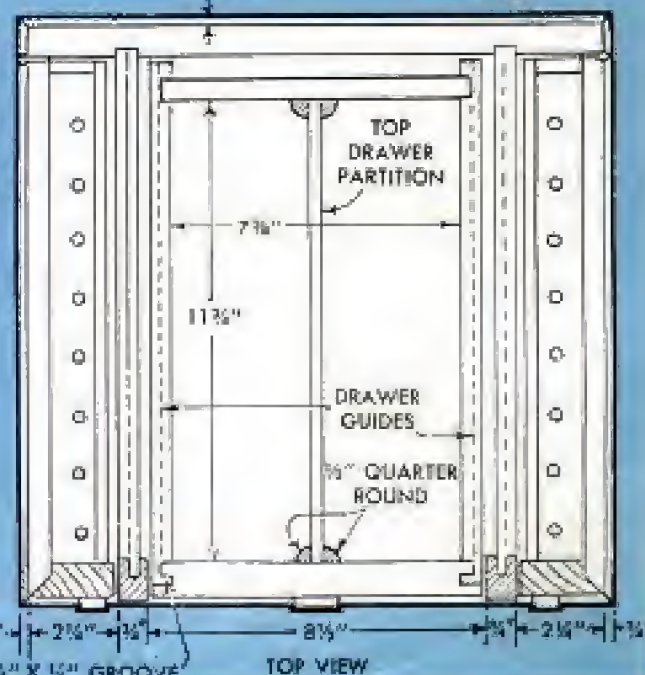
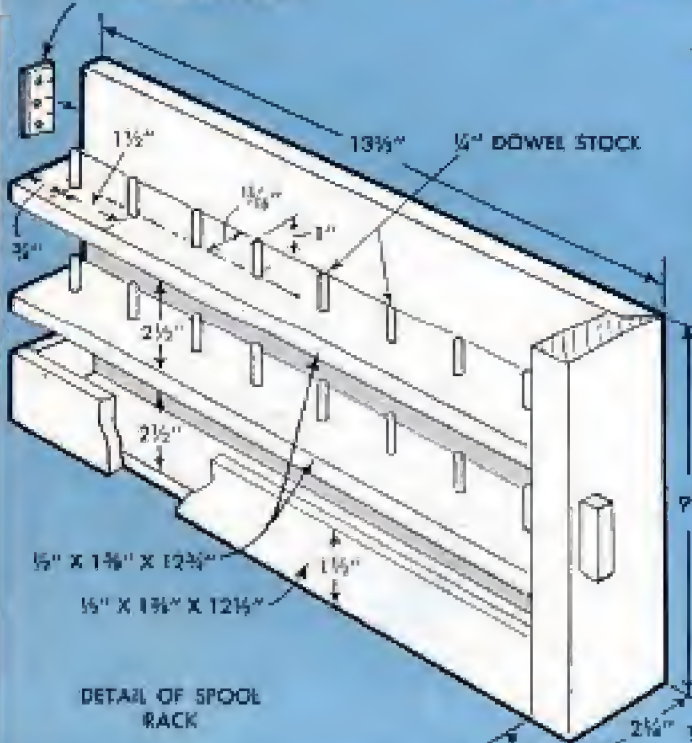

cut in the 3/4-in. plywood back panel. The three drawers are made as shown in the drawer detail, the sides being grooved 1/4 x 13/16-in. to engage the drawer guides. Note in the enlarged detail of the drawer posts how the drawer guide extends beyond the post to engage the groove in the drawer side. The drawer fronts are of 3/4-in. plywood, the sides and backs of 1/2-in. plywood and the bottoms of either 1/4-in. hardboard or plywood.

The swinging spool racks are made as in the lower left-hand detail on page 187, each one being hinged to the back panel with a pair of butt hinges. The front of each rack is of 3/4-in. plywood, with the other parts of 1/2-in. plywood. Drawer and door pulls are made of brass as shown in the detail, and the spool racks are held in the closed position with bullet catches.

Note in the style-B cabinet, detailed on the opposite page, that the top portions of the legs are shouldered for the apron. This, like the apron in style A, is of 3/4-in. stock. However, the upper corner of the apron is rounded to a 1/4-in. radius and the outer surface of the stock is planed to a 1/2-in. thickness at the lower edge. The sides and fronts of the hinged spool racks are grooved as indicated, and purchased brass knobs form matching door and drawer pulls.

The style-C cabinet differs from the others in its pedestal base and beaded inlay molding. The latter is 3/8 in. wide by 3/16 in. deep and is set in 3/16 x 3/16-in. grooves so that it projects 1/8 in. above the surface of the cabinet. In order to achieve the double-

strip effect across the cabinet drawers, the molding is glued in rabbets cut in the top and bottom edges of the center drawer. Antique-finished knobs are used on the drawers and doors of this cabinet.

The pedestal base of the style-C cabinet consists of a 3-in.-dia. turning and four curved feet which are doweled and glued to the turning. The base is mounted on the underside of the cabinet bottom panel with a 1 1/4-in. length of 1-in. dowel and a 6-in.-sq. cleat. The latter is made from 3/4-in. stock by rounding the edges and drilling the center for the 1-in. dowel. The cabinet bottom is drilled for the other end of the dowel. The cleat is fastened first to the end of the pedestal turning and the dowel is glued in the center hole of the cleat. After the base is completely assembled, it is fastened to the cabinet bottom with glue and countersunk screws.

The four feet are bandsawed from 1 1/2 x 4 x 12 1/4-in. stock and then worked to shape. The general contour of the feet can be determined from the cross-hatched sections shown in the detail, the upper portion being rounded at the top with the sides flat and brought gradually to the sectional shape shown for the portion of the lower curve. The upper end of each leg is sanded concave to match the radius of the pedestal turning and drilled for two 3/8-in. dowels. The legs are doweled and glued to the turning. Although the cleat is shown in correct relation to the cabinet in the front-view detail, the legs have been drawn 45 deg. out of position for clarity. ★ ★ ★

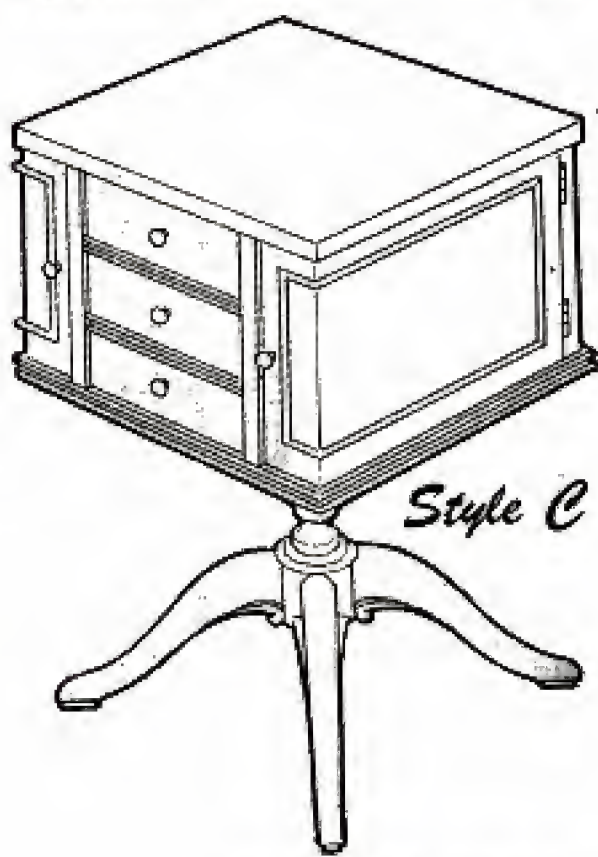
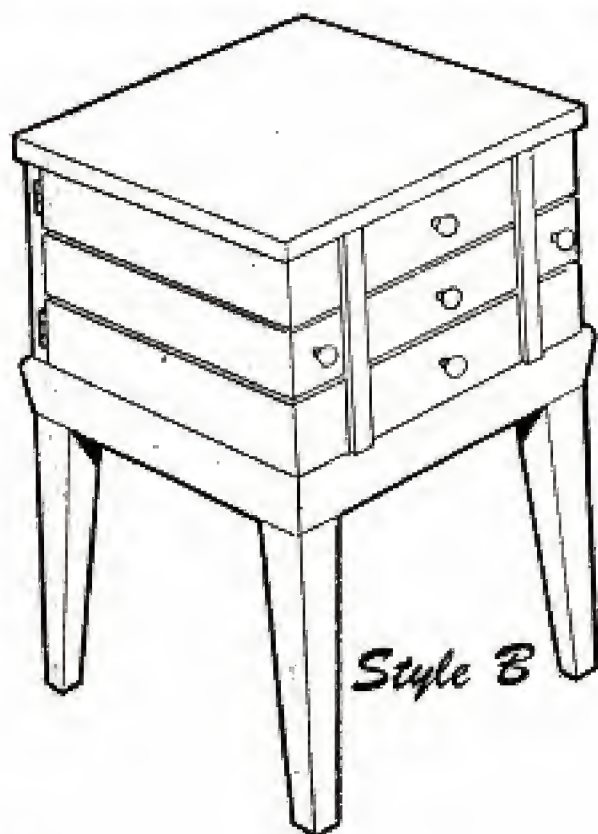

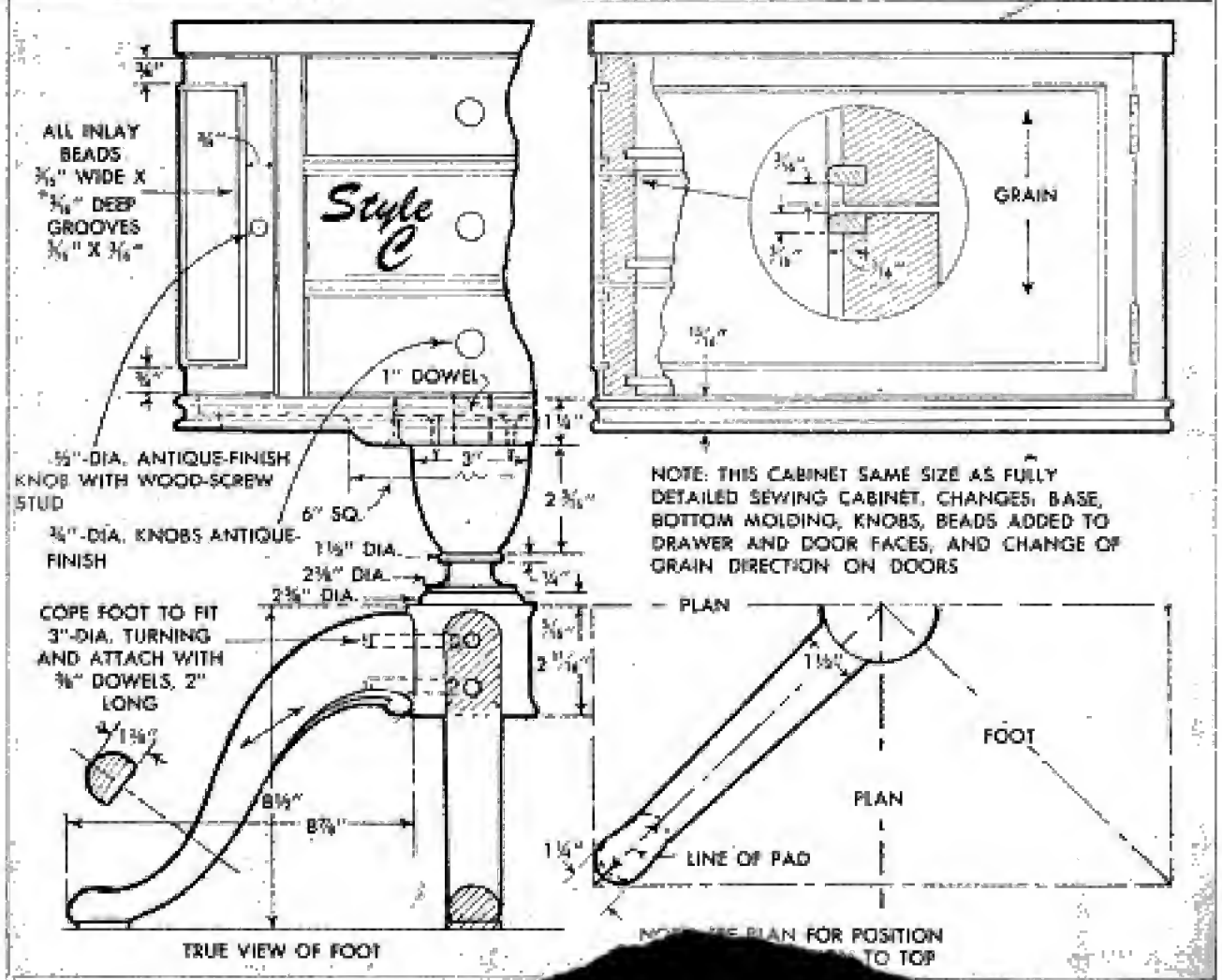
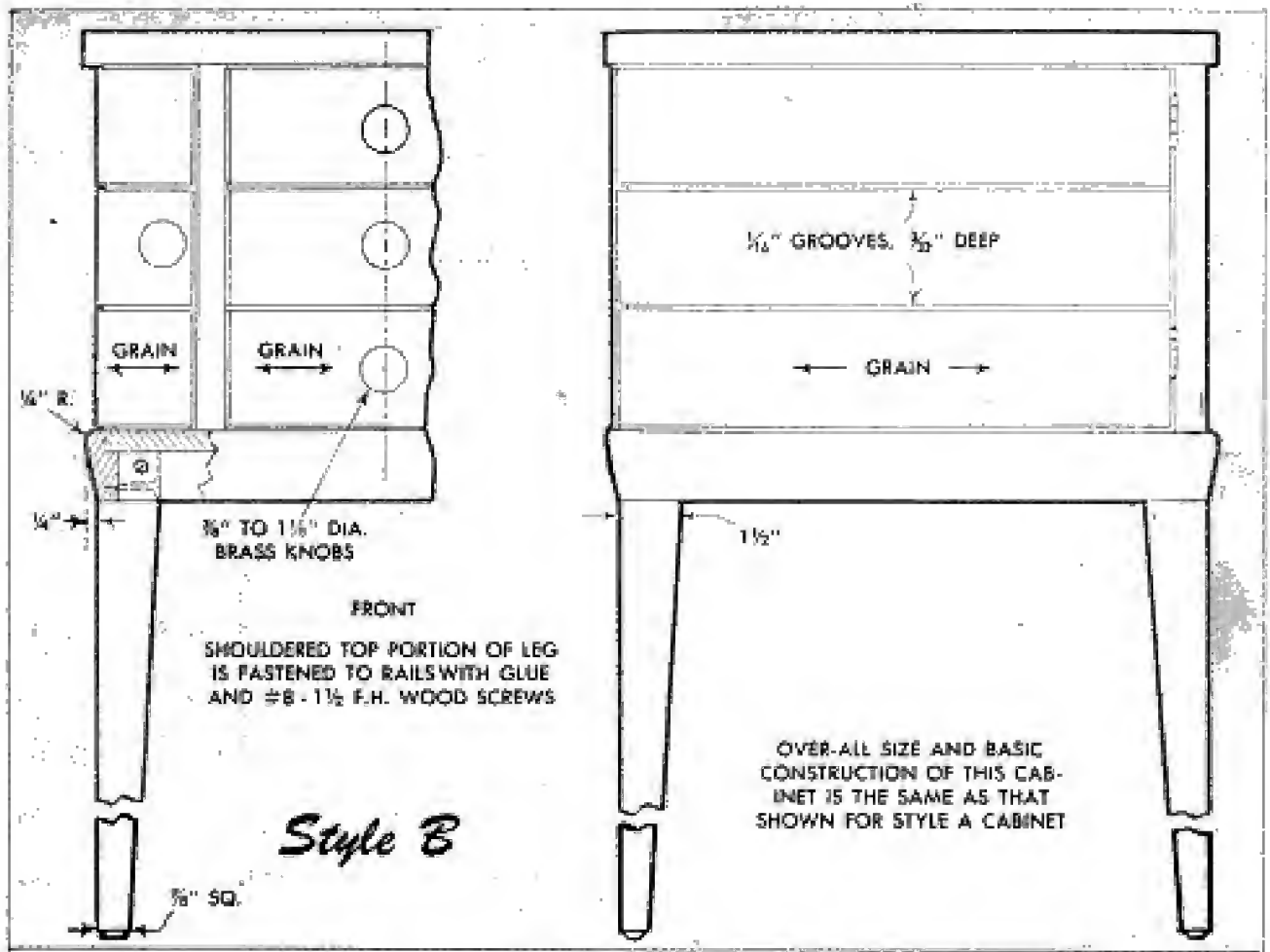

## Jig for Holding Wooden Frames Needs Only One Bar Clamp



With a number of identically shaped wooden frames to be glued and clamped, one craftsman used a jig fastened to the workbench to supplement his only bar clamp. The jig, made of hardwood strips, was accurately laid out and fastened securely to the bench top with large wood screws. The bar clamp was cradled beneath the bench in two U-shaped wooden brackets. The jig, being 1 in. shorter than the frame, permits the clamp to hold the joints tightly together.

Charles Mencio, San Antonio, Tex.

## Caliper Made From Broken Rule



A comparative caliper, useful for both inside and outside rough measurements, may be quickly shaped from a section of a broken folding rule. Two 6-in. sections are cut to the shape shown in the sketch, by cutting on a jigsaw or by

filing. A discarded rule will supply a number of these calipers.

George T. Hillman, Park Ridge, Ill.

## Dog Bed Provided by Old Tire

Needing a temporary bed for a mother dog and her pups, I simply placed an old automobile tire on the floor and laid

discarded garments in the center to furnish a pad. Both the tire and pad were then covered with an old woolen blanket and pressed down in the center so the tire formed sides of the bed.

Charles Rodrigues, South Carver, Mass.

## Slotted Sanding Block Provides Better Grip

A sanding block that is easily gripped can be made in a few moments by cutting slots in opposite edges of a short length of 2 x 4. Sandpaper is wrapped around the block and held in place by a heavy rubber band in the slot. In use, the fingers rest on the band in the slot, permitting a good grip and giving more control over the block than would be had otherwise.

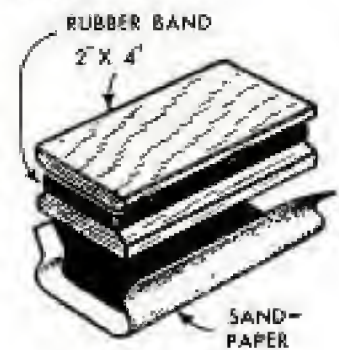

G. E. Hendrickson, Argyle, Wis.

## Simple Toy Teaches Child To Differentiate Shapes

Simple toy that will teach a child to differentiate between shapes, as well as give him pleasure, can be cut from a piece of wood or plastic 4 x 12 in. The stock should be at least 1/2 in. thick as it is easier for a child to handle. Lay out the puzzle according to the dimensions given and drill a hole in the corner of each shape for inserting a saw blade. A jigsaw or keyhole saw may be used. Sand the pieces smooth and finish with a nontoxic paint or stain.

I. M. Fenn, Chicago.

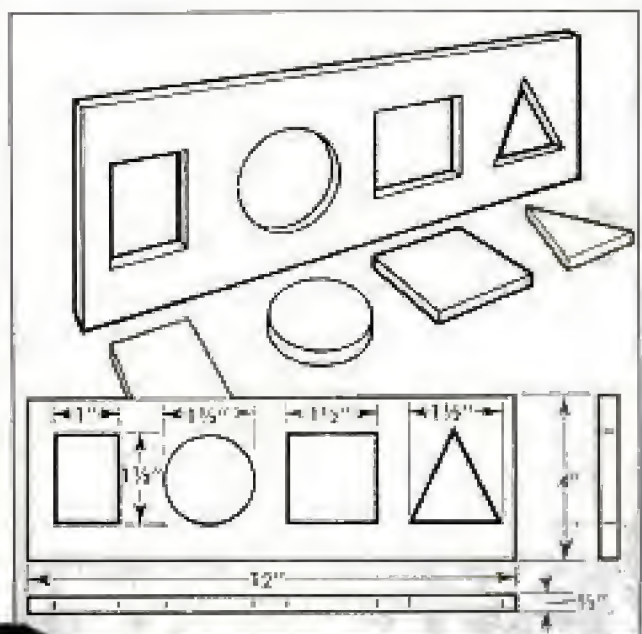

NOT M/53

# PULL TOY in eight models

By Hi Sibley

YOUNGSTERS WITH a liking for boats won't let Dad rest until he has collaborated with them in the making of this novel ship toy. There are eight ships to choose from, any one of which can be assembled on the same hull by means of interchangeable parts. That makes the job easier as only the parts of the upper structure are interchanged to make a freighter, ore carrier, liner, battleship or any of the four types of sailing vessels pictured in the lower photo. Certain parts such as the wheels, deck hatches, decks fore and aft, and the gun turrets are readily removable and replaceable on the hull by means of simple push pegs. The latter form axles for the wheels.

Before you make the hull, take time to go over the details on page 192 and also the various assemblies on page 193. Note that the parts have been dimensioned and keyed alphabetically, the letters running from A to X inclusive with the exception of the letters I and O, which have been purposely omitted. Note also that the part L is not indicated on the assemblies on page 193. Part L is a short length of dowel which holds the stacks in place on the freighter, liner, battleships and ore carrier. Parts for sailing boats, page 193, are lettered A to F inclusive.

For greatest durability make all parts of a hardwood such as maple or birch, and finish in the natural color of the wood. If you do use an opaque finish in color be sure that it is a nonpoisonous enamel or lacquer of the type made especially for finishing toys. The hull can be made from 1 3/4-in. stock as in the plan, side and end

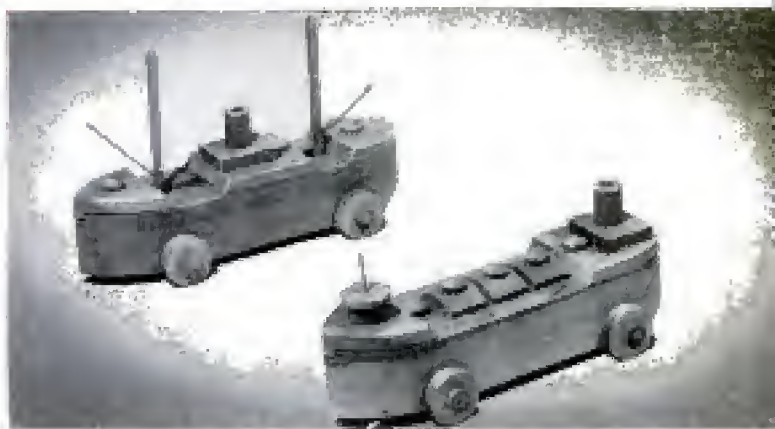
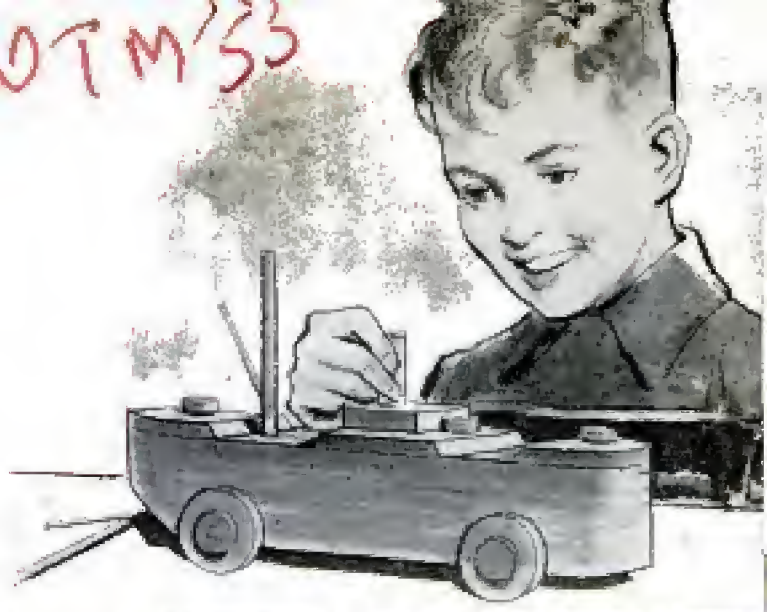

Two of eight types which can be built on same hull

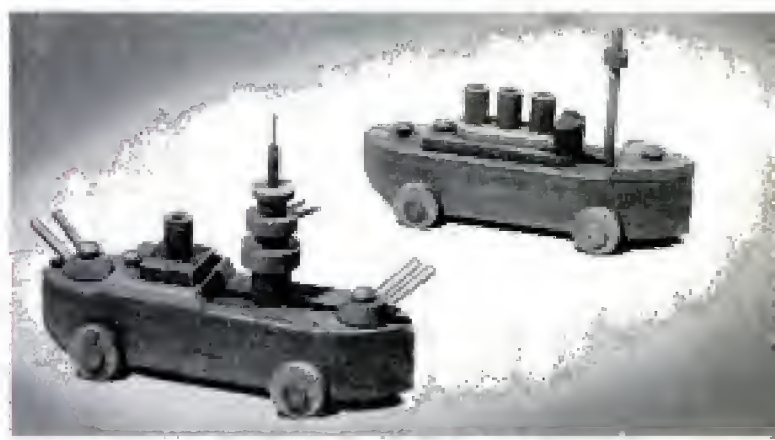

Above, battleship and liner are made with interchangeable parts. Below, four types of sail rigs can be set up on a single hull if desired. Note deck piece



Copyright



views, details A on page 192. Note that the bow, stern and midship deck pieces are rabbeted to form a tongue which fits into the groove cut lengthwise in the hull. This provision serves to automatically align the parts as they are placed in position on the hull. Also it will be noted that in turning the pegs, lower right-hand detail on page 192, they are shouldered to three diameters and are slotted at right angles to a depth of  $\frac{5}{8}$  in. from the small end. Although the diameter of the tenon at the end is given as  $\frac{5}{8}$  in., it is well to caliper this slightly over when turning to size so that it will fit snugly in the  $\frac{5}{8}$ -in. holes drilled in the hull. Masts are  $\frac{3}{8}$ -in. dowels rounded at one end and  $\frac{1}{8}$ -in. dowels form booms, bowsprit and crossarms. ★ ★ ★

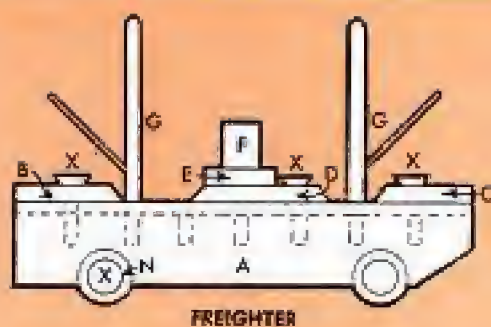
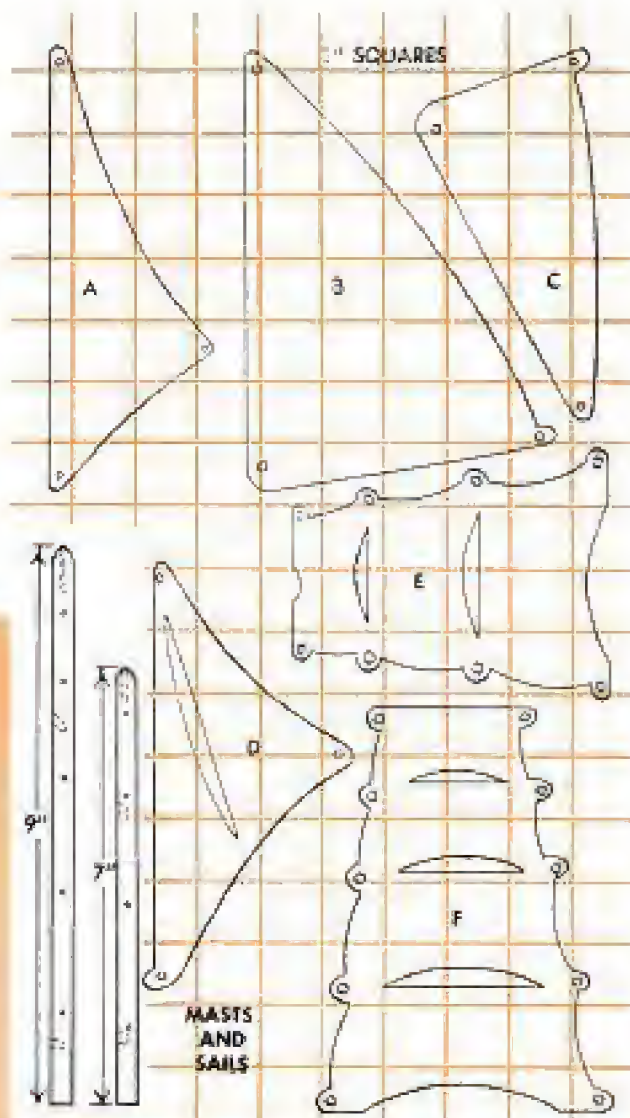

FREIGHTER

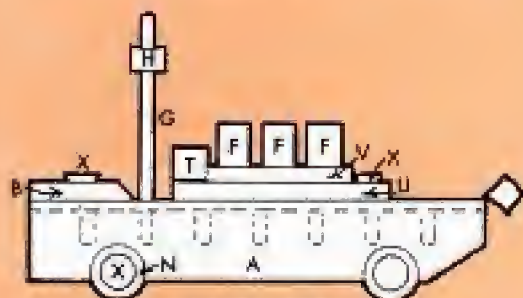

LUXURY LINER

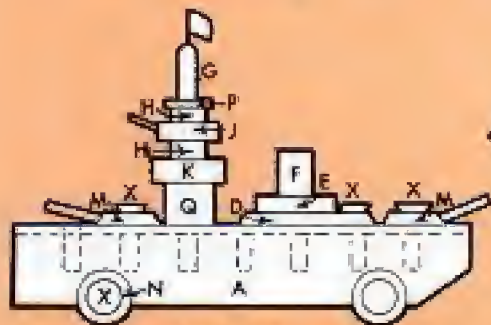

BATTLESHIP



ORE CARRIER

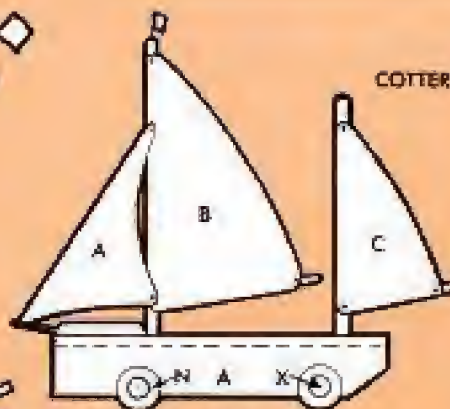

YAWL

COTTER PIN

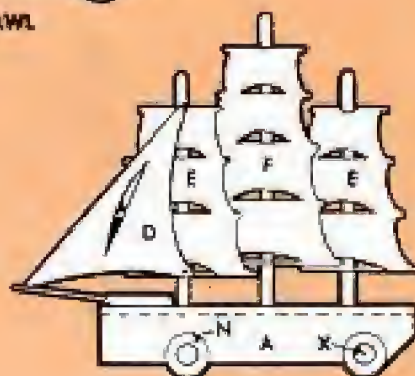

SQUARE RIGGER

## Automobile-Trunk Brackets Used As Folding-Table Supports



Seeking a more rigid method of support for his folding wall table than was possible with conventional wooden braces, one homeowner utilized the brackets from an automobile trunk. The brackets, taken from an old junked car, were modified by bending the upper ends to fit flush beneath the table top. The lower ends were fastened to wooden blocks which were screwed to the wall. Raising the table top slightly unlatches the trunk braces.

Richard Hamann, Fort Dodge, Iowa.

## Rubber Hose Over Pliers Handle Prevents Hand Chafing

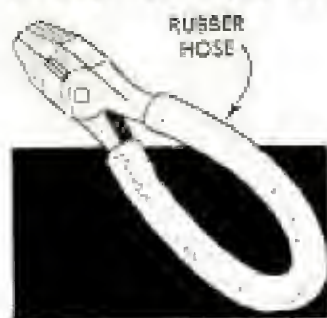

To prevent his hand from becoming chafed due to the repeated use of a pair of pliers, one home craftsman slipped a length of rubber hose over the handles. Besides protecting the hand, the hose

allows the pliers to be removed from a deep tool pocket without the handles snagging the inside of the pocket. The rubber hose also insulates the pliers.

R. R. Rundell, Miami, Fla.

## Nails to Hang Pictures on Wall "Driven" With Hand Drill

To provide "hooks" for hanging pictures on plaster walls without damaging the plaster, first clip off the head of a nail, file off any burrs that remain and chuck the

point in a hand drill. Then drill the nail into the wall at a 45-deg. angle and release when it extends about  $\frac{1}{2}$  in. As an added precaution, a strip of cellulose tape applied over the spot to be drilled will help reinforce the plaster as the nail is turned in place.—Martin Mantell, Hazleton, Pa.

## Adjustable Drafting Curve From Hacksaw Blade

Utilizing the flexibility of a hacksaw blade, this adjustable drafting curve will be found handy by the home craftsman for laying out patterns. The blade is held at the desired curve by an adjustable wire handle. The teeth

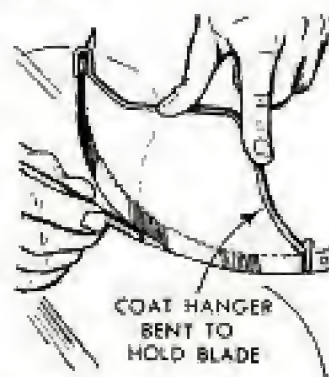

of the hacksaw blade grip the ends of the handle to prevent slipping. To make a compound curve or parabola, increase the bend in one end of the handle over the other.

Carl S. Bates, Chicago.

## Vapors of Solvents Utilized For More Economical Use

Solvents, such as lacquer thinner, may be used more economically by utilizing their vapors to remove paint from objects small enough to be placed in an airtight container. The example in the picture shows the paint being removed from the spots on a set of dominoes, preparatory to respotting them. The dominoes were placed in a coffee can, a tablespoonful of lacquer thinner was added and the lid placed on tightly. After 24 hours the paint was soft enough to be wiped off. Other highly volatile solvents may be used in the same way.

Walter E. Burton, Akron, Ohio.





# DON'T LET DUSTY HOLDERS SPOIL YOUR NEGATIVES

By Donald F. Honick

Before loading your film holders, spend a few minutes cleaning them with a soft brush and a syringe, to assure clean, dust-free negatives. The required tools are a clean  $\frac{3}{4}$  or 1-in. camel's-hair paintbrush and a small ear syringe, the latter being obtainable at most drug stores. First, remove the film-holder slide and use it to tap lightly along the front edge of the holder, Fig. 1, to dislodge dust and dirt particles. Then, with the ear syringe, Fig. 2, blow air through the felt light-trap to remove dirt not loosened by the tapping. Make sure the felt is thoroughly clean, because dirt from it will drop down onto the surface of the negative when the slide is inserted into the holder. Next, blow out the inside of the holder, Fig. 3, to remove the dust. Finally, brush the holder with the camel's-hair brush, Fig. 4. Cleaning the holders should be done, of course, in a location that is as dust-free as possible. A darkroom, equipped with an air conditioner that filters and dries the air, would be ideal. For most satisfactory results, film holders should be cleaned just before loading.



## Night-Flying Insects Controlled By Use of Proper Lighting

Because night-flying insects are color-blind—their eyes being sensitive only to blue and near ultraviolet light—it is actually a simple matter either to attract or keep them away, by using the correct color of light bulb. However, most bulbs, whatever their predominant color, produce a mixture of colors which includes blue. Although red or orange-colored bulbs would be just as effective, yellow is the color used in noninsect-attracting bulbs, because human eyes find the color pleasant. All fluorescent bulbs, except the gold-colored, are attractive to insects, and both blue and

black-light fluorescent bulbs have so much appeal that they are used as bait in insect traps. Florists, gardeners, farmers and other professional growers use these light traps to attract and destroy insects as a means of protecting their plants and trees.

General Electric News Bureau.

## Shellac Preserves Ball Bat

Baseball bats can be given a very durable finish by applying several successive coats of shellac. Sand each coat lightly after it has dried and buff to a high gloss.

# Solving HOME PROBLEMS



**CARRY YOUR CLOTHESBASKET** in the baby buggy to make the work easier when hanging the clothes out to dry. As a laundry cart, the buggy will hold the basket at a convenient height and can be moved along as the clothes are hung up or taken down

**WHEN PAINTING** door jambs, baseboards and other often-abused surfaces around the house, save a bit of the paint in an old nail-polish bottle. This will provide a color-matched, touch-up kit that is easy to use for covering up marks and scratches



**KEEP A SMALL TOOTHBRUSH** in the kitchen specifically for cleaning the beaters of your electric or hand mixer. With it you easily can reach all those hard-to-clean surfaces of the beaters in a short time

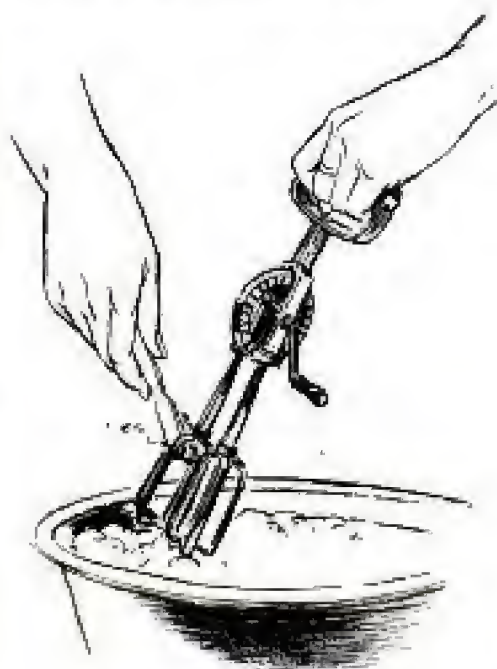



**SCREEN-DOOR BRACES** can be used to provide additional support for the floor of a folding playpen if they are attached as shown. Four braces, which will also give strength to the sides, are needed



**MOTH CRYSTALS** placed inside an empty adhesive-tape spool as shown, and slipped over a clothes hook in the closet will keep the moths out and yet last a long time due to slow evaporation



**A STICK OF BLACKBOARD CHALK** kept in your jewelry box will help prevent tarnish from forming on your costume jewelry. The same idea can be used in chests of silverware and other cabinets where metal objects subject to tarnish are stored



**PIVOTED ON A NAIL** or wood screw, a pie plate or cake pan can be made into a handy revolving tray for storing spices. Mounted on the kitchen shelf with a washer between the pan and shelf, it is allowed to overhang the shelf edge for easier pivoting



**FADED AND DINGY CARPET** can be restored in color if it is sponged, a small portion at a time, with hot water to which a little ammonia has been added. Rub the area of the carpet dry after sponging

## Make Full-Color Image Projector Using Ordinary Camera Lens



Capable of producing full-color, larger-than-life-size images, this projector can be constructed in a matter of minutes. A large cardboard box, a portable extension light and the lens from a camera are the essential parts. A hole is cut in the bottom of the box, into which the lens is fitted. The light, which must be of the type that has a shield on one side of the bulb, is fastened inside the box with the shield toward the lens. The object to be projected is placed in the box and then a dark cloth is used to close the open side of the box. The image is focused by moving the object toward or away from the lens, while the size of the image is governed by the distance from the lens to the surface used to show the picture. The object should be placed upside down in the box.—Frank Maxlin, Azusa, Calif.

## Removing Wax From Wallpaper

To remove candle wax from wallpaper, scrape most of it off with a dull knife and then place a blotter over the remaining spot. Press the blotter with a warm iron. This will soften the wax, which will then be absorbed by the blotter.

Sam Fenn, Chicago.

## Kinks in Copper Tubing Removed With Aid of Wooden Paddle

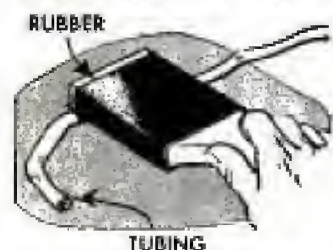

To facilitate the removal of kinks and bends from a length of copper tubing, use a wooden paddle covered with a wide band cut from

an inner tube as shown. Use the paddle to apply pressure to the irregular portions while rolling and working the tubing back and forth on the bench.

## Wheel Disks for Model Cars Are Furniture Gliders

One modelmaker solved the problem of finding suitable wheel disks and hub caps for the wheels of his model cars by using furniture gliders. The dome-shaped gliders come in several sizes to match various wheel diameters. To install the gliders, cut slots in the wheels as shown, insert the prongs of the glider and clinch the ends.

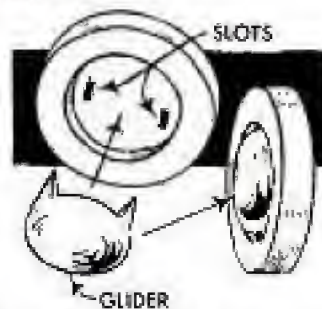

H. Radzinsky, New York City.

## Painting Over Varnish or Enamel With Oil-Base Paints

When applying oil-base paint over varnish or enamel, the job of sanding the surface or washing it with sal soda, can be eliminated by adding benzol to the paint. Two ounces of benzol added to each gallon will allow the paint to be applied directly to the old finish without prior preparation. The benzol is used on the first coat only. Subsequent paintings are done with the regular paint. Caution: Benzol is highly flammable and should be kept away from fire and heat.—O. A. Nelson, Seattle, Wash.



Two glasses that are stuck together can be separated by placing the outside glass in warm water and at the same time pouring cold water into the inside glass.

# MODERN TABLE LAMP

By Bert Goldrath

THIS MODERN table lamp, tall enough to be used for reading even when placed on a fairly low table, may be made completely from one length of 1-in. lumber. If 1 x 16-in. stock is not available, a 4-ft. length of 1 x 10 may be used. Cut out the pieces of the lamp according to the dimensions given. A 1 3/4-in.-square block, cut from 1-in. stock, is fitted at the top and bottom of the lamp. The top block is drilled to receive a 1/8-in. pipe nipple, 2 in. long, which is held to the block with locknuts. The lamp is assembled without screws. After applying the glue, use two C-clamps at both bottom and top of the lamp. When the glue is dry, fasten a pull-chain socket and shade holder onto the pipe nipple. Before assembly, run a wire from the socket down through the lamp column to a hole drilled two inches from the bottom.

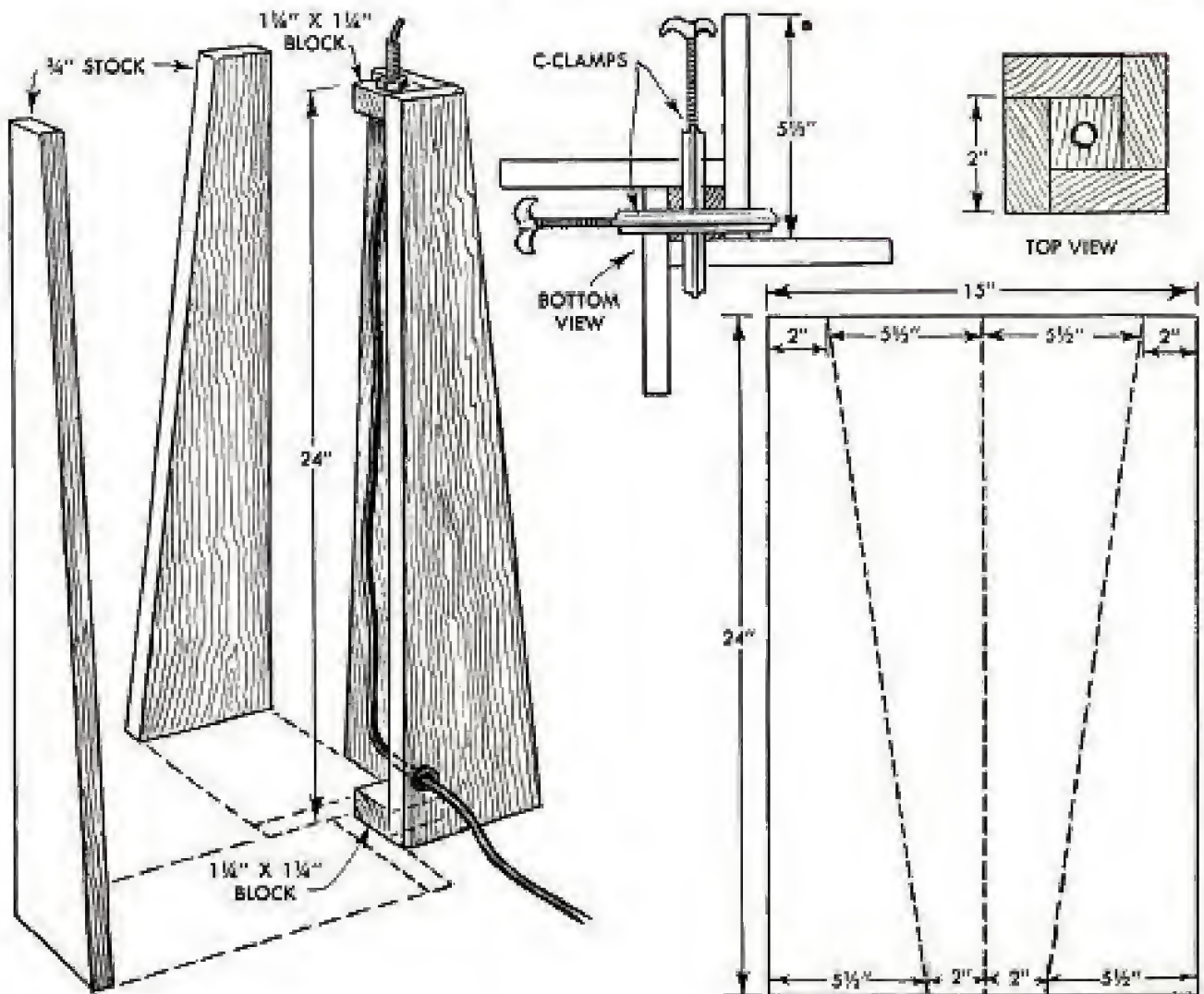

# PLAN of the MONTH

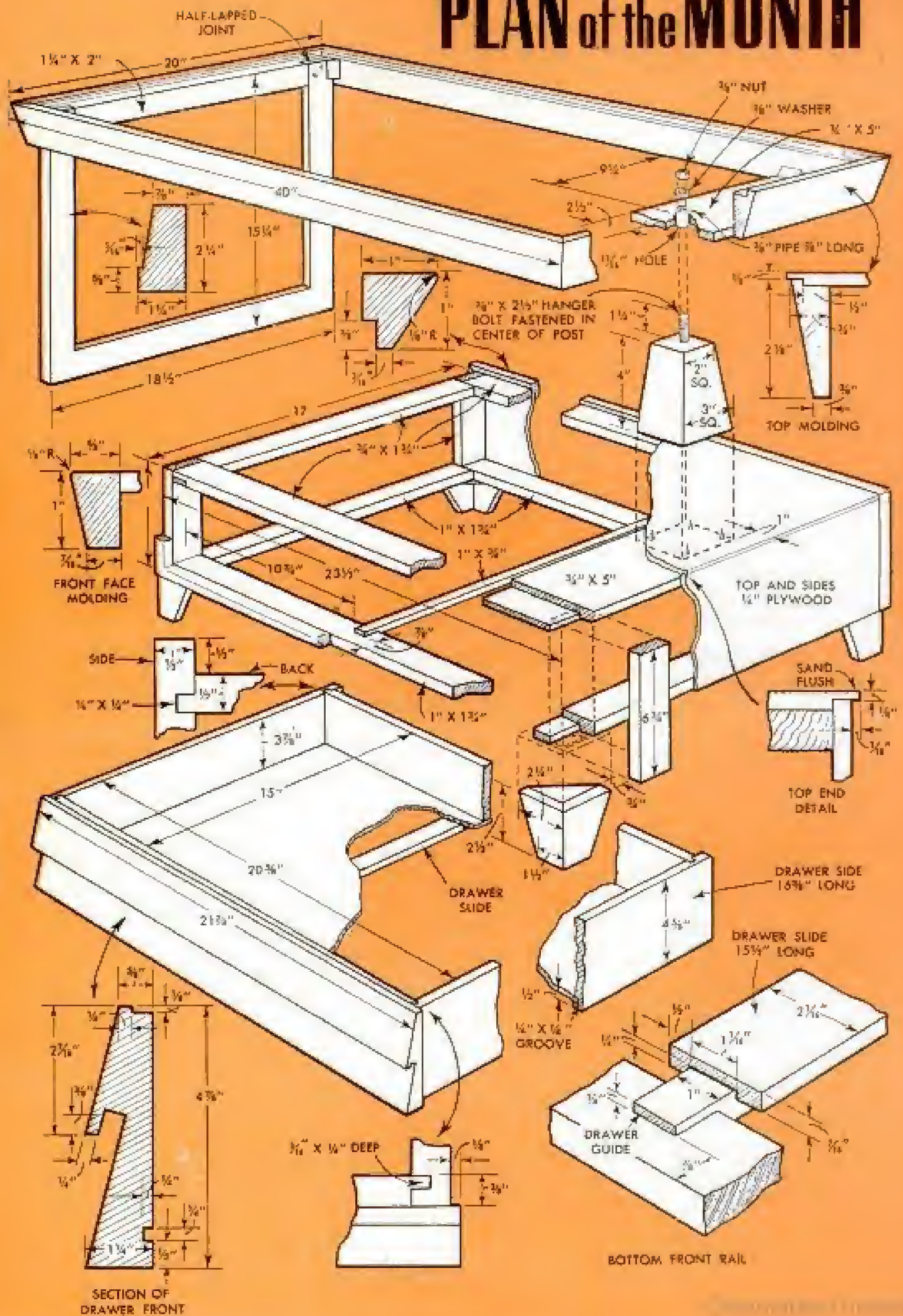

# Cocktail Table

WT-153  
Modern Furniture

## MATERIAL LIST

### Cabinet plywood

- 1 pc.— $\frac{1}{4}$ "x20 $\frac{1}{2}$ "x40 $\frac{1}{2}$ "—Top  
 1 pc.— $\frac{1}{4}$ "x17"x24 $\frac{1}{2}$ "—Cabinet top  
 2 pcs.— $\frac{1}{4}$ "x17"x8 $\frac{1}{2}$ "—Cabinet back  
 1 pc.— $\frac{1}{4}$ "x22 $\frac{1}{2}$ "x5 $\frac{1}{2}$ "—Cabinet back

### Plywood or hardboard

- 1 pc.— $\frac{1}{4}$ "x31 $\frac{1}{2}$ "x15 $\frac{1}{2}$ "—Drawer bottom

### Cabinet lumber

- 2 pcs.— $\frac{3}{4}$ "x2 $\frac{1}{2}$ "x40"—Top side rails  
 2 pcs.— $\frac{3}{4}$ "x2 $\frac{1}{2}$ "x20"—Top end rails  
 1 pc.—1 $\frac{1}{2}$ "x2 $\frac{1}{2}$ "x10 $\frac{1}{2}$ "—Bottom end frame  
 2 pcs.—1 $\frac{1}{2}$ "x2 $\frac{1}{2}$ "x15 $\frac{1}{2}$ "—Side end frame  
 1 pc.—1 $\frac{1}{2}$ "x2"x18 $\frac{1}{2}$ "—Top end frame  
 1 pc.—3"x3"x4"—Post  
 4 pcs.— $\frac{3}{4}$ "x1"x24"—Top and bottom cabinet frame  
 4 pcs.— $\frac{3}{4}$ "x1"x7"—Ends, cabinet frame  
 8 pcs.— $\frac{3}{4}$ "x2 $\frac{1}{2}$ "x2 $\frac{1}{2}$ "—Leg sides  
 1 pc.—1 $\frac{1}{4}$ "x4 $\frac{1}{2}$ "x21 $\frac{1}{2}$ "—Drawer front

### Lumber

- 1 pc.— $\frac{3}{4}$ "x5"x18 $\frac{1}{2}$ "—Top support  
 2 pcs.— $\frac{3}{4}$ "x1 $\frac{1}{4}$ "x23 $\frac{1}{2}$ "—Front and back rail, top cabinet frame  
 1 pc.— $\frac{3}{4}$ "x5"x17"—End rail, top cabinet frame  
 1 pc.— $\frac{3}{4}$ "x1 $\frac{1}{4}$ "x17"—End rail, top cabinet frame  
 2 pcs.—1"x1 $\frac{1}{4}$ "x23 $\frac{1}{2}$ "—Front and back rails, top cabinet frame  
 2 pcs.—1"x1 $\frac{1}{4}$ "x17"—End rail, bottom cabinet frame  
 4 pcs.— $\frac{3}{4}$ "x1 $\frac{1}{2}$ "x6 $\frac{3}{4}$ "—Cabinet posts  
 1 pc.— $\frac{3}{4}$ "x1"x16 $\frac{1}{2}$ "—Center drawer  
 2 pcs.— $\frac{7}{16}$ "x2-1/16"x15 $\frac{1}{2}$ "—Center drawer slide  
 1 pc.— $\frac{1}{2}$ "x3 $\frac{1}{2}$ "x21 $\frac{1}{2}$ "—Drawer back  
 2 pcs.— $\frac{1}{2}$ "x4 $\frac{1}{2}$ "x16 $\frac{1}{2}$ "—Drawer sides  
 4 pcs.—1 $\frac{1}{4}$ "x1 $\frac{1}{4}$ "x2 $\frac{1}{2}$ "—Leg corner blocks  
 1 Hanger bolt and nut,  $\frac{3}{4}$ "x2 $\frac{1}{2}$ "  
 1 Pipe,  $\frac{3}{8}$ "x3" long  
 1 Washer,  $\frac{3}{8}$ "  
 6 Furniture glides,  $\frac{3}{8}$ " dia.

Three-in-one functional design adapts readily to suit varied furniture arrangements. Features pivoted base containing roomy drawer

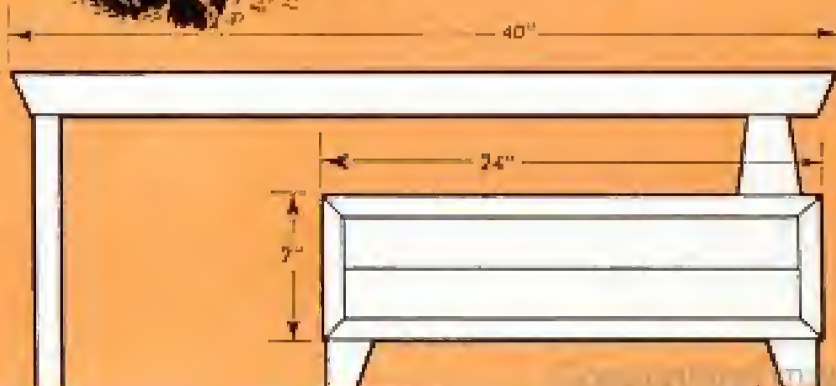
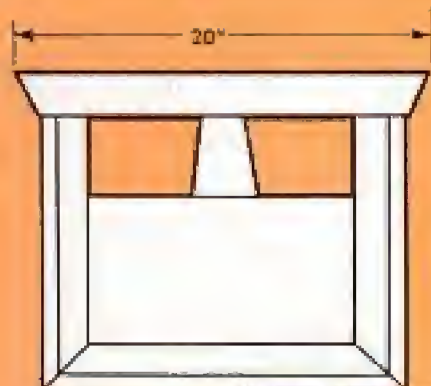

## Chrome-Plated Mats Protect Walls Against Grease Spatters and Stains



Photo by Phoenix Table Mat Co.

Protecting the walls behind the range from grease spatters and cooking stains, two of these new 17 x 19-in. chrome-plated mats are tacked to the wall to form a shield. The mats, which also insure stove tops and other fine surfaces complete protection from scratches, burns, stains and nicks, are made of heavy-gauge steel, chrome-plated over four undercoatings of copper and nickel. Their rounded corners prevent cuts and snags, and the asbestos-cushion backs protect surfaces against heat and sharp blows. Available in a wide variety of designs, including an old fashioned sampler design and floral pattern, the mats add brightness as well as practical durability to any kitchen. Matching 9-in. round hot pads may be used as unusual place-mats or as coasters under hot or iced drinks. A damp cloth or sponge occasionally wiped over the surface is all that is required to maintain the finish.

## Converting Vase Into Lamp Base Without Drilling for Pipe or Wire

Many small-neck vases and fancy bottles can be converted into beautiful lamp bases. The problem generally is how to attach the lamp socket to the top without drilling a hole in the bottom of the bottle for a pipe and locknut. Here's a way that works perfectly. Cut a hardwood strip about 1/2-in. square, just long enough to catch inside the vase shoulders. Insert a screw eye in the middle and solder another screw eye into a length of electrical pipe, making sure the pipe is long enough to allow sawing off after assembly. Spread one of the screw eyes and hook the block to the pipe, then insert the wooden strip into the vase. The vase is capped with a plastic or wooden disk which has a hole drilled in the center. This disk is now slipped over the pipe and held by a washer and locknut.

Art Trauffer, McClelland, Iowa.

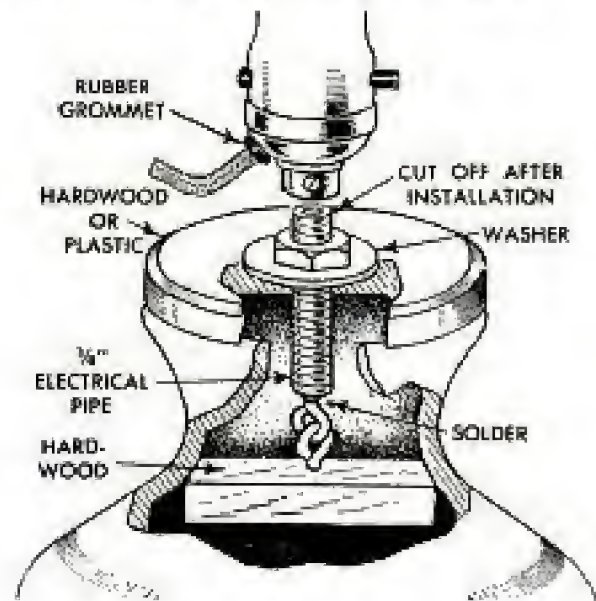

## Clothespin Used to Retrieve Articles in Inaccessible Locations



A spring-type clothespin tied to a yardstick can be utilized to retrieve small objects dropped into inaccessible locations, such as between the cooking range and the wall. After it is fastened to the end of the yardstick, the clothespin is tied open with a bowknot. A piece of cord about 4 ft. long is used. To retrieve an object, the open jaws of the clothespin are slipped over it and the bowknot is untied by pulling on the cord. The clothespin will clamp on the object allowing it to be lifted.



## AIR CONDITION YOUR DARKROOM



**INSTALLING** an air conditioner in your darkroom will solve several problems that are inherent in the operation of all photo-developing equipment. First, an air conditioner of the proper type will bring in fresh air and exhaust the stale air from the darkroom. Because the darkroom must be sealed against light, it is often almost airtight. No operator can work efficiently in a stuffy, airless location. An air conditioner will cool the room in hot weather. Besides the definite comfort provided to the operator, keeping the temperature down will also maintain a lower humidity. Some air conditioners have a built-in dehumidifier. The liquid developing solutions, water used for washing prints and even perspiration from the body tend to cause a condition of high humidity. This moist air is detrimental to sensitive chemicals and is definitely destructive to metal equipment and to the wooden structure and furnishings of the darkroom. If the air conditioner is equipped with filters, as most of them are, the resulting clean, dust-free air is an obvious advantage. The small, room-

size air conditioners are fairly reasonable in cost and will efficiently condition the air of the average home darkroom. Their cost is comparable to the price of other major pieces of darkroom equipment. Depending on the size of the darkroom and pocket-book, the units run from about \$250 to \$400. Their installation is simple because they do not require any plumbing connections. They are just plugged into any 110-volt outlet. If there is a blacked-out window in the darkroom, the air conditioner can be fitted into the window with a minimum of work. Once in place they are light tight. If no window is available, an opening in the wall will, of course, require some carpentry work. Another way of improving your darkroom, at less than the cost of an air conditioner, is to install a dehumidifier. Although it will not change the air of the room, nor cool it, the resulting dry air will protect the equipment. Dry air also seems cooler than moist, because body perspiration is absorbed more rapidly into the dry air, allowing the body to adapt itself to a higher temperature.



### Grooved Wooden Shoe Polisher Used as Sanding Block

A discarded shoeshine brush makes an excellent sandpaper block. Remove the old wool covering, cut deep grooves in the end of the wooden block and insert the ends of the sandpaper into them. Heavy wire wrapped around the block, or wooden strips wedged into the grooves, will hold the sandpaper in place. The padding under the wool is left on the block to cushion the sandpaper and make it last longer.

## Baby's Dressing Table and Chest Made From Secondhand Desk



This baby's chest of drawers, which features a chest-high dressing table, helped one young couple solve the space and storage problem in their small apartment. The chest, purchased at a secondhand store, was originally a drop-front desk. The drop-front writing surface was removed, new hardware was used on the drawers and the whole chest painted a color to match the decor of the room. A piece of  $\frac{3}{4}$ -in. plywood, 16 in. deep, and as wide as the chest, was screwed to the top for the dressing table. Then it was covered with quilted plastic to make a sanitary, easily cleaned surface. The open space under the top, and the inside of the drawers, was covered with a contrasting color of wallpaper which was sprayed with clear lacquer to make it washable.—Maurine M. Remenih, Arlington Heights, Ill.

## Cotton Packing in Bottles Removed by Wood Screw

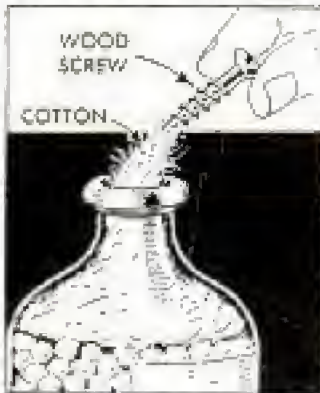

The hard-to-reach cotton wad often used in bottles containing pills and capsules to protect the medicine in transit, can be removed quickly and easily by means of a long slender wood screw. After uncapping the bottle,

twist the screw slowly into the cotton, allowing it to wind on the screw. Then gently pull the cotton wad out of the bottle.

John Edwin Hogg, Alhambra, Calif.

## Screening Frayed at Edges Nailed to New Support

I recently had the problem of repairing a number of screens where the copper screen wire was in good condition but pulled away or broken from the

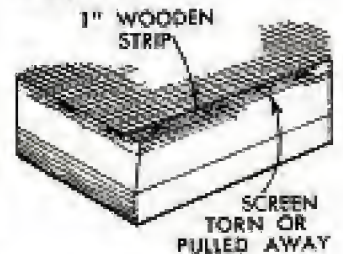

frames in some places, making it difficult to retack. I solved the problem by cutting 1-in. strips of wood, painting them beforehand, and then nailing them to the inside of the screen frame as new supports. By thus increasing the thickness of the frame, I was able to tack the screen wire in place, putting the tacks through the unfrayed portion. The appearance of the screen was almost unchanged by this alteration.

J. Howard Cooper, Philadelphia, Pa.

## Porcelain Cemented on Metal With Glycerin-Litharge Paste

A paste made from glycerin and litharge makes an excellent adhesive for attaching porcelain handles to metal fittings. The liquid glycerin can be purchased at a drugstore, while most paint stores carry litharge paste. Mix the glycerin with the litharge until a fairly heavy paste is made. Fill the depression in the porcelain handle about half full of the paste, then press it on the metal fitting. Wipe off the excess paste that oozes out. About 24 hours is required for the cement to harden.





Speedy express cruiser, shown above, is the ultimate in boat-kit building

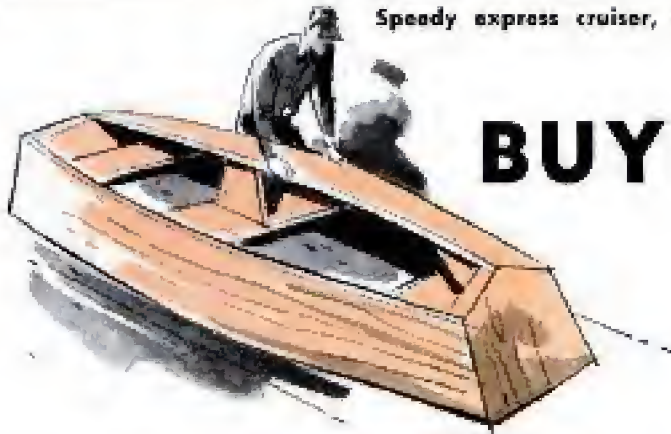

## BUY YOUR BOAT IN A PACKAGE

**E**VERY YEAR, more and more amateur boat builders are assembling a wide variety of craft from packaged boat kits. These kits, which are manufactured by some of the finest boat-building firms in the country, have been designed by top naval architects for easy construction by the average person. Full step-by-step instructions have been prepared for each kit, and all the difficult work of laying out and building the frames, stem and transom has been eliminated. The job is simplified to the point where the boat can be assembled with ordinary hand tools and requires no previous boat-building experience or technical knowledge.

In addition to simplicity, there are several reasons for the increasing popularity of these kits. For the man who wants a boat for his personal use, the kits afford a considerable savings over buying a completed craft and, of course, the pleasure and satisfaction of building his own boat. Also, with the improvement of outboard motors in recent years, he can get a reliable, high-performance outboard boat at comparatively low cost. The kits are an advantage to those who prefer a fairly large

boat, since a larger boat in kit form can be bought for the same amount of money ordinarily needed to purchase a smaller craft already assembled.

Most of the boats made from packaged kits are somewhat similar in construction. They consist primarily of marine-plywood bottoms and side panels laid over prefabricated frame sections. The advantages of marine plywood over standard planking are its light weight, fewer seams and the fact that no calking or swelling are necessary before the hull becomes watertight. The latter feature is important when the boat is carried around on the car top or trailer.

Packaged kits are available for rowboats in sizes from 8 to 14 ft., for outboards from 12 to 21 ft. in length and for inboards from 16 to 31 ft. Specialty boats, such as hydroplanes, duck boats, prams and kayaks also are available in kit form. The kits may be purchased directly from the manufacturer, mail-order dealers and from local marine-supply dealers.

The standard kit includes fully assembled frames, which are notched and beveled to fit the curvature of the planking, fully

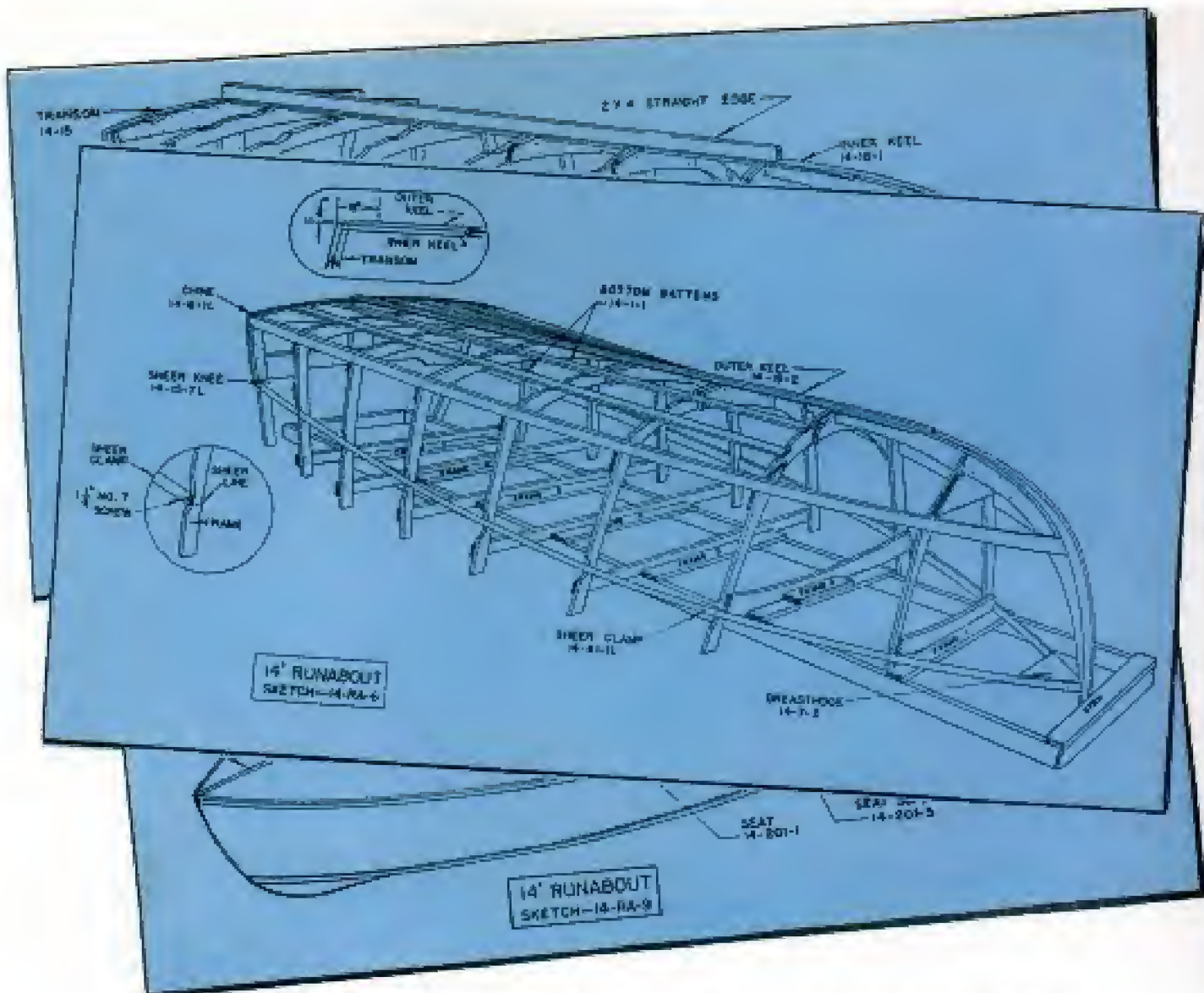

Sample plans, above, give you an idea of the detailed assembly instructions that accompany the boat kits. These, together with pre-cut and prefabricated parts, mean surprisingly easy construction

Assembled quickly from packaged kits, the skiffs shown below are ideal for the fisherman. They are available in 12 and 14-ft. lengths and combine sturdiness with light weight for easy transporting



assembled transoms, formed and shaped stems, all lumber needed, marine plywood, marine glue, bedding compound, screws and nails. The plywood parts are cut to shape a little oversize to allow for trimming. Some manufacturers require a mold board for building the boat. This can be made or purchased extra. Other firms include a building platform, when necessary, while still others require neither a building platform nor a mold board in assembling their boats. Normally, the only extra material that must be purchased is trim hardware, motor and, in some cases, paint. Oarlocks are furnished for rowboats.

The man with the necessary know-how can make the same 40 to 60-percent savings that the kits offer by building his boat from stock plans. However, it often is difficult to obtain locally the lumber and plywood necessary. Many boat builders have run into trouble because of difficulty in obtaining air-dried lumber of the size and variety needed without buying more material than necessary and, possibly, paying extra for having the lumber cut to size. Purchasing the packaged kit saves the time and effort necessary in shopping for the right material and the added expense of getting the right boat material cut to the proper sizes.

In order to get the most satisfaction from boating, selecting just the right boat is as important as the care used in building the



Whether it's for fishing or "water taxi" service, you'll find this little prom most useful of boats

craft. If you've decided that you're in the market for a boat, obtain catalogues from several firms and try to select a boat that fits your requirements as closely as possible. Outside of personal tastes, there are two main things to keep in mind in deciding on the boat you want—the uses to which you intend to put the craft and the type of water on which the boating will be done. On protected waters, an open boat often will serve the purpose, but if you're heading out on open water you'll want a larger, sturdier craft with a forward deck. If you know on which body of water you intend to do your boating, observe the type of

Except for the hand tools, here's what you get with the typical boat kit. Completed boat is in the background

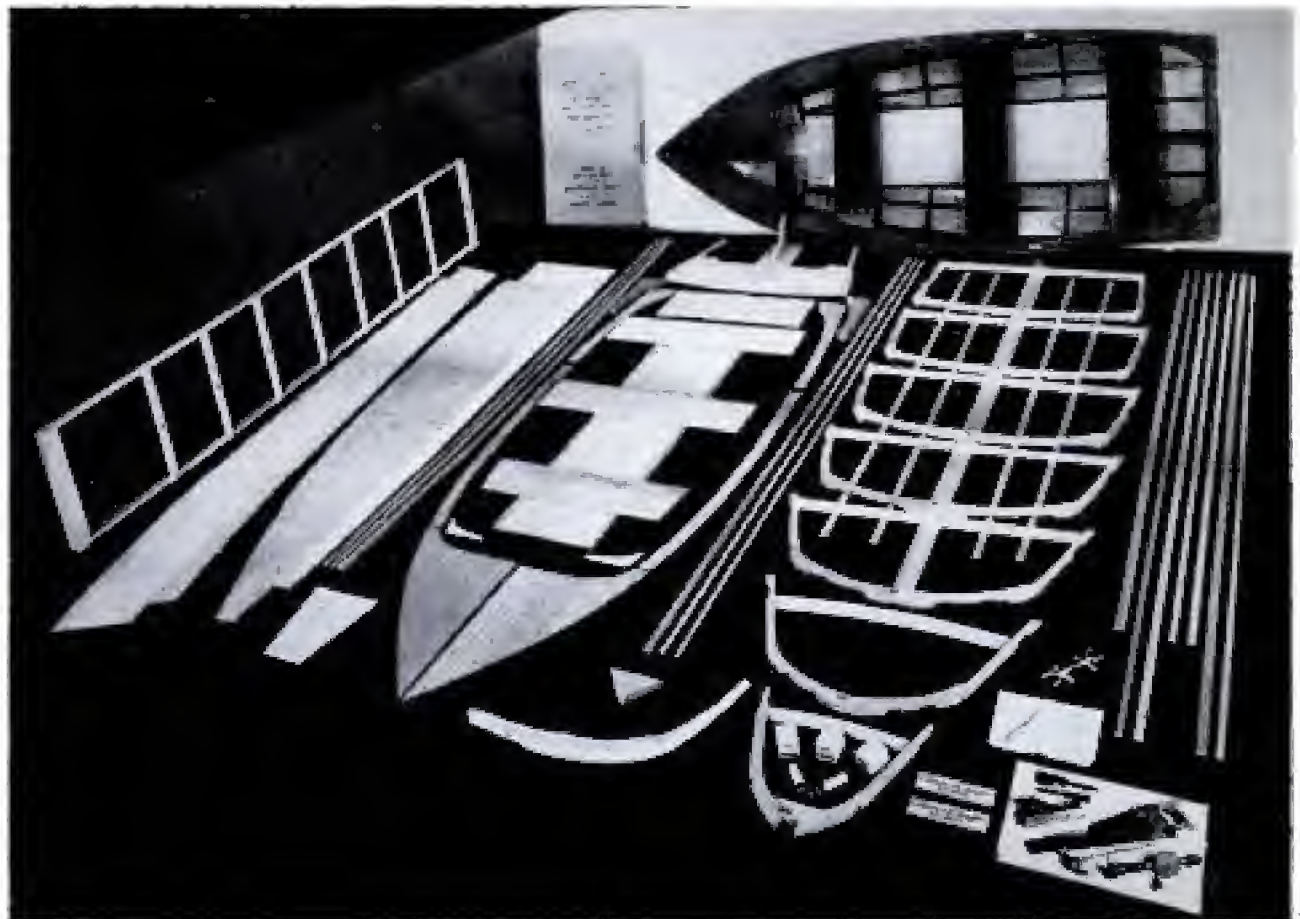

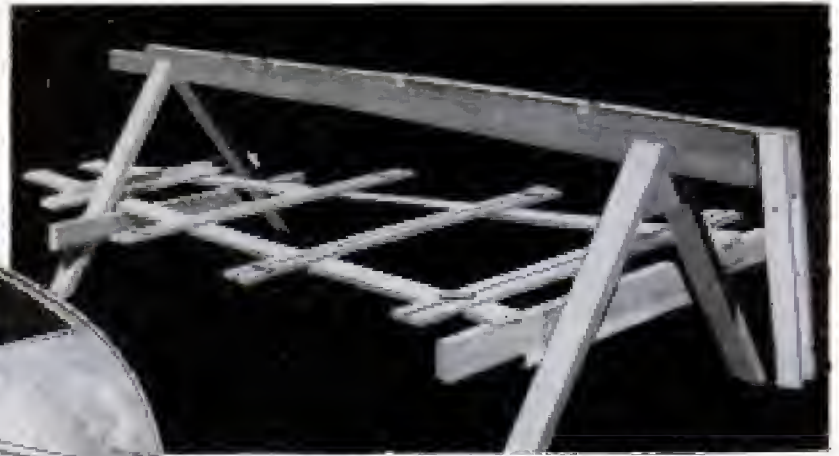

Boat is assembled upside down with a mold board being used in some cases. Mold board is raised on horses, above, so tops of boat frames clear floor

craft used in that particular locality.

When a boat is kept in or near the water during the greater part of the boating season, its size and weight are of little importance. However, if the boat must be hauled to and from the water, its size and weight become well worth considering. For car-top carrying, one person can handle a boat that is no more than 12 ft. long and weighs less than 125 lb. Two people are able to handle a boat weighing up to 145 lb. Boats over 14 ft. long and heavier than 145 lb. should be carried on a small trailer. In most states, speedboats and cruisers 18 ft. long, 7 ft. wide and weighing less than 1800 lb. can be carried on car-towed trailers. However, it is best to check state regulations before attempting to haul boats larger than these dimensions.

The fisherman who likes to go out alone in protected water usually can get by with a 10-ft. open rowboat. However, if he takes passengers along with him, the boat should be larger in proportion to the number of people to be carried. On open water, the lone individual would require a minimum-

sized boat of 12 ft. with a closed forward deck. For speed or water sports, such as aquaplaning or skiing, the boat should be one with a closed forward and center deck and large enough to take an outboard motor of 10 hp. or more. Of course, an inboard boat can be used, but in either case, the hull should be of the round or V-bottom planing type.

Before selecting an inboard or outboard boat for competitive racing, it is best to obtain the rules and regulations from the American Power Boat Association, 700 Canton Ave., Detroit, Mich.

A 16 or 18-ft. outboard cabin cruiser is ideal for those who do not live near the water but enjoy weekend cruising. These boats are carried easily on a small trailer and may later be converted to inboards if desired. Where the boat can be kept in the water the greater part of the boating season, an inboard cruiser over 18 ft. in length should be considered, as this type of craft offers more stability and greater cruising range than the smaller boats.

When possible, it is better to purchase

Speeds above 35 m.p.h. are possible with this 8-ft. pram. Boat takes outboard up to 7½ hp.



a boat that is larger than you believe you might need than a boat that is liable to be too small and unsafe for the purpose. Also, it is important to match your outboard motor to the boat. Outboards of less than 3½ hp. should be used on boats under 10 ft. in length and only in sheltered water. For fishing, an outboard motor of 5 to 10 hp. on a 12 to 16-ft. boat is excellent. Speedboats and hydroplanes should have outboard motors of 10 hp. or more and outboard cruisers should carry a 25-hp. motor or a pair of twin 25's.

The tools necessary for building a boat from a package kit include a hammer, drill, saw, brace and countersink, rasp, screwdriver and hand plane. A portable electric drill will do wonders to speed the work. In many cases, clamps will prove helpful.

As the frames, stem and transom of the packaged boat are shaped and machined to size, it is unnecessary to lay out the boat in full-size plan and elevation. When a mold board is used in building the boat, the board should be laid out carefully and cut to shape. Then it is mounted on horses so the frames will clear the floor. If a building platform is used, it should be leveled with wooden wedges nailed both to the floor and the building platform to prevent slippage. In cases where neither a mold board nor a building platform is used, and the frame tops are placed directly on the shop floor, it is necessary to check the floor for level. If the floor is not level, blocks must be tacked to the tops of the frames to bring each frame level with the other frames. The complete assembly instructions furnished with the kit should be followed carefully. Clamps and chines of the boat should be put on both sides of the frame temporarily and the frames checked for squareness to the keel before final fastening. The clamps and chines can be tied in place while checking the frames.

As most boat kits utilize fir plywood, a fir sealer should be applied to prevent hairline checks from occurring in the coats of paint. For boats used in salt water, all fittings should be brass and the bottoms of the boats coated with antifouling paint. ★ ★ ★

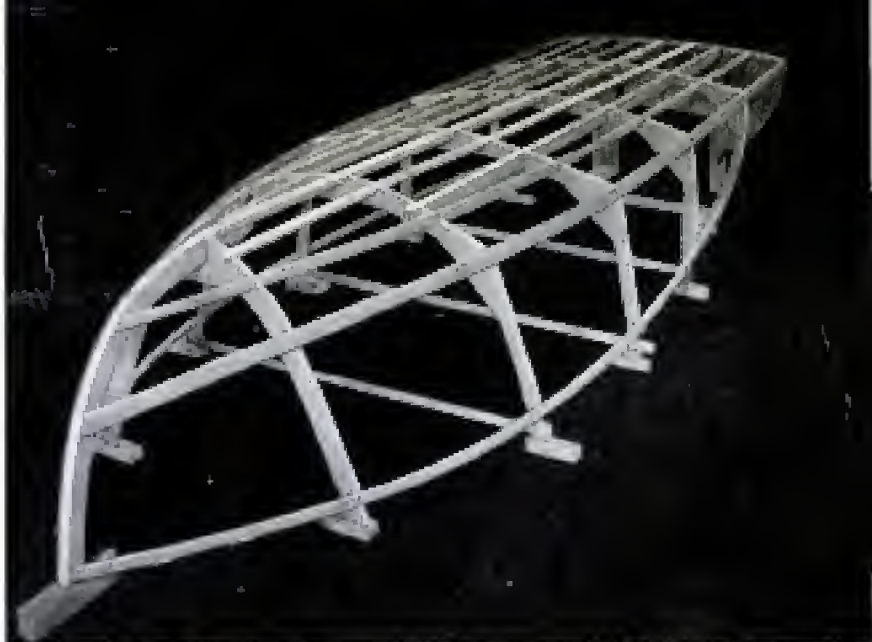

Some boat kits are assembled directly on floor. Unless floor is level, frames and stem must be leveled with blocks, above



Inboard cruiser, above, is fine boat for family cruising and fishing on open water. Note that the outboard utility boat below has a planing-type hull which skims on top of the water



Photo below shows outboard runabout in final assembly stage with the forward and center deck panels being applied





### Baseboard Light in Clothes Closet Aids Selection of Garments

Installing a wall outlet at the rear of a clothes closet just above the baseboard permits you to illuminate the lower portion of the closet to help in selecting clothes. Use an ordinary night light or a plug-in adapter along with a low-wattage bulb. The light will be more convenient if it is wired to a wall or door-actuated switch.

Jerry Dunham, Chicago.

### Phonograph Needle Protected By Cellulose Sponge on Arm



A cellulose sponge will prevent damage to the permanent needle on a phonograph while it is being carried to a repair shop for service, or when packed for shipping. Wrap the sponge tightly around the pick-

up end of the arm and hold it in place with a rubber band. Be careful when removing sponge not to catch the needle point in it.

Hugh Lineback, Stillwater, Okla.

### *Common Sense Afloat!*

If you are one of the thousands who will take to outboard boating next summer, you'll be eager to read the two-part story beginning next month which tells you how to care for, select and handle your outboard motor for the most fun and safety

### Lawn Seeder Containing Sand Used to Treat Icy Sidewalks

Instead of storing my lawn seeder for the winter, I use it for spreading sand, salt or sawdust over icy sidewalks and driveways. The implement does the job evenly, while a control lever permits the flow to be regulated when passing between patches of ice. It permits an even distribution that is not otherwise possible.

Fred Lettino, Astoria, Long Island, N. Y.

### Cupboard Latch Improvised From Spring Clothespin

A simple yet effective latch for cupboard doors can be made from a spring-type clothespin and a screw hook. Disassemble the clothespin by sliding it apart, drill two small holes in the half with the spring still attached, and then fasten this half to the inside of the cabinet with small wood screws. Reassemble the clothespin, and drive the screw hook in the door, with the hook portion turned so that it is flat when engaging the jaws of the clothespin.

Robert E. Damm, Englewood, Colo.

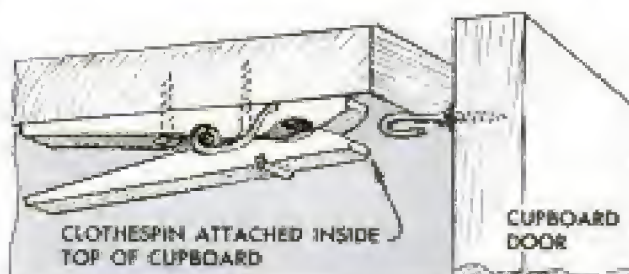

### Utilizing Old Paintbrushes As Glue Applicators

When a paintbrush has been discarded because of hardened paint near the ferrule, there will still be enough free bristles to make small brushes. Remove the bristle part from the ferrule and cut it into a number of small sections. Cement, tie or tape the sections to small wooden handles. The resulting brushes can be used for glue, paint remover and other liquids, then discarded.—Ken Murray, Colon, Mich.





# LIGHTNIN' BUG NIGHT LIGHT

By Kenneth M. Doolittle

FIREFLIES always fascinate children and this giant captive of the species is no exception. The steady blinking of this colorful electronic pet in a child's bedroom seems to help bring on the sandman. The basis of the bug's operation is a small oscillator of very low frequency. The tiny neon bulb serves the dual purpose of the bug's light and as a control for the oscillator. The current consumed by the bulb is so minute that there is hardly a measurable drain on the battery, so the bug may be left on continuously and still run many months. However, a switch may be installed to turn him off during the day if you so desire. To protect the battery, the bug must be kept away from heat and kept dry.

The base of the bug, a wooden box  $2\frac{3}{4}$  x  $4\frac{1}{4}$  x 6-in., contains the battery, condenser and resistor. The bug stands permanently on this box on legs made from No. 20 solid-copper wire. The shape of the bug's head and body is not important, but should have a resemblance to the real thing. They are made from balsa or some other easily worked wood, while the wings are cut from a tin can. A small hole is made in the tip of the tail to take the base of the



neon bulb. The two wires of the bulb are brought forward along the bottom of the body and soldered to the rear legs at the point where they join the body. The front and middle legs are cemented in holes in the top of the box, while the rear legs pass through the top to the interior, where they are connected into the battery circuit as shown. Paint the bug in bright colors. The one pictured was painted bright yellow and decorated with red stripes and dots while the box was left a natural wood color.

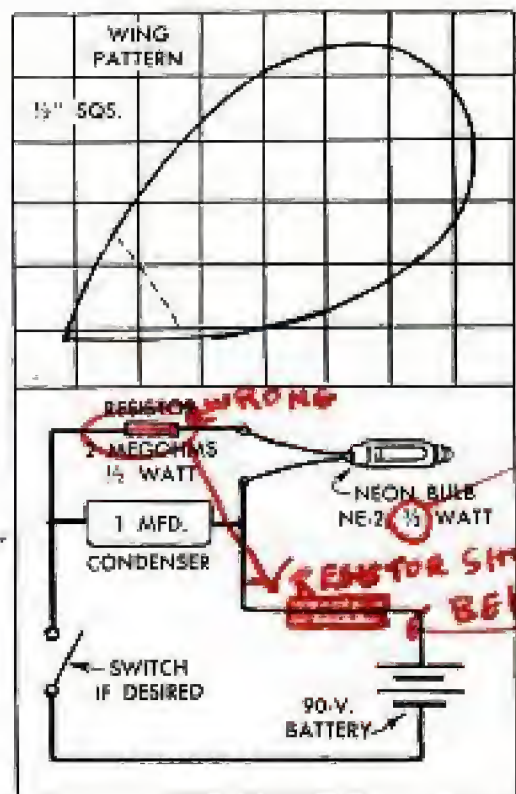
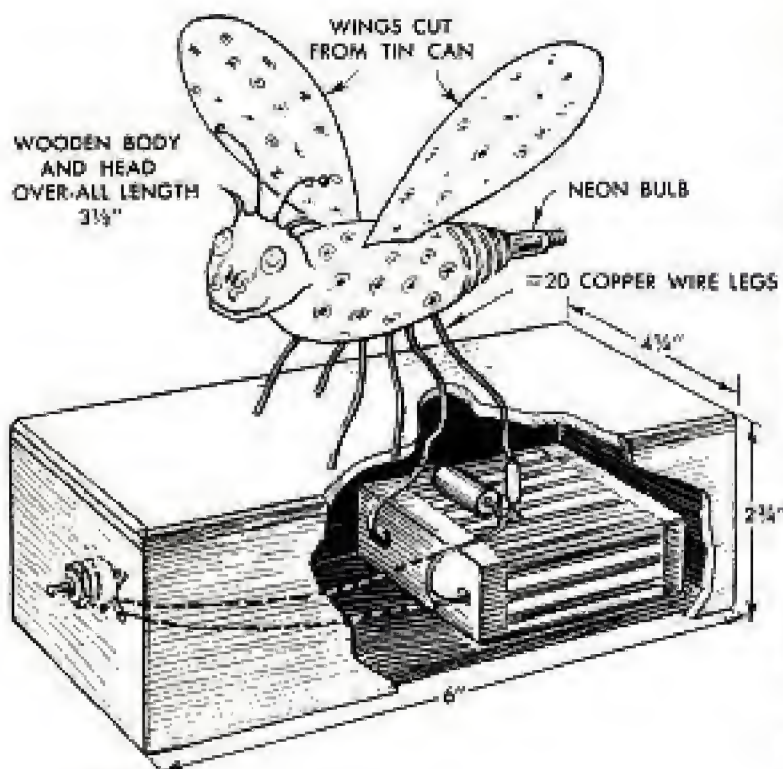

# TRY YOUR HAND AT MODELING THE MIDWAY

By Paul Strayer

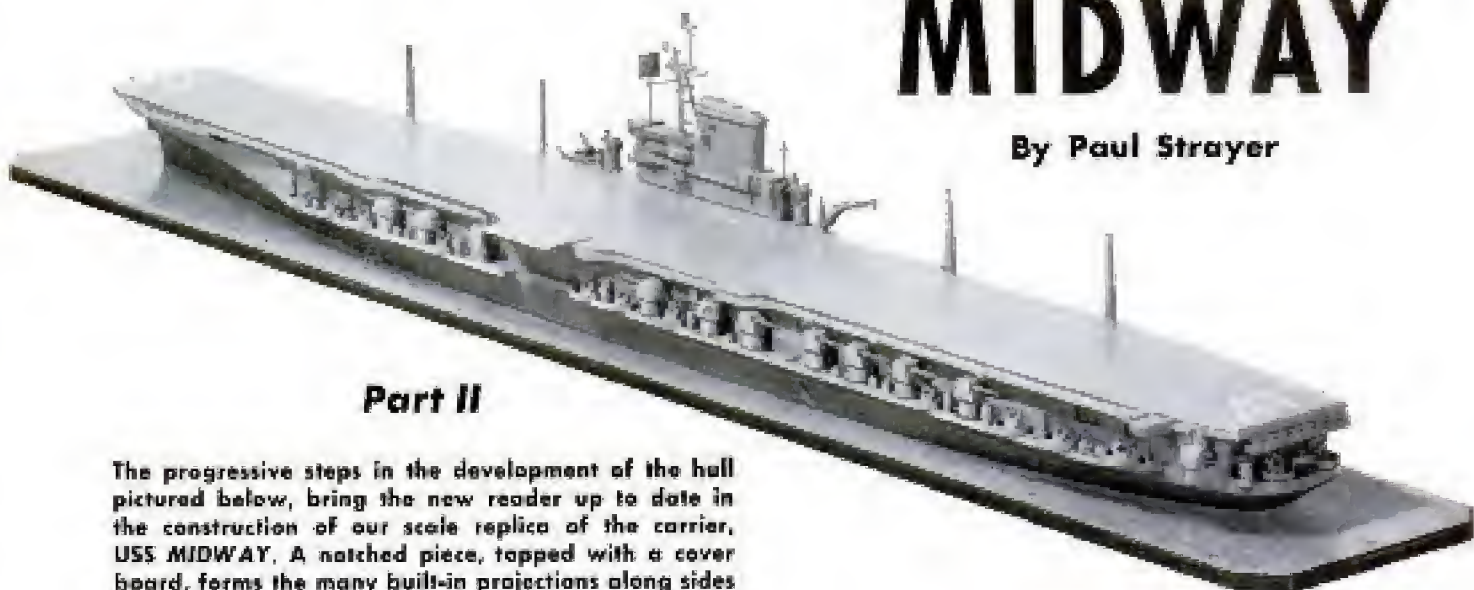

## Part II

The progressive steps in the development of the hull pictured below, bring the new reader up to date in the construction of our scale replica of the carrier, USS MIDWAY. A notched piece, topped with a cover board, forms the many built-in projections along sides

### DEVELOPMENT OF HULL

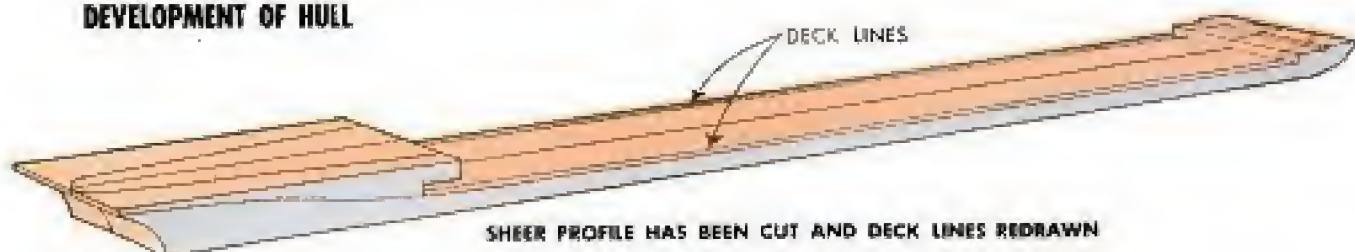

SHEER PROFILE HAS BEEN CUT AND DECK LINES REDRAWN

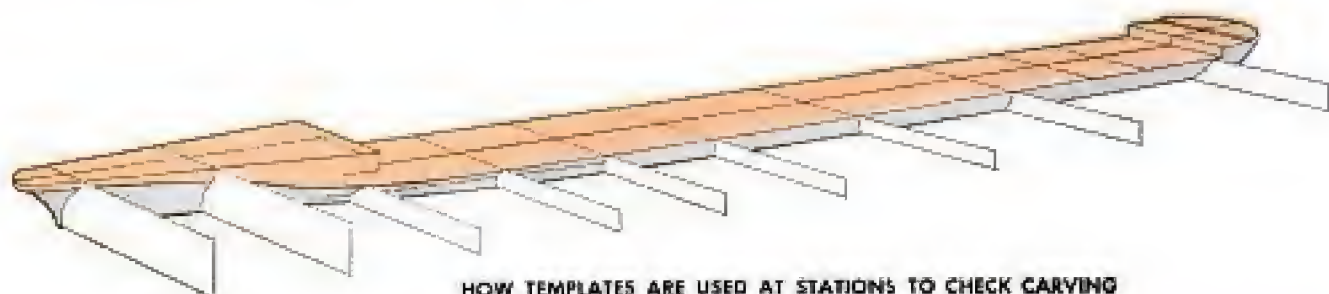

HOW TEMPLATES ARE USED AT STATIONS TO CHECK CARVING



THIS IS HOW YOUR HULL SHOULD LOOK WHEN CARVED

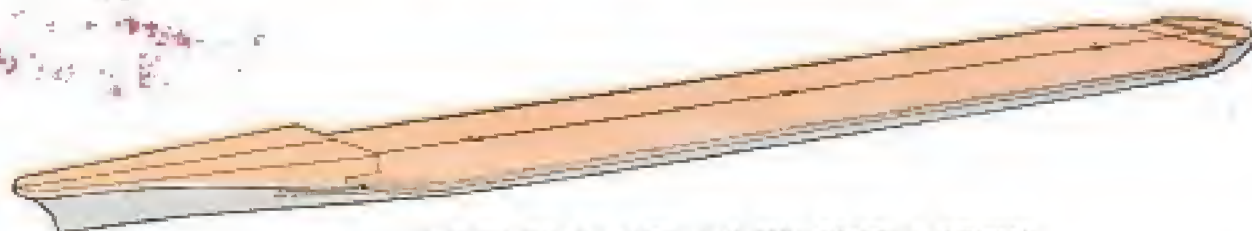

HERE THE SPONSON PIECE HAS BEEN ADDED TO THE HULL

**L**AST MONTH you were told how to lay out and carve the hull for your scale model of the mighty USS *Midway*. This covered sawing the sheer profile and deck lines, carving the sleek lines of the hull, fitting the sponson and cutting the notched piece and cover board. The progressive steps pictured on the opposite page serve to orient new readers on what has gone before.

**The island base:** Before getting into the actual superstructure of the *Midway*, your next step is to install the projection, or base, on which the "island" rests. Located on the starboard side of the ship, the projection rests on the overhanging ledge provided by the sponson, and is brought flush with the edge of the sponson and the surface of a hull lift, called the gallery piece, yet to be fitted. The general shape of the projection piece is shown in the perspective drawing at the right. It measures 5 3/4 in. long, but the actual shape of it is more easily taken directly from the full-size plans which are available. You'll note in the drawing at the right, that there are a series of tiny platforms fitted to the face of the projection piece. The six small platforms spaced along the upper edge of the projection piece are glued in shallow mortises, or slots, the platforms projecting 1/8 in. Below these platforms is located a 3/16-in.-thick shelf which, in turn, rests on a slightly thicker one immediately below it. The latter is scored vertically with a knife blade at 1/4-in. intervals to represent life-saving equipment. Note the deep recesses

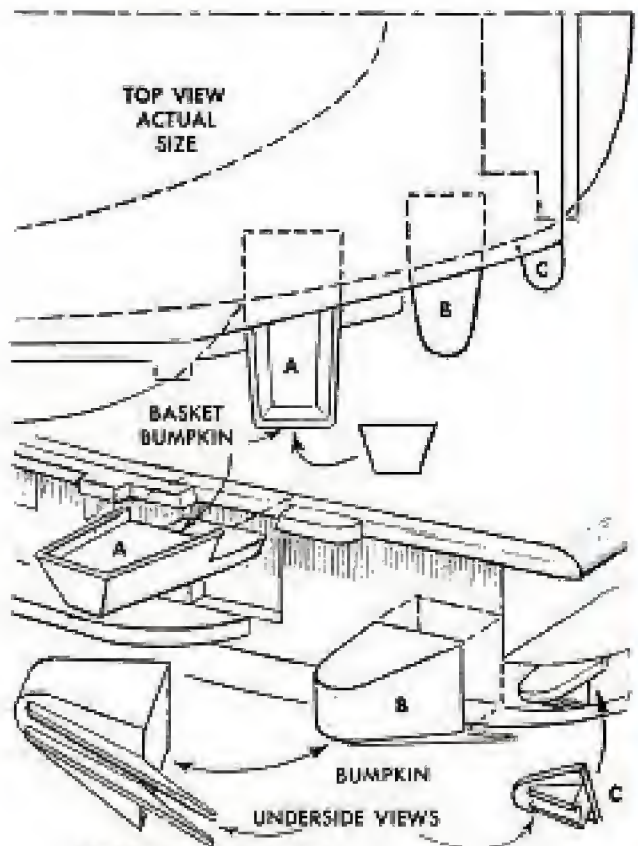

FEBRUARY 1954

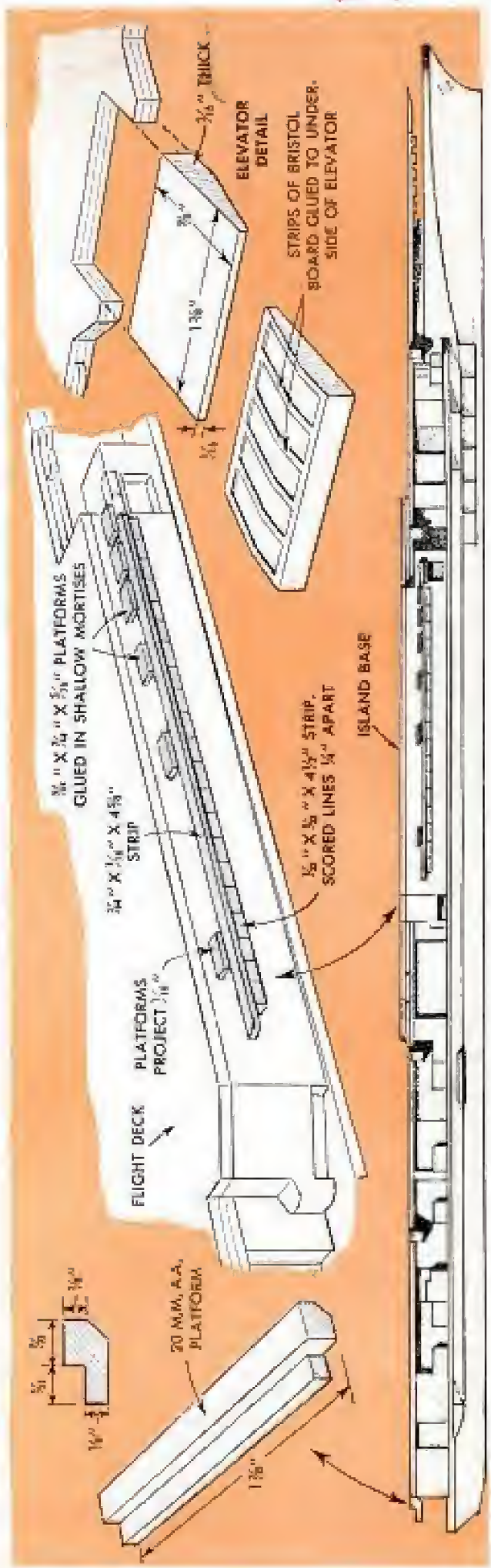

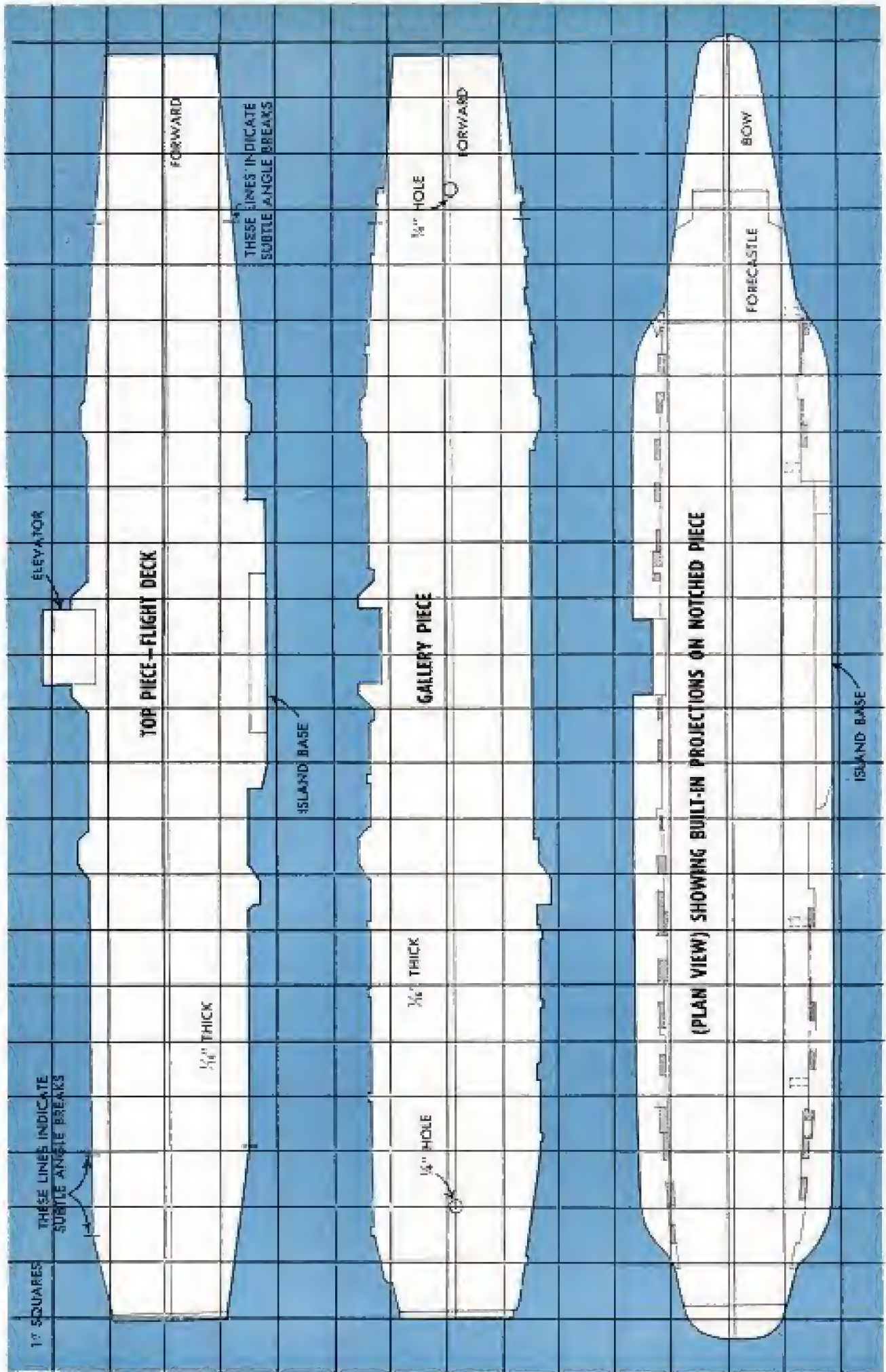

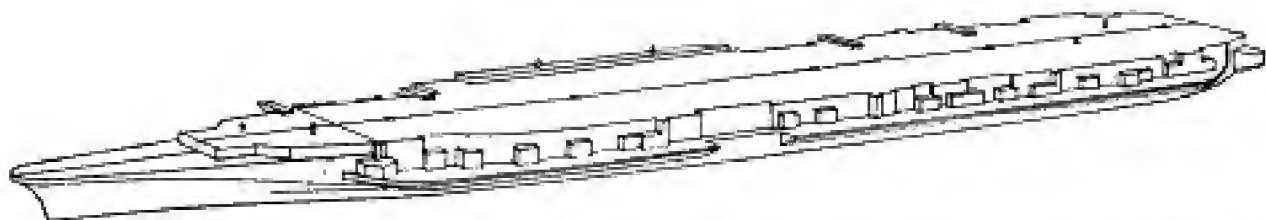

Portside view of hull shows sponson, notched piece, island base, forecastle, tower bases and stern bumpkins

fore and aft in the projection piece. These are cut before the block is glued in place.

**The deck assembly:** The deck assembly consists of three parts, namely, the cover board, described in Part I, the gallery piece and the flight deck proper. Patterns for the gallery piece and the flight deck are given on page 214. Unless you are working with full-size plans, these patterns will have to be enlarged to the proper size on 1-in. squares. The gallery piece, which is placed on top of the cover board, is cut from a piece of clear white pine,  $\frac{1}{8}$  x 4 x 24 in. Mark a centerline completely around it, top, ends and bottom, and drill a  $\frac{1}{4}$ -in. hole at a point 3 in. from each end. These holes serve as "peepholes" to let you see the centerline drawn on the cover-board piece when centering the gallery on top of it. Dowels are used as before to register the gallery on the cover board. These are driven into holes drilled  $\frac{1}{8}$  in. deep in the cover board and sanded off flush with the surface of the gallery piece. Use a jigsaw or a sharp knife to carefully cut the thin gallery piece to shape. It is important that the edges be finished squarely. The flight deck is also made from  $\frac{1}{8}$ -in.-thick pine. You'll note in looking at its pattern that the particular shape of the flight deck is such that it overlaps the top of the island base. In placing it in position on top of the gallery piece, be sure that it is centered so that an even margin is maintained along both sides of the flight deck. Here again, a registering dowel at each end of the flight deck is used to position the piece.

Now you are ready to glue the three members together, the cover board, gallery and flight deck. Use a slow-setting adhesive and clamp the pieces together, taking care that the surface of the flight deck is protected from clamp marks with a scrap of wood. Let the glued-up assembly dry for at least 24 hr. Wipe away any excess glue

along the joints at the edges. After the glue has dried, the ends of the built-up piece are shaped according to the profile view. A small upward-curving recess,  $\frac{1}{8}$  in. deep, is carved on each side at the very forward end of the flight deck. Make sure that the recess for the elevator on the port side of the ship registers exactly with the door of the hanger deck below it, and that the sponson piece is recessed to align exactly with both the door and the elevator.

Your model now consists of two separate units, the top assembly being held to the bottom assembly by the small snug-fitting registering dowels previously installed. This permits the flight-deck assembly to be lifted off whenever you wish and thus makes it easy to install the various fittings along the sponson.

**The elevator:** The elevator fits in place flush with the flight deck. The detail on page 213 gives the size and shape of it, and shows how reinforcing ribs are represented by gluing tiny strips of Bristol board to the underside. After the elevator is glued in the recess provided for it, a line is scribed around it with an awl or a phonograph needle held in a pin vise to form a separation line. This makes the elevator appear as if it operates.

Next, a platform for 20-mm. A.A. guns is fitted to the aft end of the flight deck. The size and shape of this piece is detailed on page 213. This platform butts against the end of the cover board and is glued to the underside of the overhang of the flight deck. On the port side, aft, three bumpkins are glued in place as shown in the details

#### FULL-SIZE PATTERNS

Actual-size patterns of the various lifts that comprise the hull of the *Midway*, as well as patterns for the fittings, are available for tracing directly on your wood to simplify construction of your model. A set of five sheets, at \$2.50 per set, may be had by sending your remittance to our blueprint department.

This view is from the starboard side which shows the island base in place. Note the registering dowels

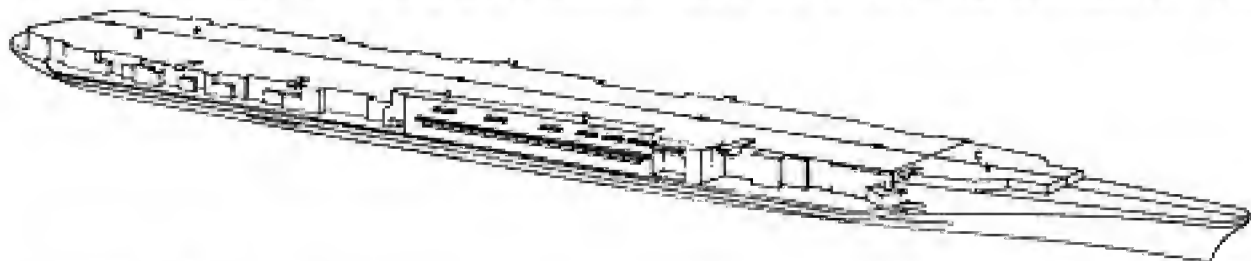



Here's what your model should look like at this point of construction. Hull now consists of two separate units

at the bottom of page 213. Bumpkins B and C support range finders which are to be described later. The plan view shows these parts actual size for tracing. You'll note that the basket bumpkin is rabbeted to fit a notch cut in the edge of the gallery piece and extends back under the overhanging deck. Use bits of hardwood to make these parts and work them to shape with a fine file. The supporting ribs on the underside of bumpkin B are faired into the lines of the hull with a file after they have been glued in position.

In addition to the many built-in projections formed by the notched piece, there are others that are glued on separately. These are tiny little blocks that are half the height of the projections formed by the notched piece, and a plan view to be presented in Part III shows where these are located in relation to the projections.

Next month you will be shown how the island superstructure is built up and how the various individual deck fittings and gun emplacements are simulated from bits of wood and brass. ★ ★ ★

## Popular Mechanics Bookshop

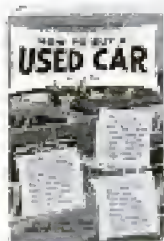

### Used Cars

**MOST OF US**, when we approach a used-car lot, feel helpless. We don't know much about checking used cars, so we find ourselves at the mercy of the salesman. *How to Buy a Used Car*, written by C. E. Packer, one of America's top automotive authorities, can save you many times its price on your first purchase. It tells you what to look for in a used car and how to check a car before you invest your money. On sale at your newsstand. The price is 75 cents



### Ideas for Boys

**BETWEEN** the covers of this book are literally hundreds of things for boys to make—kites, paddle boards, jet-power planes, model tractors, dart games and many other exciting projects. *The Boy Mechanic*, illustrated with hundreds of photos and easy-to-read plans, will thrill any boy, for here are projects that are not only fun to make but fun to play with afterward. Included is information on many exciting crafts that will provide hours of entertainment. The price is only \$2.95



### Paging Casey Jones

**HERE'S ANOTHER** *Popular Mechanics* picture history—the *Railroad Album*. Puffing through the pages of this book are all the famous locomotives of America, from the Tam Thumb of 1830 to today's honking streamliners. There's a fascinating peek, too, at the trains of tomorrow. The book is illustrated with more than 80 full pages of pictures of ancient and modern railroad equipment. Here's the book for any modern Casey Jones of the armchair or working variety. The price, \$3.00

All books available from Popular Mechanics Book Department, 208 E. Ontario St., Chicago 11



# SHOP NOTES

SN 56

## New Uses for DISK CEMENT

By Kenneth Murray

UNLIKE MOST ADHESIVES which harden on drying, cement supplied in stick form for attaching abrasives to sanding disks has the unusual property of remaining tacky for an indefinite period. This quality of stick adhesive can be utilized in a number of ways in the home and shop. The accompanying photos suggest eight ways the cement can be used for purposes other than that for which it was intended. For example, it will hold thin sheet-metal strips or squares together for jig-sawing in duplicate. Simply warm the pieces, coat



Disk cement will hold thin squares of sheet metal when stacked for jigsawing duplicate patterns. Warm the metal and apply cement to the edges as shown



Above, applying cement to the threads of a wood screw eases it into hardwood and at the same time adds to the holding power of the screw. Below, cement applied to face of miter gauge prevents stock from slipping sidewise when making miter cut



Above, use cement to prevent slipping of either flat or V-belts. Apply to the sides of a V-belt as indicated. Below, loose tires on bandsaw wheels are easily recemented in place by applying cement diluted with alcohol. Remove excess cement with turpentine





Screws often become loose and will no longer hold fine adjustment. Apply cement diluted with light oil



Gummed labels will not stick to bare metal for long. Apply them with disk cement and they'll stay put



In an emergency you can improvise a good electrical insulating tape by coating a cloth strip with cement

with cement and then press the pieces tightly together. Coating the threads of wood screws with cement eases them into hardwood and at the same time adds to their holding power. It also will prevent any type of belt, flat, round or V-type, from slipping. In each case, simply apply the cement to the glazed sides. Only a small amount is required.

When cutting grooves and especially miters, trouble is sometimes experienced with the stock sliding sidewise when held

against the miter gauge. A thin coating of disk cement applied to the face of the gauge will hold the work securely in place. The cement is removed easily from the stock with turpentine. It's a good idea to examine the rubber tires on the wheels of your bandsaw occasionally and if a tire, or band, is loose at any point on the wheel rim, it should be recemented immediately. Disk cement is just the thing for this job. Dip a small brush in alcohol, pick up a small quantity of the cement from the stick and apply to the wheel rim under the band. Wipe off any excess cement from the rim with a cloth dipped in turpentine.

Slow-motion screws, such as those on a thermostat, sometimes become loose and fail to hold a fine adjustment. Disk cement diluted with light oil and applied to the threads creates just sufficient "drag" to permit the required adjustment to be made. Note the procedure pictured in the upper left-hand photo. Ordinary gummed labels frequently loosen and drop from metal surfaces. To assure that the labels will stay in place indefinitely, use softened disk cement as the adhesive, applying it as in the right-hand photo above. In an emergency, a good electrical insulating tape can be made by coating closely woven cloth with disk cement. Heat the cement and cloth as in the lower left-hand photo and apply the softened cement to only one side of the cloth. ★ ★ ★

## Threading Holes in Plastics With Regular Metal-Cutting Taps

It is possible to thread holes in plastics with regular metal-cutting taps, but coarse threads should be used whenever possible. The plastic is easily fractured when cut to a thin section, as is the case when cutting a fine or S.A.E. thread. Where there is to be considerable wear, shock or stress, special inserts are available. A mild soap solution makes a good lubricant when hand tapping.

When machine threading, it is recommended that the tap or die be operated at 25% slower speed than is used for brass or aluminum. Taps should be backed out frequently and the excess material removed to avoid jamming. The work should be constantly flooded with lubricant when it is being machine-threaded.

L. E. Abell, Columbus, Ohio.



# Insert "Washers" Make Adjustable Wobble Saw

Grooves of varying width are cut easily with an ordinary circular saw blade by placing insert washers on the arbor, one on each side of the blade, to incline it at an angle with the arbor as in the detail. The washers are shaped like a staple from heavy wire (about  $\frac{1}{16}$  in. in dia.), each having a rubber band or a length of rubber tubing looped tightly over the ends as pictured. To assemble for use, remove the blade and slip one of the washers over the arbor with the rubber winding down. Replace the blade and slip the second washer over the arbor with the rubber winding up. Then replace the regular arbor washer and run up the nut finger-tight, making sure that the insert washers are in the correct position. Tighten the nut lightly and turn the blade

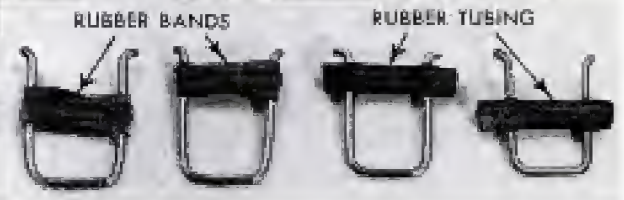
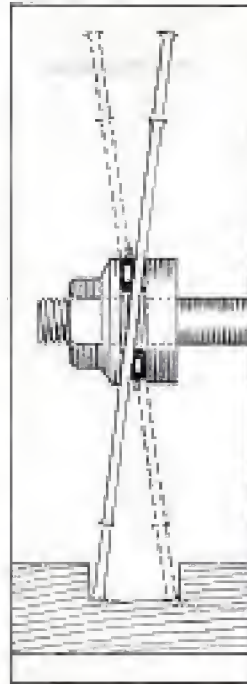

by hand. The extent of the wobble in the blade will be the width of the groove cut. This width can be varied simply by tightening or loosening the arbor nut.

## Heated Steel Plate Used to Temper Small Coil Springs

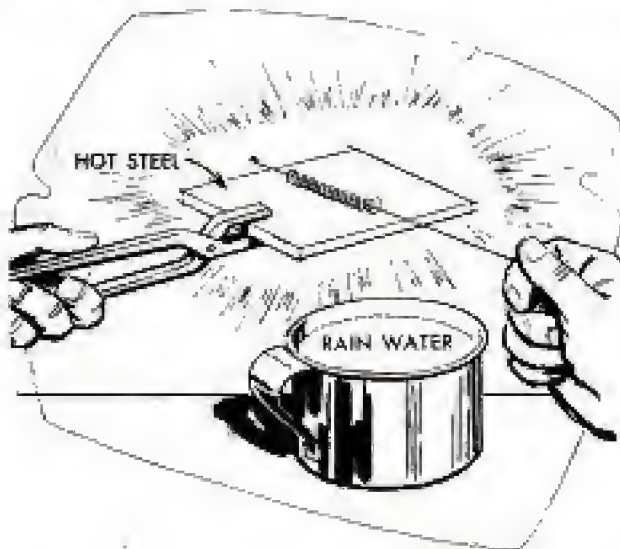

The difficulty of tempering small coil springs, which burn away when heat is applied in the usual manner, can be overcome by using a piece of  $\frac{1}{4}$ -in. steel plate. Heat a 3 x 4 in. piece of plate until it is red-hot, then allow it to cool until the red disappears. Holding the spring on a piece of wire that allows it to turn freely, lay it on the hot steel and roll it until the colors start to run. First will come yellow straw, then dark straw, spotted purple and finally the temper color of blue. The instant the blue shows, quench the spring in a container of rain water. If there is no rain or distilled water available, tap water may be used. The steel wire in the spring must be clean and shiny to show the colors.

E. J. Gilkerson, Columbus, Ohio.

## Chamois Washed in Machine Cuts Cost and Labor

When a service station operator needed a new tub and wringer for the chamois skins used for car washing and polishing, he bought an old trade-in electric washing machine from a near by appliance dealer. The washer, though old, was in working condition. In the morning before business begins for the day, the chamois are thoroughly washed in the machine in a car-

wash soapsuds solution. The washing machine is then drained and the tub filled with clear water. The rest of the day, as they are used to dry the washed cars, the chamois are rinsed in the clear water and run through the powered ringer. Besides saving time and labor, the machine-washed chamois last much longer than before.

W. C. Vanderwerth, Norman, Okla.

WTM '55

# SELF FEEDER GIVES SHELTER AND STORAGE SPACE

By  
George Laycock



TO ASSURE a constant supply of feed for hogs on distant pasture, one farmer built this permanent structure which combines a shelter, storage bin and self-feeder in one unit. Ear corn, whole grain or concentrates can be fed separately or in any mixture desired. A concrete slab, with offsets as in the floor plan, provides a foundation for the entire structure, and a dry feeding floor that prevents waste. The shed, or lean-to roof housing the self-feeder, is supported on 6 x 6 x 48-in. uprights angle-braced to 4 x 6-in. plates. The lower ends of the uprights are pinned to 4 x 6-in. sills bolted to the foundation. The floor of the storage bin extends to the hopper of the self-feeder as in the cutaway detail below. The height of the bin structure above the floor should

be at least 6 ft. at the eaves to give head-room. Of course, the roof can be made higher at the eaves and the bin space partitioned if desired.

Note that the full-height door to the bin is protected with a canopy and that a second smaller door closes the opening into the bin through which the feed supply is shoveled from a wagon or trailer. If desired this opening can be cut in the adjacent wall of the bin. When cattle are run in the same lot, the lower portion of the structure can be enclosed with woven-wire fencing and a sliding door fitted to form a creep admitting only hogs. As pictured, the original structure was covered with metal roofing and the area under the bin was enclosed with cement board.

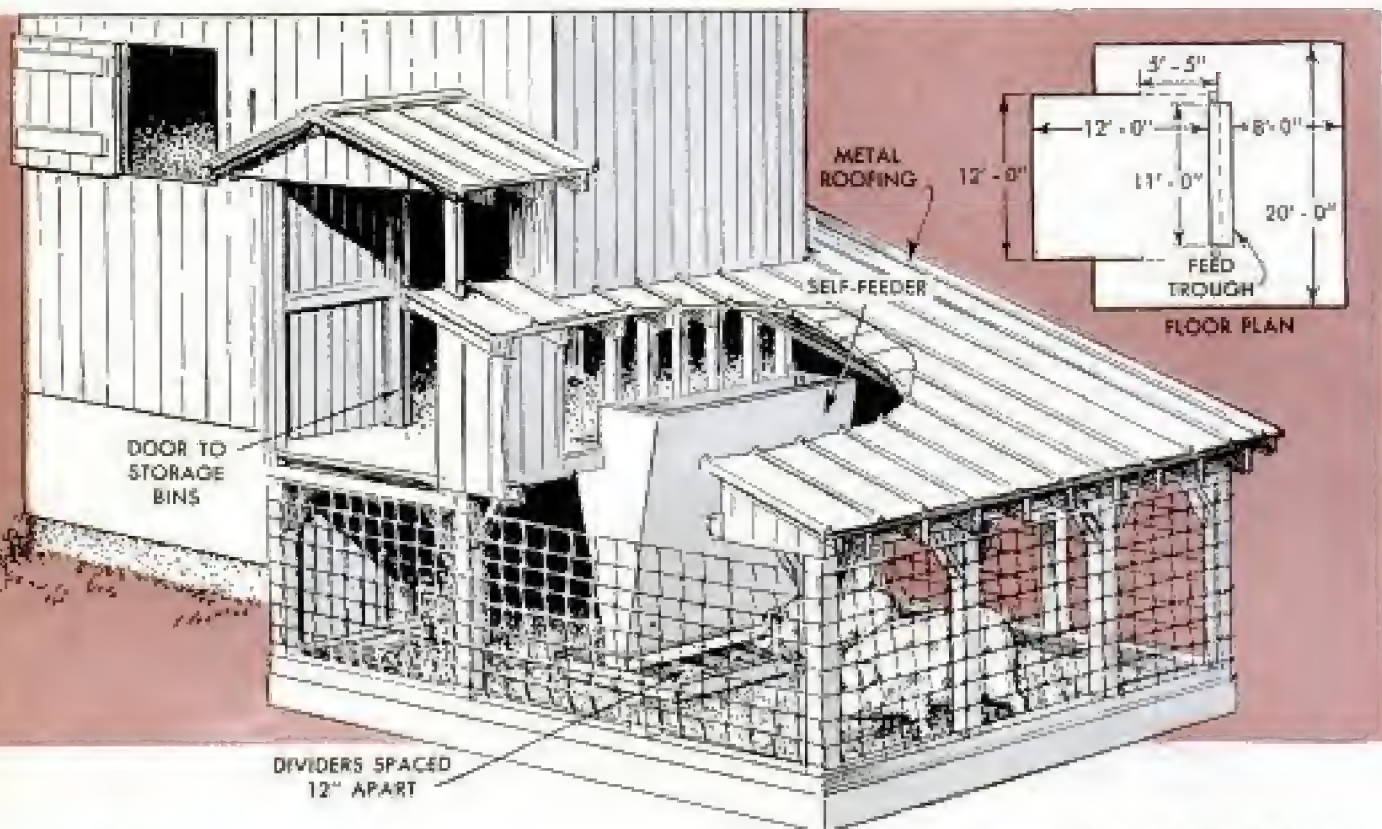

## Oil-Drum Cooler for Stationary Engine Controls Temperature

This stationary-engine cooler is used in place of a radiator and fan to maintain the water automatically while the engine is operating. The two hose connections from the engine are connected to a 55-gal. oil drum which is used as a tank. Water from the regular city supply is fed to the oil-drum tank and is controlled by a float valve. The discharge line in the bottom of the tank leads into a floor drain, and is opened or closed by an ordinary thermostat from an automobile cooling system. When the temperature of the water rises to the proper point, the thermostat opens, allowing the hot water to flow down the drain. The lowered water level in the tank opens the float valve and causes fresh cold water to flow in from the top. As soon as the water in the tank cools sufficiently, the thermostat closes the drain. And finally, the float valve cuts off the intake of cool water when the original level in the tank has been restored.—L. H. Houck, Jefferson City, Mo.



## Double Field Gates Used on Farm Accommodate Large Machinery

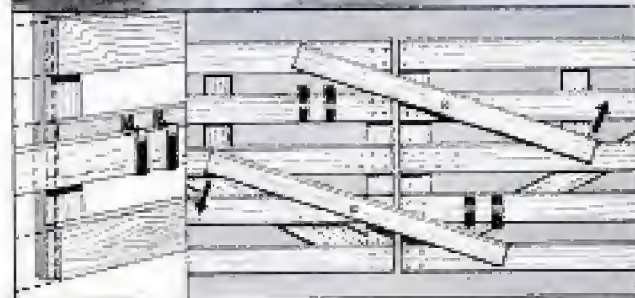

By installing double field gates in his fence, one farmer is able to pull large machinery, such as several sections of a harrow, through the gate at one time, without a need for changing the hitch or dragging the units through sideways. The gates are held closed by means of two heavy swinging bars, each of which pivots on a bolt that passes through a horizontal member of each gate, as shown in the detail. One end of each bar, extending beyond the end of the gate to which it is attached, drops into a pair of flat-steel brackets bolted to the opposite gate. For maximum strength, use bolts in place of nails when assembling the gate. When stock is in the field, the gates can be locked by chaining and padlocking the bars in place.

## Planks Chock Light Tractor to Overcome Undue Belt Slapping

When a light tractor is used on heavy belt work, the tendency of the front end to rise or vibrate and cause belt flapping can be eliminated by chocking the tractor with two planks as indicated. This method of chocking the rear wheels throws weight on the front wheels, thus steadying them against the ground.

¶Finding that the underseat heater in a station wagon didn't provide enough heat, one motorist mounted a standard heater on the fire wall, replacing the fittings in the block and water pump with pipe tees and running hoses from them to both heaters.

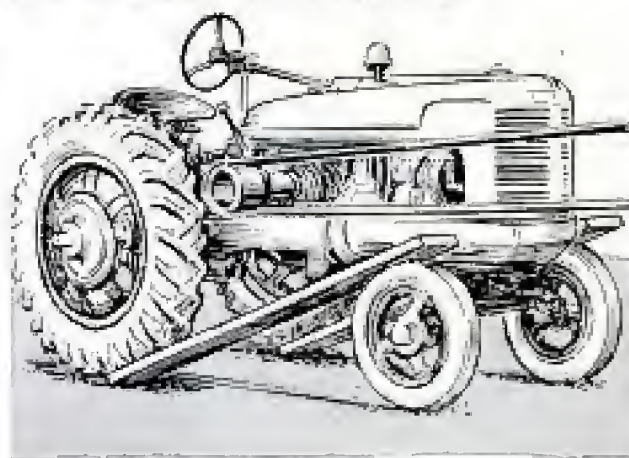

# X762



## HOW TO BUY A USED

**B**UYING A USED CAR need not be a gamble, for even the most inexperienced person can take steps to assure himself of a reasonably safe buy. Your best bet is to patronize a local dealer with a good reputation, who has been in business in your area for a number of years. Beware of so-called "sensational bargains," remembering that a legitimate dealer must make a profit to stay in business. Be cautious about warranties and guarantees. Space does not permit a lengthy discussion about these widely advertised documents, but be sure to read them carefully and analyze the wording thoroughly. In many cases they actually mean very little, and sometimes obligate the car purchaser to assume costs for repairs that should have been reflected in the purchase price. This is another excellent reason for being very careful of bargains. Though the original price is low, in the long run the car will cost more than one with a higher selling price. Do not make a hasty purchase, but shop around for a few days to get an idea of the market value of the car you want. Once you have located the make and model you desire—it is better to have spotted three or four—hire a good mechanic to look over the car. He will know how to pick a car that is in good condition, and his fee may be one

of the best investments you ever made.

However, if you must depend on yourself to make the selection, here are some simple checks that will help you to avoid buying a car that has been abused, wrecked or is otherwise not a desirable automobile.

Except for automatic transmissions on many of the later models, the checks for quality in a used car are still much the same as always. Don't let a dazzling paint-and-polish job fool you. It might, indeed, be used to cover extensive damage. Banged fenders, rusted doors and other fairly minor items, properly repaired, are not things which should stop you from buying. But look behind the sheet-metal damage and check the frame. If the chassis shows signs of having been heated and straightened, or if there are welds evident, pass up the car, even at a bargain. Although the tires and running gear do not at this time show signs of wear from misalignment, eventually there will be trouble.

While checking the running gear, take a look at the front end. The independent suspension is an expensive unit to have repaired. If the front wheels are spraddled, with the bottoms out farther than the tops, leave that car alone. And if the wheels are properly vertical or slightly out at the top, check to see that the wheels haven't been

By Jay W. Hedden



## CAR

toed-in excessively to get them to look right. With the front edges of the wheels too close together, the tires will wear rapidly. If possible, jack up one of the front wheels and rock each wheel to check for wear in the kingpin and spindle-support bushings. If it is excessive, it will cost around a hundred dollars to have the front end rebuilt. Wobble the wheel in the other direction to

Jack up the front end and rock the wheels to check for wear in the kingpin and spindle-support bushings



FEBRUARY 1954

check for worn tie-rod ends. This is not a major fault, but should be corrected immediately for good steering and to prevent undue wear on the front tires. Front-wheel tires that are cupped or worn at an angle definitely indicate something wrong with the front suspension. With the car on the ground, stand on the front bumper and rock the car with your weight. If the front end bounces easily, the shock absorbers are worn. On many cars the shock absorbers are an integral part of the front suspension and it requires overhauling most of the suspension to replace them. Good shocks will snub a car's roll after one or two bounces. The rear shocks may be tested in the same way. Assure yourself, also, that neither rear spring is weak or broken.

Check all the door latches to make sure the doors close properly and stay shut. Do the locks work? With children this is an important item. Roll the windows up and down to make sure the cranking mechanism is in working order. With the door open, compare the paint color on the edge with the color on the body. A different color here will show a repaint job. Good condition of the upholstery and floor mats generally indicate that the former owner took good care of the car, but it is possible also that seat covers have been stripped off and inexpensive floor mats installed. If the car has conventional transmission, new pedal pads might also indicate that the old pads showed excessive wear because the car had been used extensively for stop-and-go driving. This type of driving is much more destructive than high-speed, long-distance driving, when the motor is at operating temperature and the oil is properly circulating.

Turning on the key will check the gas gauge and ammeter. Start the engine and

Sheet-metal damage that has been properly repaired should not keep you from buying a used car



223



Stand on the bumper and rock car with your weight to check the shock absorbers. If the car bounces easily, the shocks are worn and will need replacing

Check the camber and toe-in of the front wheels. The wheels should be vertical or slightly out at the top. Toe-in should be very slight or zero



watch the oil pressure. It will run high at first, then as the engine warms up, will drop to normal. Covering the radiator with a blanket will quickly bring the engine up to normal operating temperature. If the oil pressure drops too far below normal, then the bearings are badly worn. To correct this will require a complete overhaul. While sitting in the driver's seat, test the brake pedal. It should be fairly firm and have about  $\frac{3}{4}$ -in. of play. If the pedal goes lower than this, but can be brought up by one pump, it is probably the adjustment. Twist the steering wheel to feel any slack in the steering-gear box or linkage. If it is excessive it should be adjusted. Get the dealer to make all the necessary adjustments and corrections before you buy any car. It is a lot easier before than after he has the money. Snap on the lights to make sure all the bulbs are good. High and low filaments in the headlights, stop and taillights in the rear. If there are directional and back-up lights, check these.

Raise the hood and inspect the engine. Here, again, cleanliness does not mean as much as it might. The engine can be steam-cleaned and painted. This does nothing for the efficiency of the inside of the engine. Pull out the dip stick and note the condition of the oil. If it is heavy, it could mean that the engine is noisy and needs heavy oil to quiet it. Or it might use too much oil of a lighter viscosity. Either way, the engine will require an expensive overhaul.

When testing an engine be sure to bring it to operating temperature. This is important because some modern engines with cam-ground pistons and extreme cold clearances will be noisy until the engine is completely warmed up. When the engine is warmed up, race it and check for noise. In a flathead (L-head) engine, any loud clunks or continuous raps mean something is badly worn. On an overhead-valve engine, some noise can be tolerated because it is difficult to keep tappets and rocker arms absolutely quiet. If the motor is quiet, but seems sluggish, have the timing checked. If the spark is greatly retarded, it can hide a connecting-rod knock or other noise.



Battery and cables should be free of corrosion  
Brake pedal should have a maximum play of  $\frac{1}{4}$ -in.



While gunning the engine, look out the back at the exhaust. A cloud of blue smoke is the giveaway of an oil-burning, badly worn engine. Black smoke shows that the engine is running on too rich a mixture of fuel. Usually a carburetor overhaul by a competent mechanic will cure it.

Examine the battery. New batteries are guaranteed from one year to about three. The age of the car subtracted from the original life expectancy of the battery will not give it too much time. It is a sensible precaution to get a new battery for any used car you buy that is much more than a year old. If, however, the battery case is clean and the battery cables and clamps are not badly corroded, there is usually a fair amount of life left in the battery. Follow down the cables to see that they are not loose or corroded on the starter and ground. The wiring to the coil and distributor, as well as to the spark plugs should not be oil-soaked or rotten. Shorts anywhere in the wiring can cause poor engine performance and low mileage, and

will cause an excessive drain on the battery.

Does the radiator show signs of leaking? Excessive loss of water or antifreeze will badly damage an engine in a matter of minutes and a new radiator is an expensive item. Soft or rotten radiator and heater hoses may burst at any time. An old hose sheds small particles of rubber and fabric that can clog a radiator.

Test-drive the car. Accelerate in all three gears, if the car has conventional transmission. In each gear listen for a growling or grinding that would indicate worn gears in the transmission or differential. If the car has an automatic transmission, run in all ranges on the indicator, and out on the highway, use the passing gear a time or two to see that it functions properly. With any automatic transmission the engine must be properly tuned to get smooth performance. So, before driving any car equipped with an automatic transmission, listen to the engine while it is idling to see if it runs evenly. Accelerate the engine suddenly. Does it hesitate a

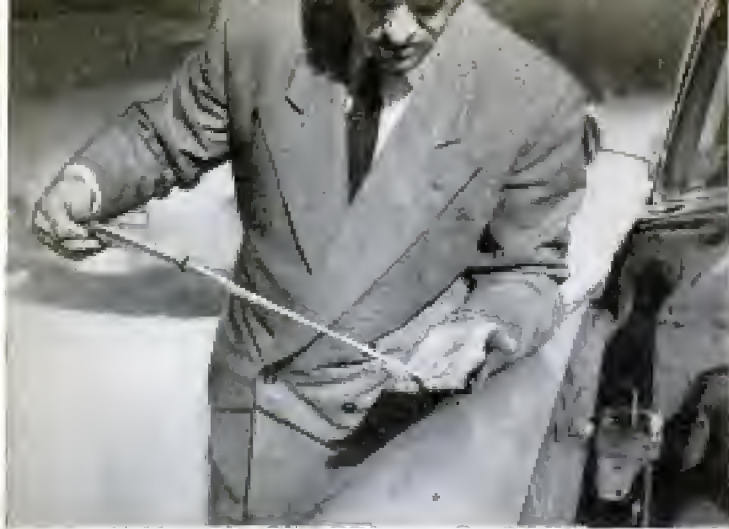

The motor oil tells a story. Heavy oil indicates that the engine is noisy and needs to be quieted or that the car uses too much of a lighter oil



A cloud of blue smoke from the exhaust shows that the car is an oil-burner. Correcting this condition requires a complete engine overhaul which is costly



Replacement or repair of a radiator is expensive. Leaks around soldered joints are easily repaired

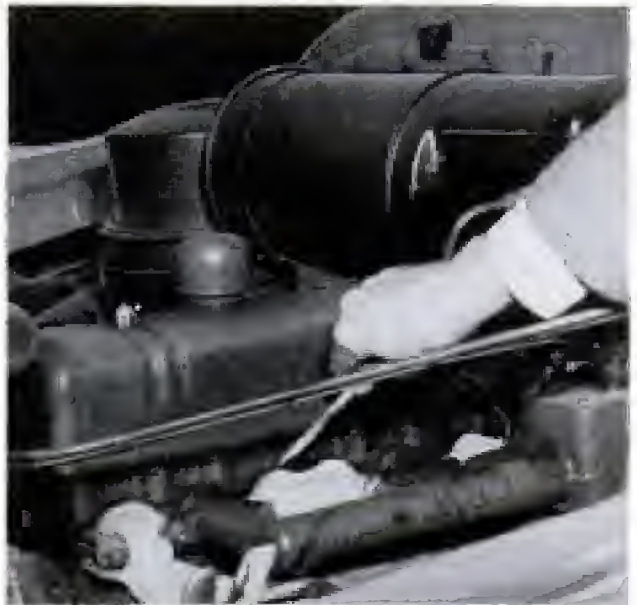

Leaking gaskets around the exhaust manifold may allow deadly carbon monoxide gas to enter car



Indicated mileage can be misleading. Long trips at high speed will cause less wear than many short trips at low speed when the engine is not completely warmed up

If the oil pan on the bottom of the automatic transmission shows oil leakage, future trouble is indicated

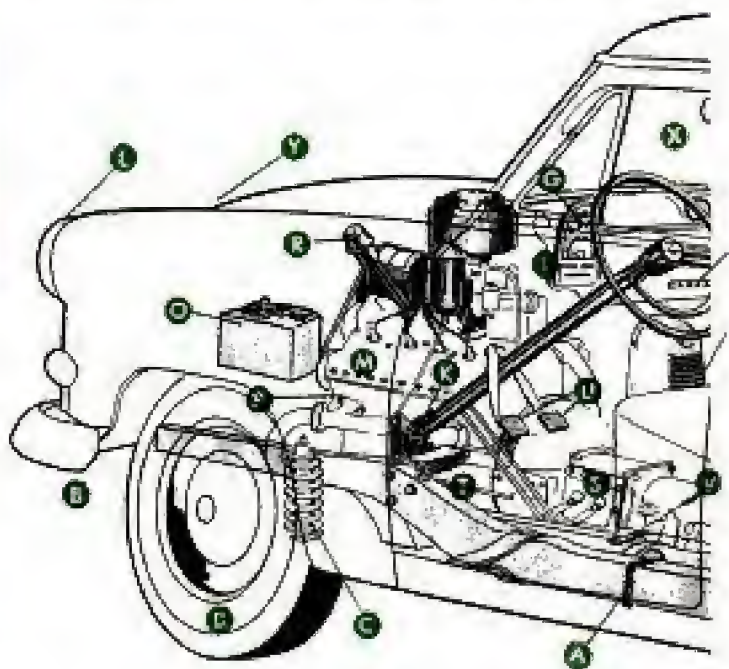



moment before "revving" up? It might be carburetor trouble, possibly the accelerator-pump system. In some cases a worn distributor or burned points will give this effect. Too wide a gap in the spark plugs will do it. Drive along at about 10 m.p.h. in high gear, then suddenly floor the gas pedal. If the motor shakes badly, vibrating the whole car, the valves will need regrinding. With any of these engine troubles, the automatic transmission cannot function properly. If you think you'd like to buy the car, have the dealer properly tune the engine, then road-test it again to make sure the rough engine did not conceal a faulty transmission. One of the biggest problems with automatic transmissions is that they will leak oil. A look under the car will show an oil pan bolted to the bottom of the transmission. If this pan shows oil leaks around the pan gasket or at either end where the drive shaft and engine connect, the oil seal should be replaced or the gasket renewed. Be sure this condition is corrected.

Although many of the items mentioned are, in themselves, minor, a number of them can add up to an expensive, unreliable means of transportation. And a number of visible defects indicating that the car has not been properly cared for by its previous owner, are an assurance that there are many other faults which you cannot see. Next to a home, the average man pays more for an automobile than for anything else he buys. Keeping this fact in mind, investigate carefully, for when spending so large a sum of money you are entitled to know that you are getting your money's worth. If the salesman does not want to let you check thoroughly, you can assume that something is wrong with the car. Buy only when you are absolutely sure. And finally, when deciding on the maximum amount you can safely spend for a used car, deduct fifty to one hundred dollars for possible repairs, even on the best car selected from the stocks of a reliable dealer.

★ ★ ★

## CHECK LIST

- A. Frame damaged or welded?
- B. Front wheels properly aligned?
- C. Shock absorbers badly worn?
- D. How good are the tires?
- E. Door latches and locks work?
- F. Window-raising mechanism work?
- G. Do all the instruments function?
- H. Heater, defroster and radio operate?
- I. Oil pressure stay constant?
- J. How good are the brakes?
- K. Slack in the steering gear?
- L. All lights operating?
- M. Engine noisy when warmed up?
- N. Oil seeps from exhaust pipe?
- O. In what condition is battery?
- P. Exhaust manifold gaskets leak?
- Q. Leaks in exhaust system?
- R. The motor oil tells a story
- S. Transmission noisy—leak oil?
- T. Clutch slip or grab?
- U. Worn brake and clutch-pedal pads?
- V. Front-seat mechanism operate?
- W. Good spare tire and wheel?
- X. Indications of leaks in windshield?
- Y. Hood misalignment indicates damage.
- Z. Is paint in good condition?

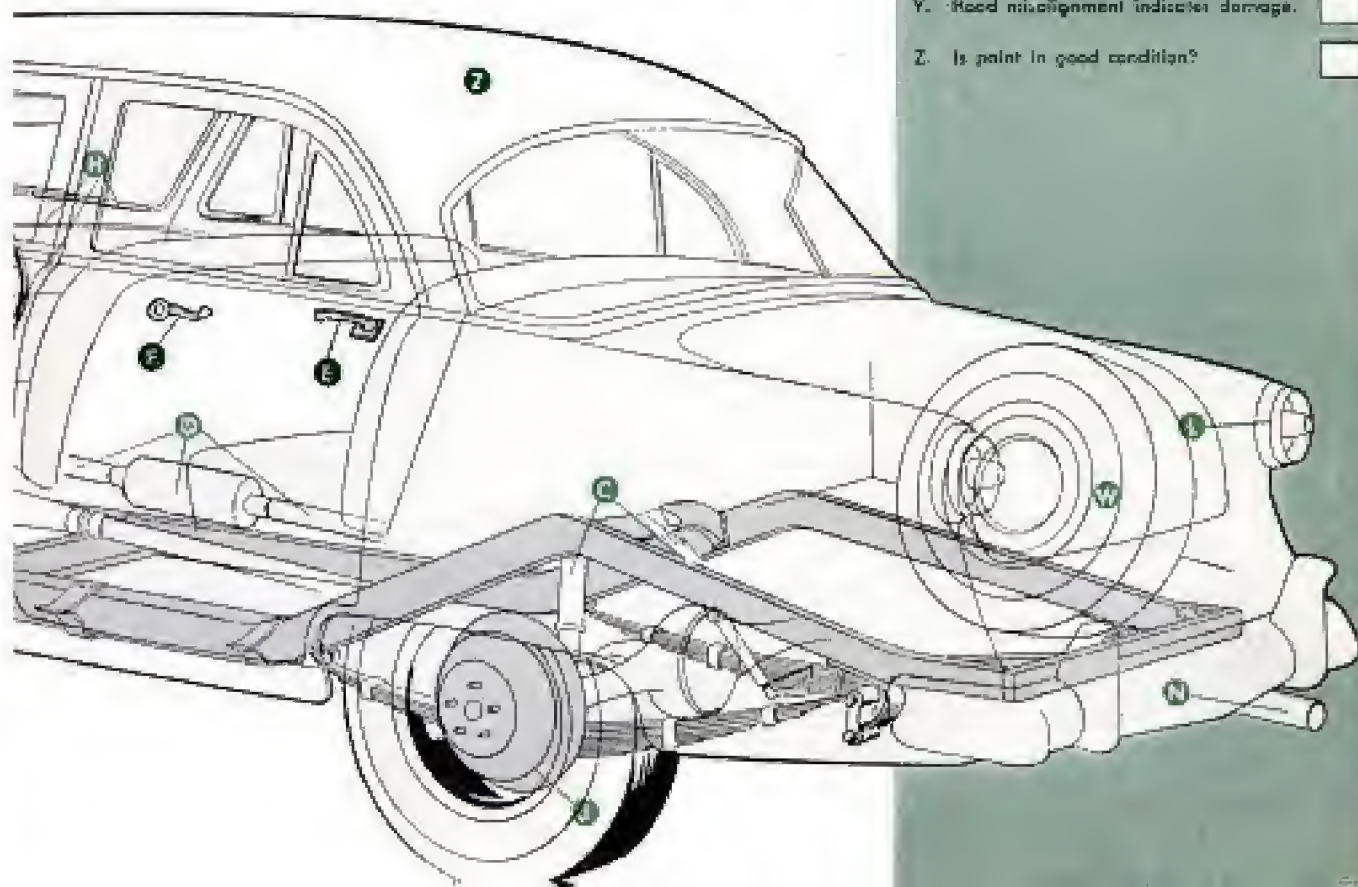



### "Rockers" Support Engine Head To Ease Bench Handling

The head from an overhead-valve engine can be handled easily on a workbench when grinding valve seats or reassembling valves by bolting it to wooden supports, or rockers, having rounded corners as shown. The ends permit turning the head over without having to lift it, and also support the head firmly in any one of four positions.

L. H. Houck, Jefferson City, Mo.

### Internally Threaded Sleeves Knurled on Special "Mandrel"

Confronted with the problem of running a deep, sharp knurl on a number of internally threaded thin-walled sleeves which were machined to close dimensions, one machinist came up with this unusual two-piece mandrel. The mandrel consists of a flanged spindle and an externally threaded bushing which is bored to a sliding fit on the spindle. The bushing is held in place with two machine screws passed through the flange with the heads in countersunk

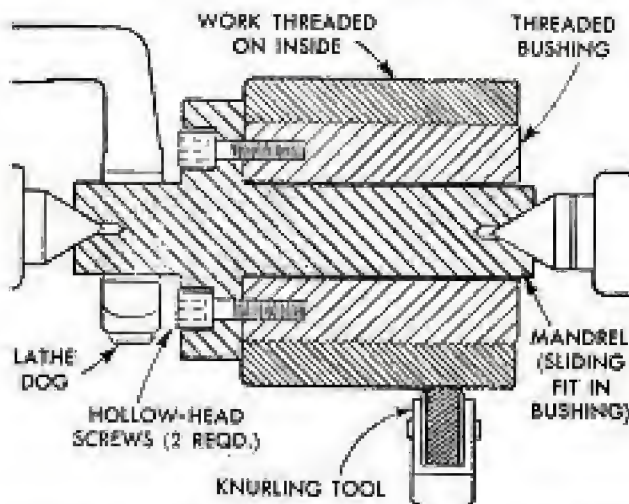

holes. In use, the work is threaded onto the bushing and run up until the end contacts the spindle flange. Then the whole assembly is mounted between lathe centers and driven by a dog. When mounted in

this way, the work cannot "freeze" on the mandrel, and the thin walls are supported adequately under the heavy thrust of the knurling tool. The same mandrel can be used on other similar types of work.

C. W. Woodson, Chicago.

### Grinding Lathe Bits for Shaper

When using lathe-tool bits in shapers, the cutting action is likely to be jumpy with the result that the bit often digs into the work and chatters along the surface. This can be eliminated to a great extent by reducing the positive rake of the cutting edge almost to neutral as indicated.

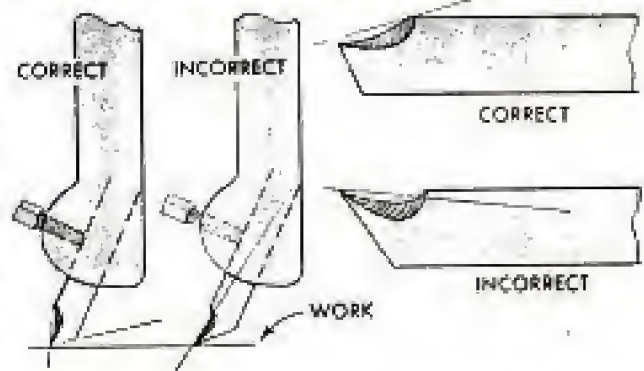

### Baffle Cast in Concrete Chute Checks Drainage-Ditch Flow

Roadside ditches along a new highway in the Southwest frequently carry off large volumes of water due to heavy rainfalls. To prevent the formation of a sand bar where the ditches drain into larger ones running parallel or at right angles to the road, concrete chutes are installed, each having a partial dam formed across the mouth as shown. Directly in front of the opening in the dam, a concrete baffle is cast on the bottom of the chute to divide the flow into two streams, thus forming an eddy which lowers the velocity of the stream. Sides of the chute are sloped so the action of the diverted water also prevents any sand and soil in the water from collecting behind the baffle and in front of the dam.—Elton Sterrett, Houston, Tex.





# Tips On Buying Used Electric Motors

By Max Alth

**A FEW SIMPLE** on-the-spot checks will tell much about the electrical and general mechanical condition of a used electric motor. Also the prospective buyer must determine whether the current characteristics, type and size of the motor make it suitable to his use. For example, if the motor is intended for use on a drill press with the shaft in the vertical position, it should be equipped with ball bearings which take thrust in two directions. Manufacturers do not recommend the use of sleeve-bearing motors in angular or vertical positions. Sleeve-bearing motors, Fig.

1, usually are provided with wool-packed bearing housings, or journals. In some cases, older type motors are fitted with chain or ring oilers which carry oil from a reservoir to the bearing when the motor is running. Some ball-bearing motors are provided with a means of greasing the bearings at intervals, others are fitted with sealed bearings which never require lubrication. In sleeve-bearing motors there is a slight end play in the shaft, but there should be no end play in a ball-bearing motor. If the shaft can be moved appreciably endwise or sidewise, the ball bearings





Only careful examination will reveal the two defects on this fan motor. Brush caps are missing and a part of bearing housing is broken away, exposing sleeve bearing to abrasive dust. Shaft may also throw oil depleting lubricant supply



Right, never accept a motor with missing or mutilated name plate. It gives the data you need to know before purchasing a used motor. Below, remove rotor so parts can be examined in detail



are either excessively worn or damaged and will require replacement. Side movement of the shaft in sleeve-bearing motors indicates a badly worn or scored bearing sleeve. Spin the motor shaft by hand several times. If it is a brush-type motor, the friction of the brushes on the commutator will offer some resistance to turning, but this will be uniform throughout a complete revolution of the armature, or rotor. However, if there is greater resistance to turning at any point, it can be suspected that the armature shaft is sprung slightly, or that the armature is striking the stator bars. Only by dismantling the motor is it possible to determine positively what is wrong. Don't purchase a used motor in this condition.

Always measure the diameter of the shaft, the diameter of the motor frame and



6

Above, run thumb along edges of keyway to detect nicks or dents in shaft. Defects must be eliminated by filing before bearing and end shield can be removed. Right, clean insulation with solvent. Below, check condition of rotor and especially starting switch, which may be defective



7



8



the distance between mounting holes in the base, as in Fig. 2. Then examine the motor frame and end shields closely for cracks or other exterior defects. The fan motor pictured in Fig. 3 is an example. Note that the brush caps are missing and that a part of the bearing housing has been broken away, exposing the bearing to abrasive dust. Also the exposed shaft may throw oil when the motor is running, thus rapidly depleting the normal supply of lubricant. Sooner or later a fairly expensive repair will be necessary to keep this unit in service.

It is never advisable to purchase a used motor with the name plate missing or mutilated so that certain entries cannot be read with certainty. The plate, Fig. 4, will give the name of the manufacturer, the type and number of the frame, horsepower, speed, all the current characteristics and, on certain types of motors, will include wiring diagrams showing how to connect

to the line for operation on 115 or 230-volt current. Check all entries on the name plate so that you will know what type and size of motor you are buying and on what current it is designed to operate. If the name plate states that the motor will operate on either a.c. or d.c., the motor is the universal or series-wound type used in portable drills, saws and similar power tools. As a rule such motors are not suitable for stationary machines which must be driven at constant speed. The speed of the universal motor tends to vary with the load, the no-load speed being much higher than the load speed.

Where it is possible to remove the end shields and examine the rotor and stator, Fig. 5, be sure to first run the thumb along the edges of the keyway as in Fig. 6. A nick or dent here will have to be removed by filing before you can slide the bearing off over the shaft. If the motor is of the brush

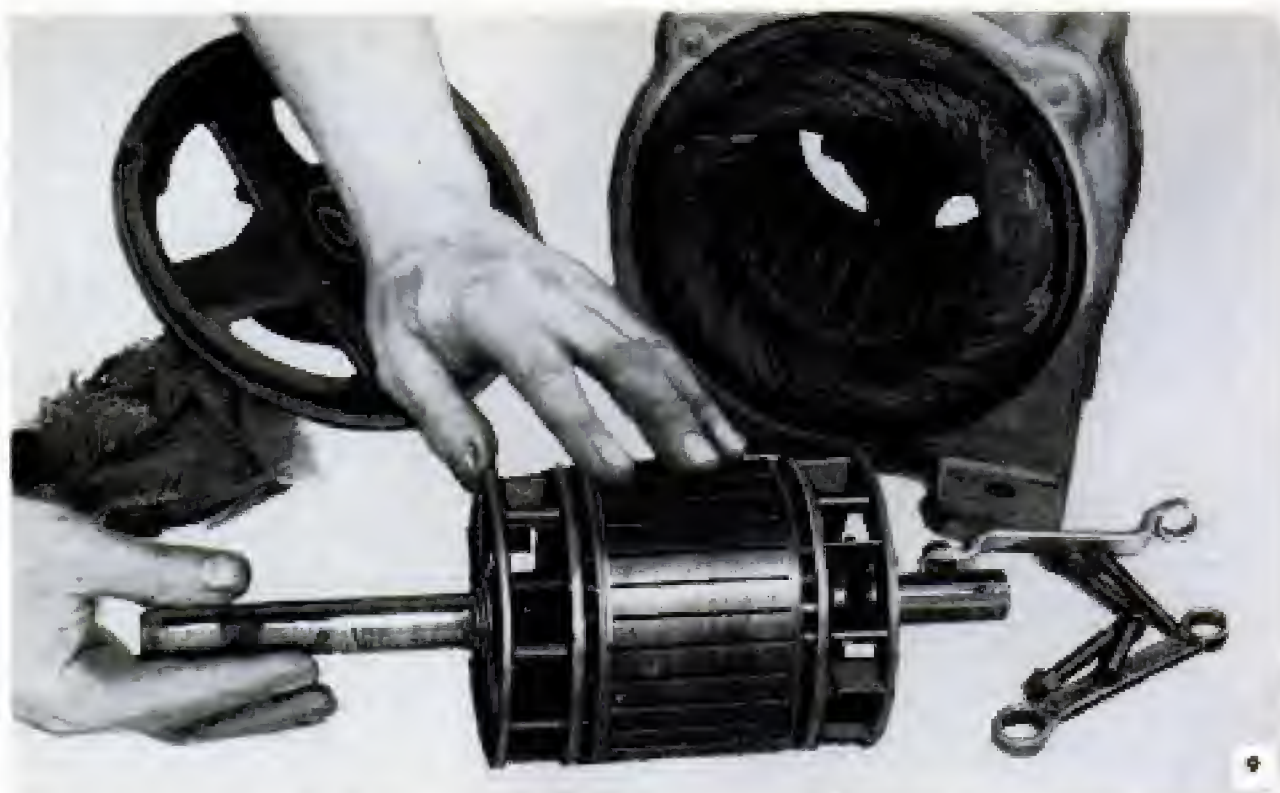

When cleaning an old motor it pays to dismantle it entirely and do a thorough job. Use a harmless solvent such as carbon tetrachloride. Don't use flammable solvents such as lacquer thinner or naphtha

type, then remove the brushes before withdrawing the rotor. When removing the brushes be sure to keep them in order so that they may be replaced in the same positions as they were originally. While the motor is open examine the insulation closely. Remove the dust and accumulated grime with a cloth dipped in carbon tetrachloride, Figs. 7 and 9, so that you can see the insulation clearly. On some older-type motors the exposed loops of the coils are coated with a special varnish. Examine this coating closely for breaks or evidence of charring. If it appears to be intact and the insulation on the leads is in good con-

dition, then it probably is safe to assume that the motor still is in serviceable condition. Examine the commutator or the starting switch, Fig. 8, depending on what type of starting mechanism may be employed. If the brush track on the commutator is rough, pitted or grooved, it may be necessary to true up the surface in a lathe and also undercut the mica separators between the copper bars of the commutator to put the motor in condition.

Single-phase motors of the capacitor type in fractional-horsepower sizes are almost universally used on home-shop machines. Capacitor motors are fitted with special starting windings or starting coils which have the effect of reducing current requirements during the starting period and at the same time enable the motor to start medium loads. On equipment having a heavy starting load, such as an air compressor, repulsion-induction motors generally are used. The repulsion-induction motor starts as a series-wound motor and runs as an induction motor, the change being effected during the starting period by a centrifugal device which short-circuits the commutator before the armature, or rotor, reaches normal operating speed. These motors develop more than their rated hp. during the starting period and will start exceptionally heavy loads. Both types of motors are designed to operate at a constant speed. Fig. 10 pictures an older motor with brushes mounted to contact a disk-type commutator. ★ ★ ★



# Draftsman's Perspective Liner From Yardsticks

A draftsman's perspective liner can be made easily from three yardsticks. The sticks for the two shorter legs are cut to 27 in., and the three pieces are pivoted together near the ends with a small bolt and wing nut. Thin washers are used to prevent the bolt head and wing nut from sinking into the wood, and the head of the bolt is filed as flat as possible so the liner will lie close to the work. When the liner is adjusted to show the vanishing point to be somewhere beyond the edge of the board, two push pins are pressed into the board to support the two short legs. — Walter L. White, Chicago.

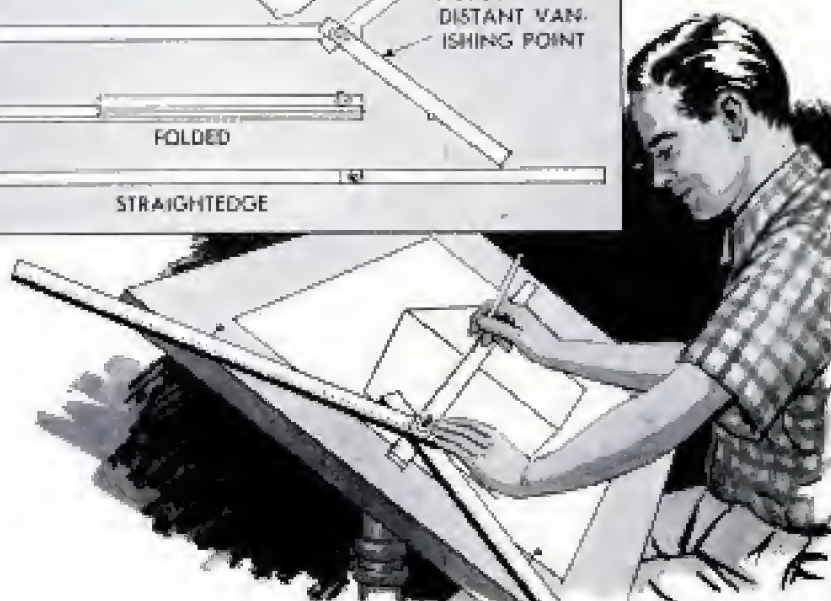
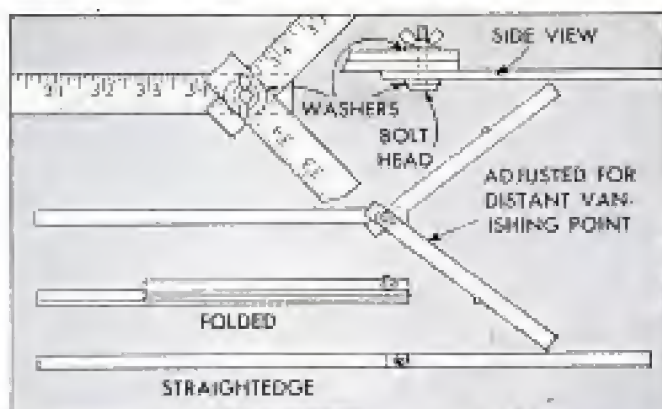

## Modified Portable Hand Router Cuts Accurate Circles



Round table tops, pedestals and other circular shapes can be accurately cut with a portable hand router, if it is modified by means of a simple attachment. First, remove the two bars on which the fence slides. In their place, fasten an L-shaped piece made of lengths of 1-in. stock, as shown in the illustration. In the middle of the foot of the L, secure a length of  $\frac{1}{2}$ -in. hardwood, in which a series of  $\frac{3}{16}$ -in. holes have been drilled. In use, a  $\frac{3}{16}$ -in. hole is drilled in the center of the work and a  $\frac{3}{16}$ -in. dowel is slipped through the hole in the arm of the jig, and into the hole in the work.—M. B. Birge, Hinsdale, Ill.

## Inexpensive Way to Coat Nails for Use on Special Jobs

If you have a job where coated nails, because of their greater holding power and rust resistance, are required, ordinary self-polishing floor wax can be used to make your own coated nails. Place the nails in a clean tin can, cover them with the floor wax, and then pour the wax back into its own container. Allow the nails to dry before removing them from the can. Small amounts can be economically treated.

☐ In laying out accurate holes to be drilled in wood or metal, make a ring of center-punch marks on the circumference of the hole. This will aid in relocating the center if the drill slips to one side when starting.



# Know Your Metal Shaper

By Sam Brown

**M**ILLING MACHINES and metal shapers do similar work in the machine shop, but in entirely different ways mechanically. A milling machine removes metal from the work by means of a rotating, multiple-toothed cutter mounted on a spindle, the speed of which is variable through a cone pulley and back gears. On the shaper, the cutting tool is carried on a ram which is driven back and forth, moving the single-point cutting tool across the surface of the work in a straight stroke. The single-point tool is one of the advantages of the shaper as it is inexpensive and permits fast setups on nearly all ordinary jobs. On a basic shaper operation, such as that in Fig. 5, the single-point tool removes metal faster than a milling cutter.

**Bench shaper:** A 7-in. shaper—one with a 7-in. maximum ram stroke—is a common choice for home model shops and small machine shops. Its main operating parts are shown in Fig. 1. The length of the ram stroke is easily adjusted by turning a crank on the side of the machine until the pointer is opposite the required stroke length indicated on a scale. The stroke of

the ram also can be positioned front or rear with relation to the table, Fig. 2. This is done by means of an adjusting stud on the top of the ram. Where the work will permit, always set the rear limit of the stroke as near the column as possible to avoid overhang of the ram. Most small shapers have four speeds ranging from 50 to 200 strokes per minute (average values). The machine table is fitted with power feed which can be set to feed from .005 to .030 per stroke. Fig. 3, the values varying with different makes of machines. The feed is reversible, right or left, and is timed to occur on the noncutting backstroke. The tool post is mounted on a swiveling clapper box, Fig. 4, which permits it to swing free on the backstroke. This prevents scoring the work, which would be likely if the tool were mounted rigidly.

**Planing a block:** Surfacing all six sides of a steel block is a typical shaper operation and as time is saved by working the cutting stroke the long way of the block, this job is carried out by turning the vise sidewise, Fig. 7. After the No. 1 side is planed, Fig. 6, it is placed against the fixed

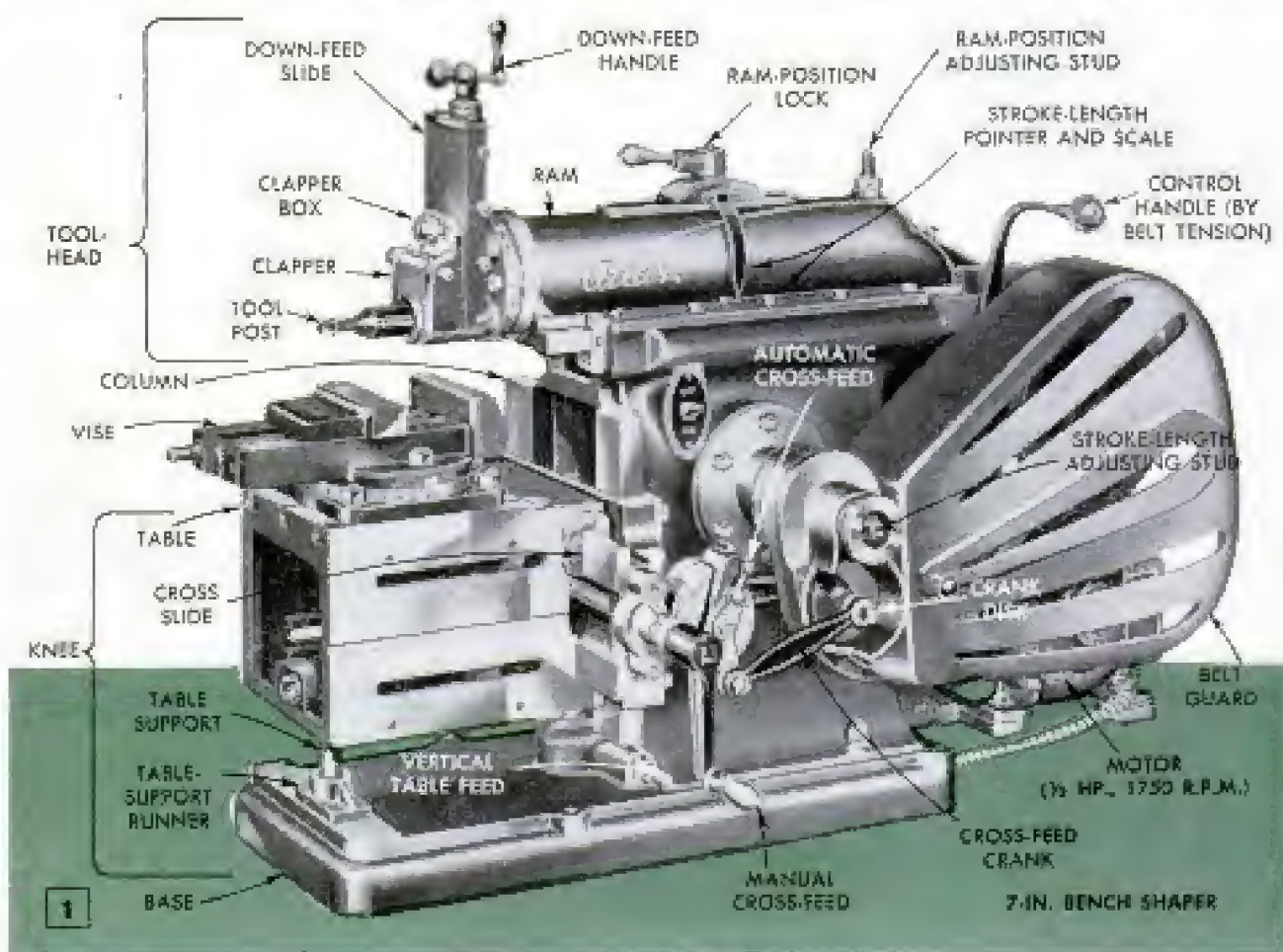



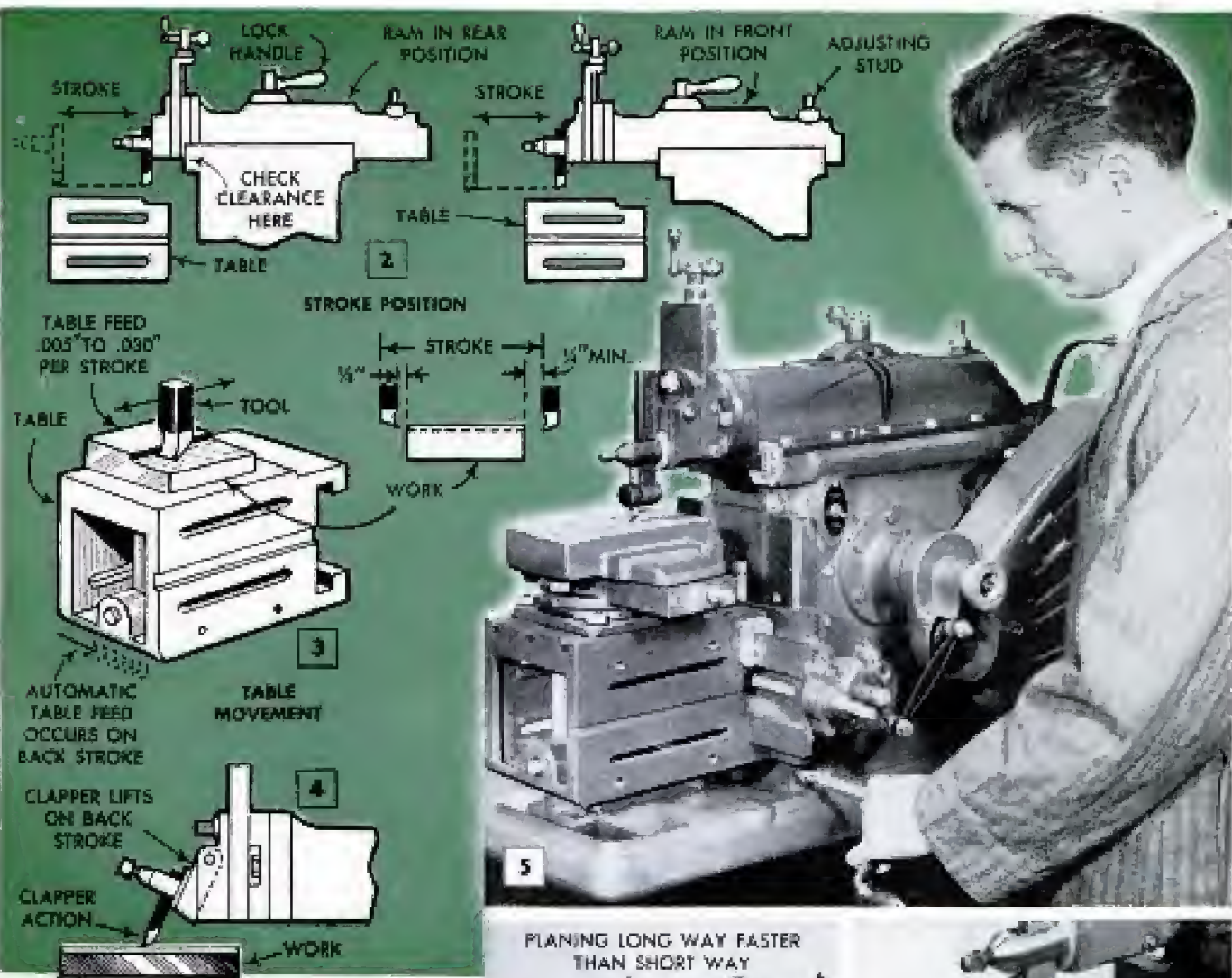

jaw of the vise as in Fig. 8. Side No. 3 is worked the same as side No. 2. It's important in such operations to keep the work seated true in the vise. This usually is done by tapping the work with a soft hammer as the vise is tightened, Fig. 9. Never strike the work a hard blow while it is on the machine table; a light tap does it. Where direct miking is required, Fig. 10, the work should be arranged to overhang the vise. The block shown is short enough so that ends numbered 5 and 6 can be worked with the piece held upright in the vise, Fig. 11. All surfaces are planed with the automatic feed, .010 to .015 being a good working value. Most operators prefer to cut from right to left, Figs. 5 and 7, as this allows the best view of the tool. Successive cuts are set by cranking the table back by hand.



6 ORDER OF CUTTING



7 PLANING FACE No. 1

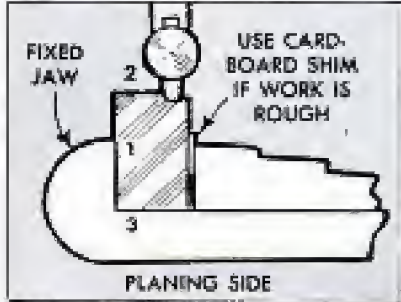

8 PLANING SIDE No. 2

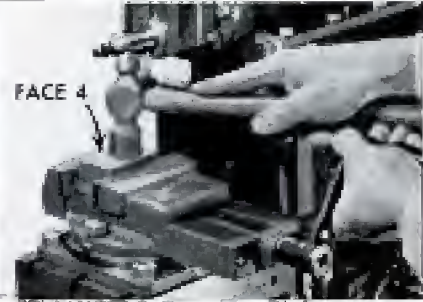

9 SETTING UP FACE No. 4



10 POSITION FOR MIKING



11 MAKING THE END CUT

12 <b>Recommended SHAPER SPEEDS</b>	
MATERIAL	F.P.M.
ALUMINUM	100 TO MAX.
SET PLASTICS	100 TO MAX.
THERMO PLASTICS	60 TO 120
YELLOW BRASS	80-100
CAST IRON	50-80
SOFT STEEL	40-70
MACHINE and LOW-CARBON STEEL	30-70
HARD STEEL	20-50
40 to 60 F.P.M. is practical working range for all machining materials	

Length of Stroke	13 <b>FEET PER MINUTE SPEEDS</b>							
	NUMBER OF STROKES PER MINUTE							
	45		78		122		186	
	Forward Travel	Cutting Speed	Forward Travel	Cutting Speed	Forward Travel	Cutting Speed	Forward Travel	Cutting Speed
1"	4	7	7	13	10	19	16	30
2"	8	14	13	24	20	38	31	59
3"	11	21	20	36	30	57	47	86
4"	15	27	26	48	41	74	62	113
5"	19	34	33	58	51	91	78	139
6"	22	40	39	69	61	107	93	164
7"	26	45	46	77	71	121	108	184

Light-face figures are net feet cut per minute, calculated by multiplying length of stroke by number of strokes per minute.

Bold-face figures are cutting speeds in feet-per-minute — the same valuation which is used in pacing other machine tools.

14 <b>INCHES PER MINUTE TABLE FEED</b>				
FEED PER STROKE	STROKES PER MINUTE			
	45	78	122	186
.005"	¼"	⅜"	½"	"
.010"	⅜"	½"	1½"	1¾"
.015"	"	1"	1¾"	2¾"
.020"	¾"	1½"	2¼"	3¾"
.025"	1¼"	2"	3"	4¾"

Figures are approximate. Use this table to determine time required to traverse any specific width.

In some instances it is practical to make a cut with the table traveling in two directions. Work reversal is accomplished simply by shifting the reversing lever on the machine.

**Down-feeding:** Not all types of work can be mounted upright for surfacing cuts. In this case the tool is down-fed by hand, using the toolslide as in Fig. 15. In the work example shown in the detail, Fig. 15, sides numbered 1 to 4 are worked as in Figs. 6 to 11, but the ends 5 and 6 are worked by down-feeding. The cutting edge of the tool should incline away from the work as in the center detail, Fig. 15. Manual down-feeding on the shaper is perhaps the only operation where the hand remains on a moving part of the machine. It is quite safe if you use a slow ram speed and keep your eye on the job. A few minutes' practice will be required to get the feel of the moving ram. After that timing of the manual feed is easy, although it is advisable to use the slowest ram speed in the beginning, as the feed cannot be maintained at a precisely uniform rate.

**Clapper position:** When down feed is

used it is necessary to swivel the clapper box, Figs. 16 and 17. The correct position of the box is shown in the center detail, Fig. 16. In this position the tool will swing outward and away from the work on the backstroke. The tool can be worked as in the left-hand detail but there is some danger of scoring the work. Note, Figs. 16 and 17, that the tool swings out in the same direction as the top of the clapper box is inclined. Thus, if you are cutting the right end of work the clapper box must be swiveled to the right, Fig. 15, and if the cut is made to the left, the box is swiveled as in Fig. 16. Swivel the clapper box for all angular cuts, Figs. 27 and 28. Clapper-box swivel is sometimes used on flat surfacing jobs to clear the shoulder of the cut, Fig. 25.

**Shaper tools:** Cutting tools are similar to lathe tools and have a similar cutting action. Usually the tool bit is mounted in a holder, but larger tools are mounted directly in the tool post. The holder ordinarily is mounted with the tool at the front, but a reversed position, Fig. 18, is often useful when making finishing cuts. Tool shapes are variable, you can use almost any shape having clearance behind the cutting edge. Many shaper operators like the all-purpose tool detailed in Fig. 19. A side-rake tool, it cuts only to the left, the table moving to the right. It can be ground with both side rake and back rake. The round-nosed tool, Fig. 20 cuts right or left, while the finishing tool, Fig. 21, normally a square-nosed tool, is detailed with the edge ground for cutting to the left. Note that this is opposite to the angled edge of the all-purpose tool. The finishing tool makes a wide cut and will give a smooth finish with feeds up to maximum if you use a shallow cut not over .010.

**Internal cuts:** Various solid tools and

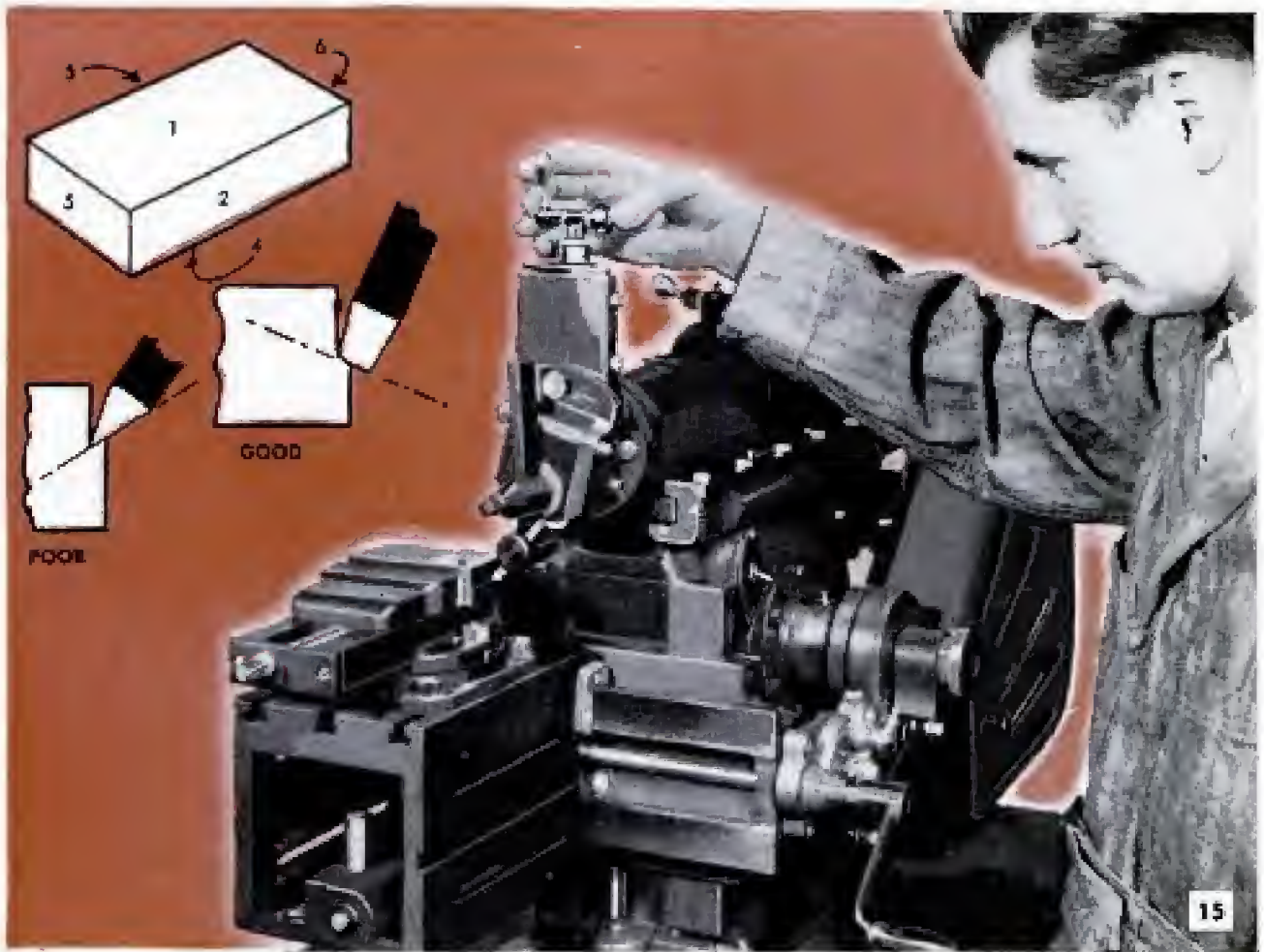

bars with inserted cutters are used for internal work, the general type of these accessories being the same as that used for boring in a lathe, Fig. 24. A common internal job is cutting a key seat, or keyway, Fig. 29. When the work opening is small the clapper must

be locked by fitting a metal bar behind the tool post as in Fig. 23. Down feed must be timed so that the tool clears the work, Figs. 22 and 24.

**Speeds:** The tables, Figs. 12, 13 and 14 will be useful in determining speeds for the common metals, feet-per-minute speeds and also determining the time required to traverse work of a given width. The typical jobs pictured and detailed in Figs. 25 to 29 inclusive, are good examples of the range of ordinary shaper work, but, of course, do not include special setups for machine and model parts. The shaper does excellent work on plastics and can even be used on hardwoods where cuts can be made with the grain.

**Operating Pointers:** In order to get the most out of the bench-type shaper in performance

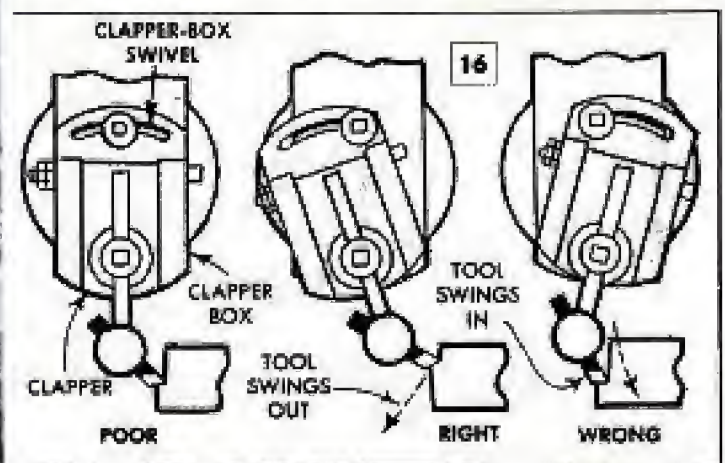
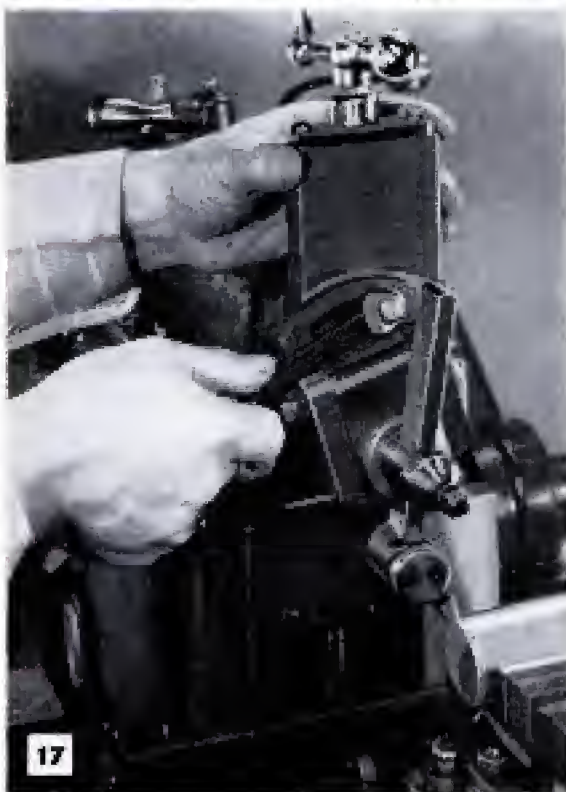



and accuracy, good practice requires that it be mounted on a rigid bench, or stand, with the table at a convenient height for mounting the work and making adjustments. The machine will not operate satisfactorily on an unstable bench or stand, especially at the higher ram speeds. When setting up the work and checking the operation of the ram, be sure that it is adjusted so that the cutting tool clears the work on the back stroke and that there is ample time at the end of the stroke for the clapper to drop before the tool again engages the work on the cutting stroke. Otherwise the clapper may not fully drop before the tool engages the work. The tool should just clear the work at the end of the cutting stroke. In most cases a longer stroke is unnecessary, except possibly in certain finishing operations. When grinding a round-nosed tool be sure that the cutting edge is ground and honed to a true radius. It is especially important when grinding to avoid the formation of tiny Vees in the cutting edge as a Vee may produce scores in the surface that are difficult to remove without remachining the entire surface. When bringing nonferrous metals to close dimensions, take light cuts. ★ ★ ★

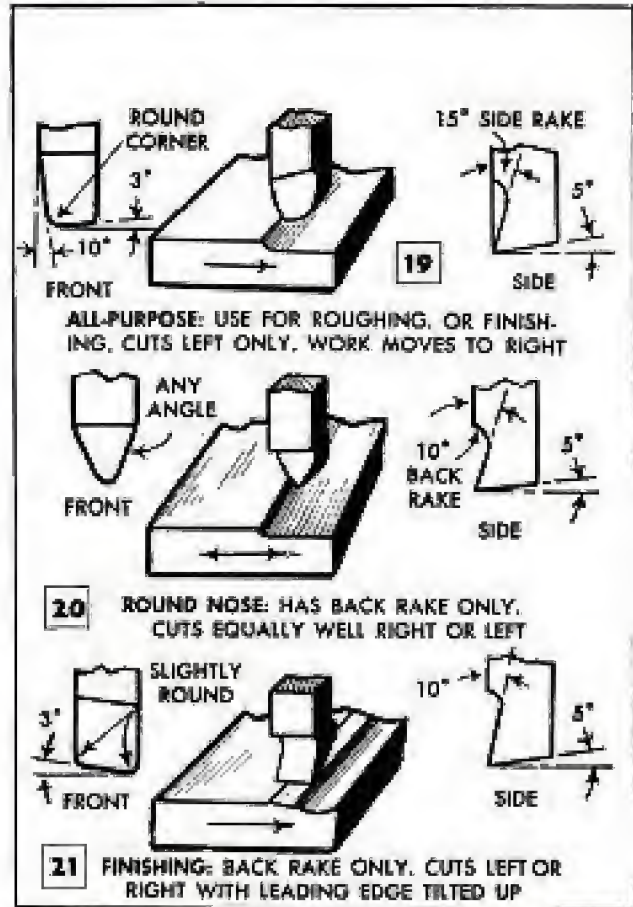
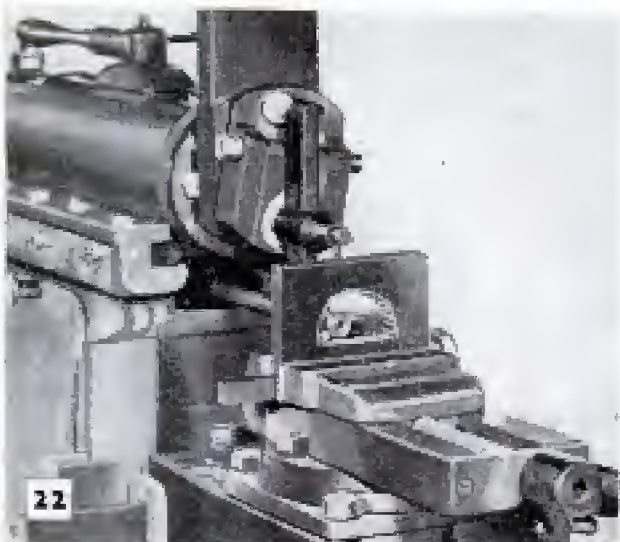

Cutting tools used in shaper are similar to lathe cutting tools. Reversed position of holder, above left, is often useful when making finishing cuts

Internal cuts require extension bar and holder similar to that used in lathe. Typical setups are shown in lower photos. Note metal bar locking the clapper

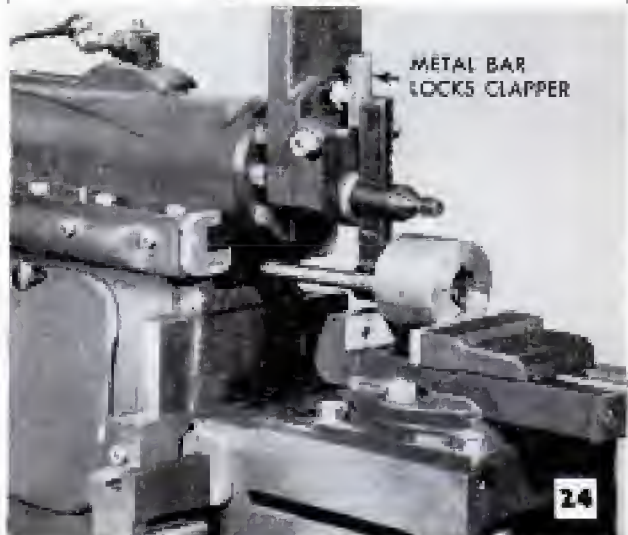
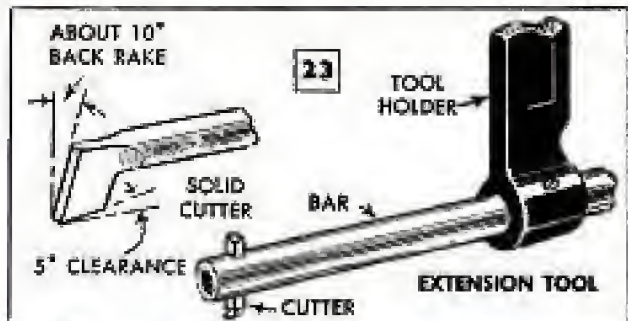

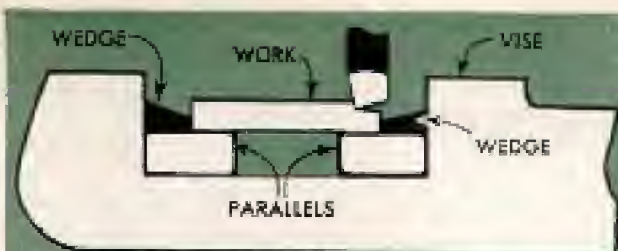

This work is mounted in vise with wedge blocks having one edge thinner than work for clearance. Direct mounting on machine table is practical. Ply-wood base is used under work to permit edge cuts

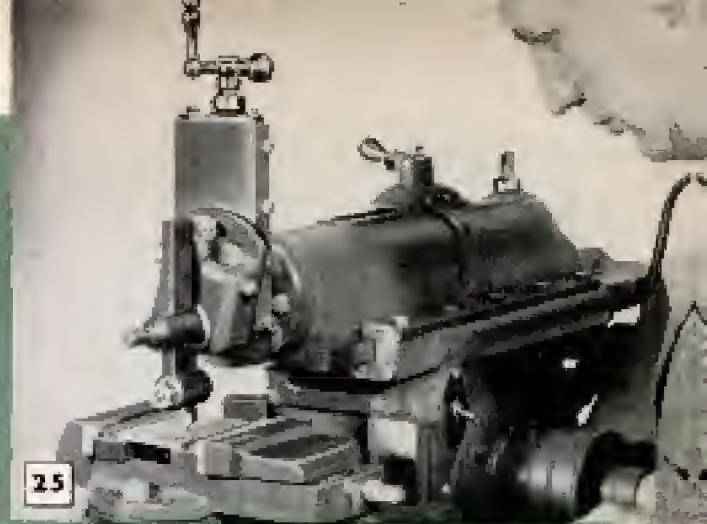

25

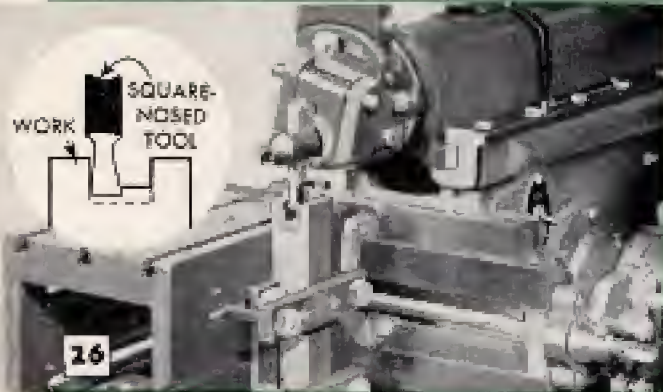

26

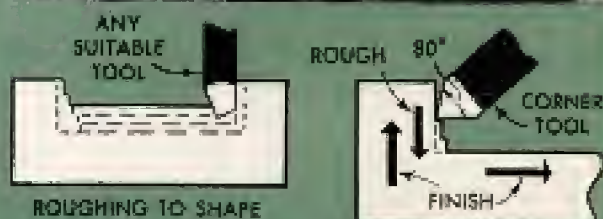

Right-angle corner is worked with square-nosed or corner tool. With edge slightly inclined tool will cut a very smooth surface with up-feed. Use down feed for the roughing cuts

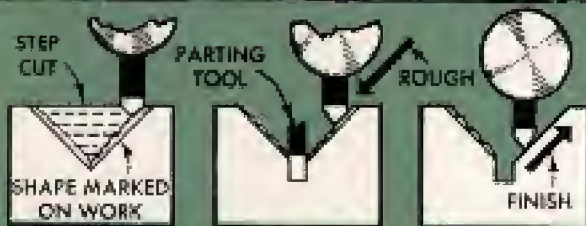

A V-block is cut with the swiveling toolhead set at 45 deg. Work can be reversed in vise to finish second side rather than swinging tool-head. Automatic feed is used for roughing cuts



27



28



Dovetailing usually requires 60-deg. angle of swiveling head and is cut with tool ground to 50 deg. Roughing is done with forward edge of tool and finishing cuts are made with the side

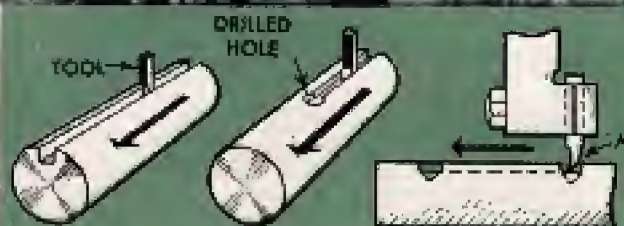

Keyways are cut with square-nosed tools. Blind ends require drilled holes for clearance. Heel of tool, A, may require grinding to clear. Reversed toolholder helps to prevent chattering

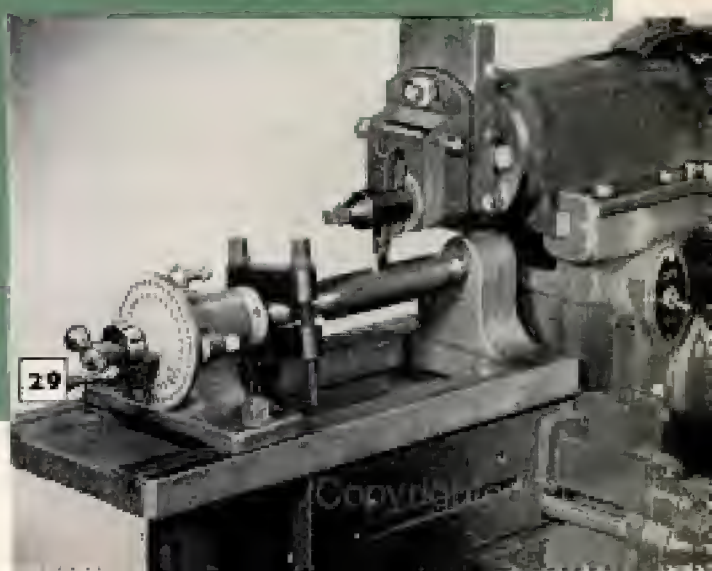

29

## Novel Blueprint Lamp Shade For Den or Workshop



An old blueprint, perhaps of your own house, makes an attractive lamp-shade covering for a man's den or workshop. Use the type of shade that has the top and bottom loops fastened together with corner wires. Strip off the old shade, use it for a pattern and cut the new cover from the blueprint. It can be fastened to the frame with glue or cellulose tape.

L. C. Auer, La Porte, Tex.

## Glass Cover Protects Price List

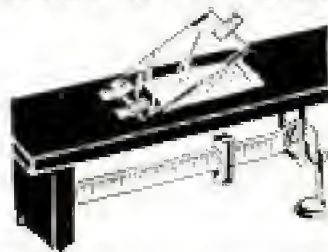

When price lists or buyers' quotations must be kept outdoors or on an open warehouse scale, they can be protected from weather and dirt

by a glass cover. Ordinary adhesive tape is used to hinge the glass and form a tab, so the glass can be lifted to change lists.

## Pipe-Joint Sealing Compounds

A knowledge of the various kinds of commonly used pipe-joint compounds will aid in using the correct type for a specific job. White lead, carbonate of lead ground in boiled linseed oil, is durable, but should be given sufficient time to harden properly. Red lead, oxide of lead ground in boiled linseed oil, hardens quickly and is preferred where pressure is to be applied soon after the pipe fitting is finished. Red lead is not as durable as white lead. A graphite compound is excellent on brass piping. Its low coefficient of friction allows the joints to be made up more tightly and aids the natural seating properties of brass. Lith-

arge is lead monoxide, made by heating lead in a current of air and is a quick-setting compound, useful for higher pressure installations. It is used in several mixtures for application on poorly fitted joints where extreme service conditions are expected.

W. F. Schaphorst, Newark, N. J.

## Pressman's Nonslip Finger Cot Is Worn Without Discomfort

Pressmen operating platen-type presses often improvise a friction finger cot from a narrow strip of sandpaper and a rubber band to facilitate lifting printed sheets from the press. Although efficient for the purpose,

such a cot often causes marked discomfort after a short period of use due to the necessary tension of the rubber band. This problem is easily solved by utilizing a finger band cut from a plastic thimble of a size to fit the middle finger loosely. In use the strip of sandpaper is looped over the end of finger and the plastic ring pressed lightly over it. The sandpaper does not smear type impressions when lifting sheets from the press, and the cot can be worn for long periods without discomfort.



## Clock Spring Renews Oil Can

When the bottom of an oil can has lost its tension and will no longer snap back when depressed, it can be renewed by using a length of heavy clock spring. A small bracket is shaped from sheet metal and soldered to the bottom of the can. A length of clock spring, measured to fit across the bottom of the can, is cut by bending sharply and then slipped under the bracket.



## Work Mounted on Steel Balls Prevents Wear of Centers

Where necessary to taper-turn stock with an extreme setover of the tailstock on a metal-turning lathe, one machinist mounts the work on steel balls as shown, to prevent wearing and scoring of the centers. This is done by grinding off the points of two live centers (not heat-treated), and then center-drilling the ends with the same center drill as the one to be used for the work.—Milton Wittner, Brooklyn, N. Y.

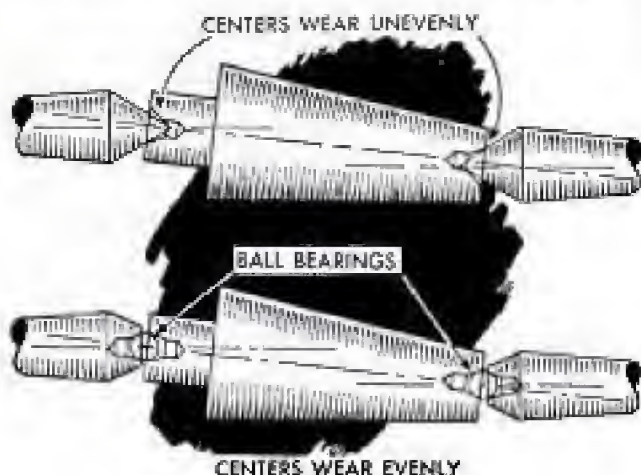

## Coupling and Extension Help Thread Short Pipe Nipples

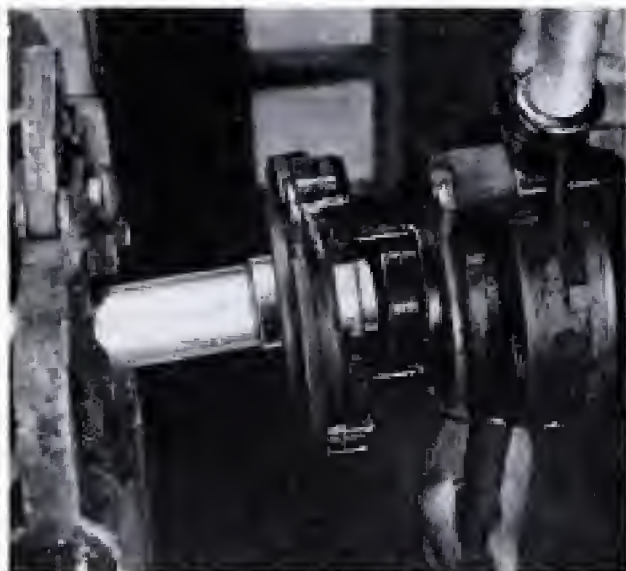

To thread a pipe nipple which you know will be too short to be held in a vise for threading, use the method shown. Thread one end of a piece of pipe and cut the nipple to length. Screw this into a coupling, which is in turn screwed onto a piece of pipe long enough to be held in the vise. From this point thread the nipple in the usual way. In the illustration shown, the collar of the ratchet is set over the coupling to get the threading close enough to cut a full thread.—Michael Ligocki, Gary, Ind.



## Gate Speeds Up Stock Handling

In order to speed up handling and shipping of livestock, one farmer installed a two-way gate leading to his loading chute that could be swung to close either of two adjacent pens. The loading chute is permanently located in the feed lot and centered on a line with the gate. I-beams salvaged from an old platform scale were set vertically in concrete and the side boards of the chute were bolted to the flanges. The chute floor can be adjusted to equal the height of the particular truck bed and is swung up when not in use.

Arthur Trauffer, Mt. Pleasant, Iowa.

## Masking Tape Covering Can Rim Prevents Filling With Paint

If you dislike having paint collect on the can rim, and perhaps run down the sides, cover the rim with a strip of tape as indicated. Masking tape is best for this purpose, but any tape that will adhere to the can may be used. If tape is not available, try using a strip of aluminum foil, crimping it down over the rim on both sides of the can. When replacing lid, remove tape or foil.



# SHOPPING FOR TOOLS

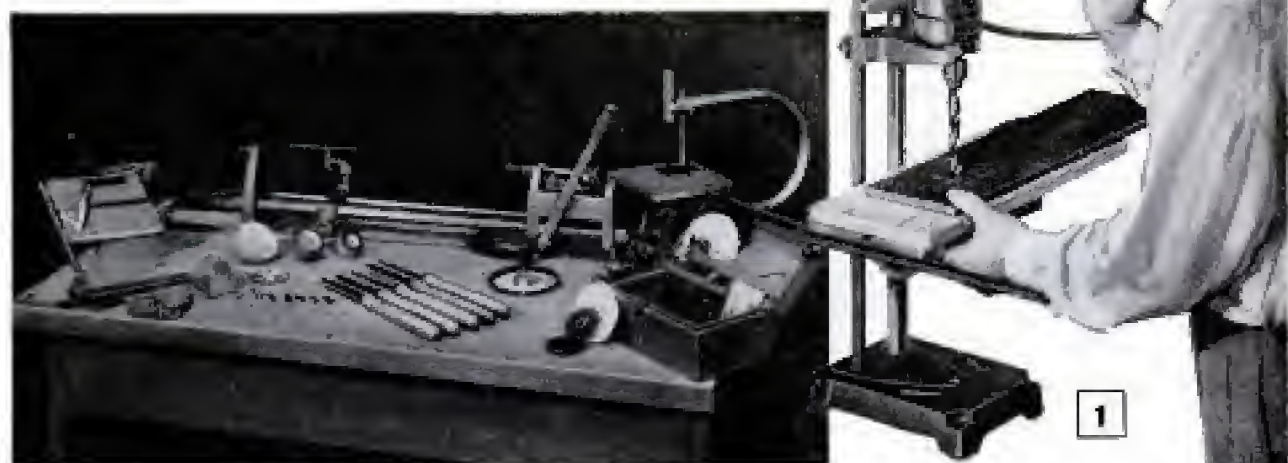

**1. TABLE-TOP WORKSHOP** is powered by a portable electric drill of  $\frac{1}{4}$ -in. capacity. Shop includes lathe, circular saw, disk and drum sander, vertical drill press, horizontal drill and router-shaper. A jigsaw is available as an accessory. Compact design enables owner to work in limited space—the whole unit sets up ready for work on a kitchen table or small workbench. A simple change of parts converts the unit to a lathe, circular saw, or vertical drill press. When set up as a lathe it has a capacity of 24 in. between centers

**2. ELECTRIC CUTTER** for plastic tile makes clean, sharp cuts, either curved or straight. Cutting point, or "chisel," is hook shaped, is electrically heated and easily manipulated in much the same manner as a pencil. Unit also is supplied with special welding points for welding the tile joints after placement

**3. SCREWDRIVER** has four swiveling blades pivoted in a sliding shank. Blades nest into a slot in the shank in such a way that when the latter is pressed back into the handle none of the blades project and tool is reduced in length so that it is easily carried in the pocket. Driving bits fit four sizes of screw slots

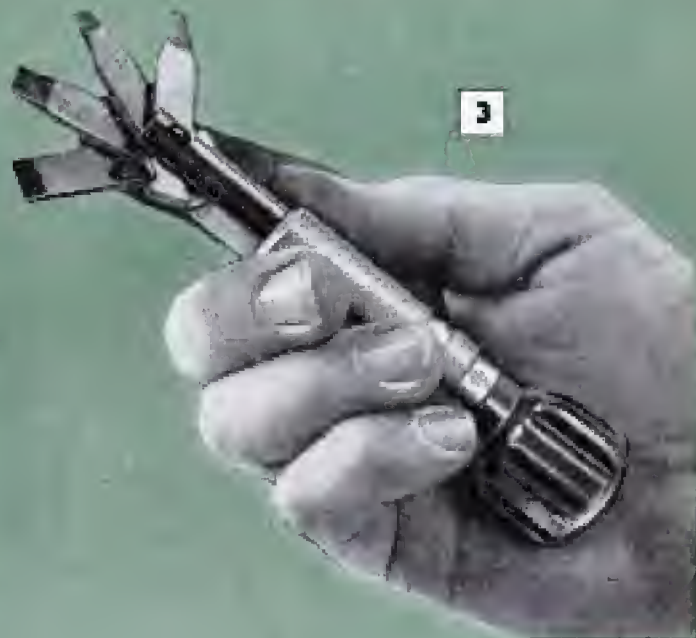



**4. PORTABLE ELECTRIC DRILL** powers this combination unit which converts to lathe, grinder, sander-polisher, vertical drill press and circular saw. Performs all the common woodworking operations on stock of small dimensions with an ease and speed that outstrips handwork and gives greater accuracy

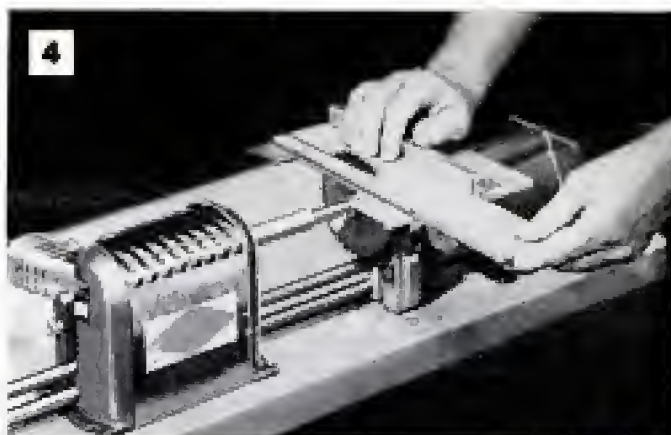

**5. SPRING SASH BALANCES** designed for easy installation enable the homeowner to replace sash cords with modern spring balances with a minimum of time and effort. Remove old pulley and slip new spring unit in its place, fastening it with screws furnished. Then attach tape to sash with bracket

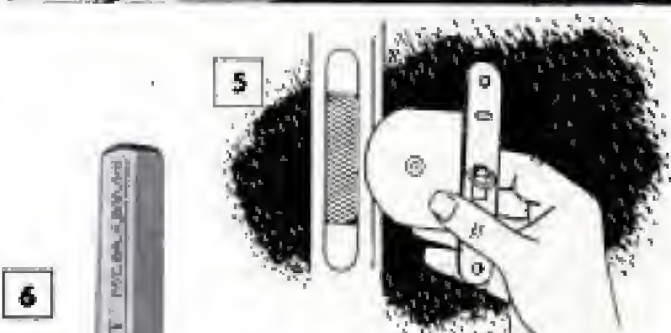

**6. CAM-ACTION SCREWDRIVER** is fitted with a cross pin near the upper end of blade. Pin engages V-notches formed at lower end of handle. In use, driver is placed in screw slot and handle is turned slightly so that pin engages sides of V-notch. Hammer blow on handle tightens or loosens screw



**7. TUNING-SLUG RETRIEVER** has nonmagnetized holder which enables TV repairmen to withdraw slug without removing chassis. When contact is made with screw slot in slug, pressure on handle of tool seats locking pin, enabling operator to withdraw slug and relocate it in proper tuning position



**8. MITER BOX** for carpenters and hobbyists consists of two triangular members formed from heavy-gauge steel. One extended side on each member has a die-formed offset, the two sides forming a guide for the saw blade when the two parts are screwed to a board or bench top as shown in photo



**9. LUBRICATING KIT** contains applicators designed to reach tiny bearings with either oil or grease. Three pencil-size "guns" are supplied, two for light oils, one for grease and also an adaptor which may be screwed onto tubes of cement, glue, grease or other materials for application to small parts



## Grooved Sawhorse Permits Easy Cutting of Building Paper

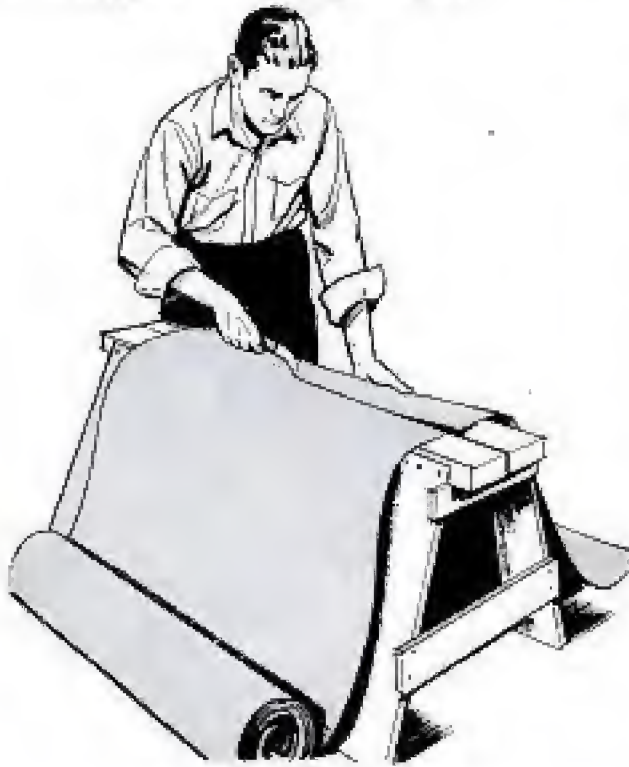

One contractor found that a deep groove, cut lengthwise in the top of a sawhorse, would speed up the job of cutting building paper. The heavy paper, used over sheathing and subflooring, is unrolled and measured to length. Then it is pulled over the sawhorse and cut. The groove holds the knife to a straight line and assures a complete cut with one stroke.

## New Life for Socket Wrenches

If a socket wrench wears so that it rotates on a nut, grind down the end of the socket to remove the worn portion. The recess in most socket wrenches is deep enough to permit this to be done several times and yet still handle most types of work.—Carleton Phillips, Corning, N. Y.

## Padlock Tool-Cord Plug

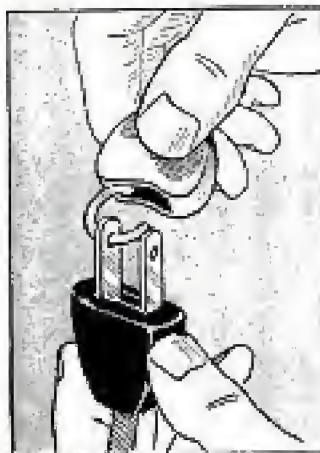

To prevent the unauthorized use of special power tools and appliances which could not be locked up, one shop foreman used a small padlock on one of the blades of the power plug. The padlocks can be purchased at most hardware and dime stores. If the

blades are solid, a small hole can be drilled to receive the loop of the padlock.

P. M. Ohlinger, Portsmouth, Iowa.

## Heavy Iron Floor Stand Steadies Farm Grinder

To reduce vibration and minimize the tendency of a heavy grinder to "walk" on uneven floors, one farmer mounted the grinder arbor on a cast-iron floor stand salvaged from an old cream separator. The stand was bolted to two short hard-



wood planks which serve as skids and provide additional stability. The grinder arbor was bolted to the mounting pad at the top of the stand and the motor mounted below the head as pictured, the drive being through a V-belt and pulleys. The motor mount pivots on one bolt, so the weight of the motor maintains uniform tension on the belt. A flat pulley attached to the outer end of the grinder arbor permits the unit to be driven by a tractor for sickle grinding or other work where electric current is not available.—A. M. Wettach, Mt. Pleasant, Iowa.

## Long Level Improvised From Straightedge

In truing-up fairly long pieces of work, as in form leveling and general remodeling, a level 4 to 6 ft. long is, in many cases, almost a necessity. One can be improvised by attaching a regular 2-ft. level to the side of a 1 x 4 straightedge of hard or soft wood. In fastening the level to the straightedge, it is important to set the level true with the straightedge. The level is fastened to the center with two wooden cleats.

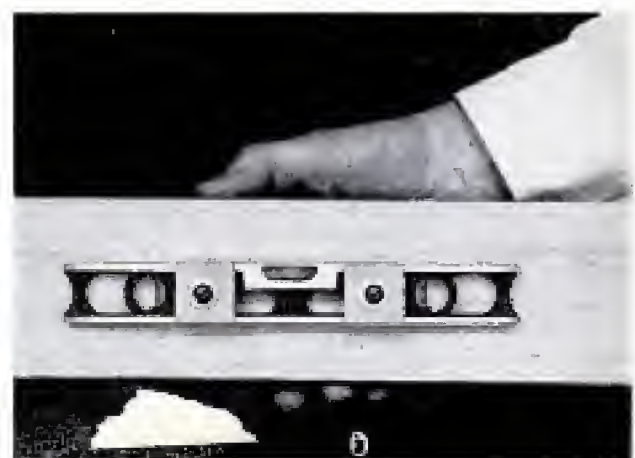

# RADIO *Television* ELECTRONICS

## TV and ELECTRONICS TODAY

SAILORS who built ship models in glass bottles would have qualified today for painting the electrical conductive coating inside large television picture tubes. The General Electric worker in photo A is using a knuckle-handled brush which slides through the neck of the tube and then bends to apply the conductive coating. The technician needs less than two minutes to coat a 21-in. tube.

TV-antenna arrays are now designed for trailers. The one shown in photo B provides the mobile homeowner with a permanent installation which is ready for use at any time. When the trailer is to go on the road, the Trailer-Tenna can be lowered and anchored 2 in. above the trailer roof. Mounted on a telescopic mast, the antenna may be elevated to 7 ft. above the coach top, practically one minute after the parking area is reached.

Using a tape 3 in. wide, the magnetic recorder, photo C now available for commercial use provides continuous recording for periods up to 48 hr. It is expected that it will be employed for radio-program monitoring, police-broadcast and fire-alarm recording. Automatic in operation and unattended, it sounds a buzzer when the tape nears its end.

Personal TV listening is demonstrated in photo D. An ear-type speaker device on a thin 25-ft. cable enables the wearer to view TV and listen to the program on any TV set without disturbing others in the room who prefer to read, sleep or study.



# SUPER-FIDELITY HOME PHONO

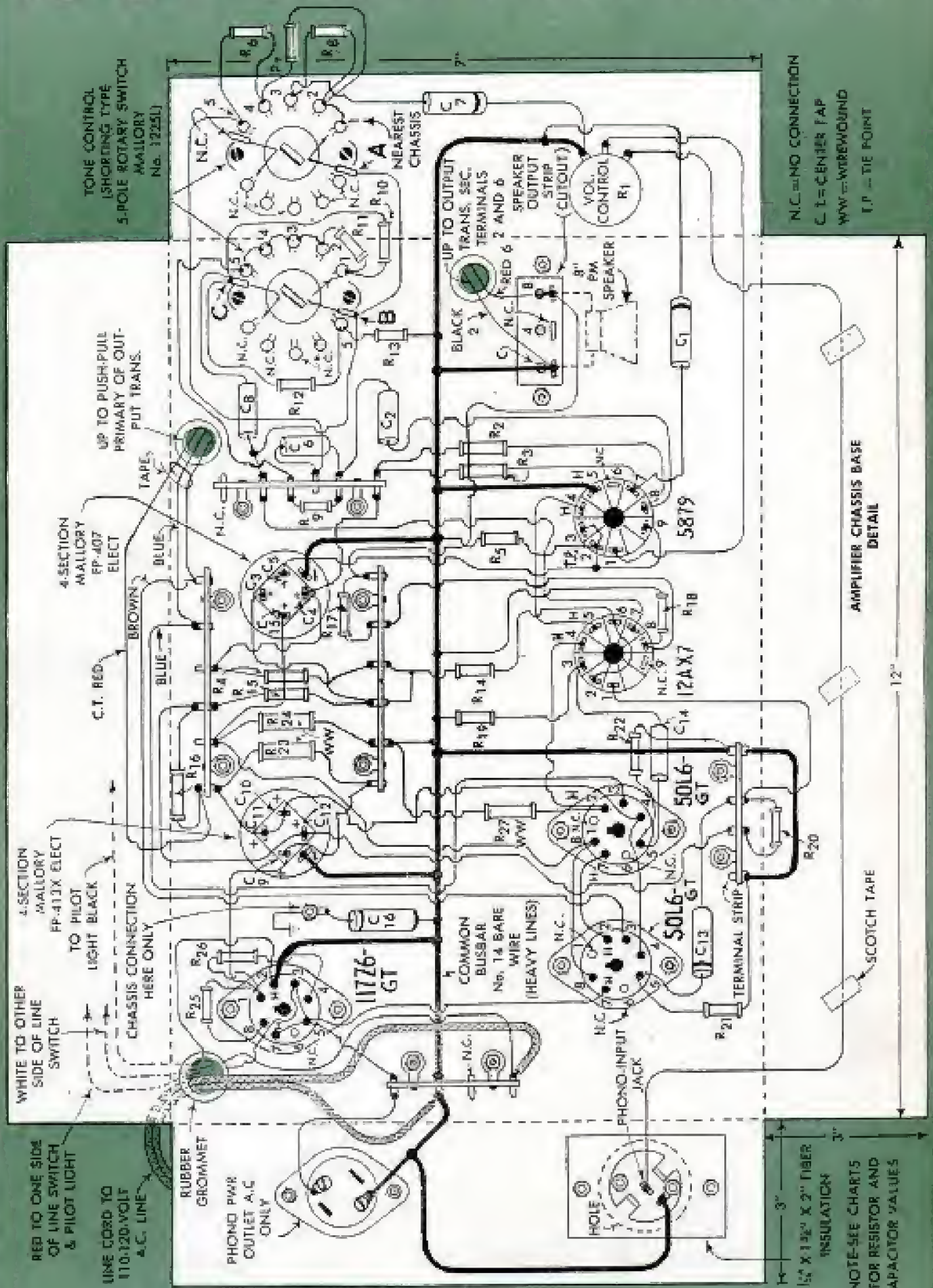

FIG. 1

# HAS BACK-LOADED CABINET...

By Dr. Richard C. Hitchcock

ANSWERING numerous requests for a complete phono system using the super-fidelity principle employed in former *Popular Mechanics* construction articles, this easy-to-build circuit has push-pull output tubes, negative feedback and low distortion at 2 watts output. The tone control is especially versatile and the cabinet is designed so that almost all of the audio energy of the massive 8-in. extended-range PM speaker is actively used. The treble tones come by direct radiation and the bass tones are back-loaded. This feature increases the sound output to more than twice that obtained from enclosed speaker boxes. No sound-absorbing material is used, or needed, in the structure.

This phonograph can be used on a low table or it can sit on the floor as shown in photo A. The height with the lid closed is 26 in., width 17 in., depth 15 in. Made of birch plywood, the complete unit weighs 40 pounds. Using white-pine plywood, it is 30 pounds. The speaker and amplifier are mounted on a single panel as shown in photos B and C. This is easily removed for access to the underside of the amplifier chassis, but all tubes can be changed by

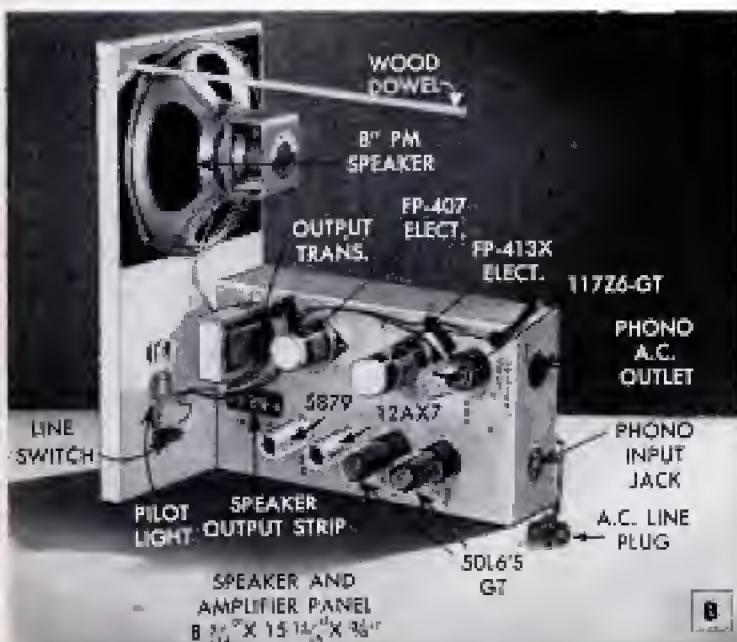

- RESISTORS**
- 1— $\frac{1}{2}$ -MEG OHM (LOGARITHMIC) VOLUME CONTROL PQ-TYPE, IRC OR SIMILAR
  - 2—100,000-OHM,  $\frac{1}{2}$ -WATT CARBON (R2, R9)\*
  - 4—220,000-OHM,  $\frac{1}{2}$ -WATT CARBON (R3, R6, R7, R8)\*
  - 1—10,000-OHM, 1-WATT CARBON (R4)\*
  - 1—2,200-OHM,  $\frac{1}{2}$ -WATT CARBON (R5)\*
  - 2—270,000-OHM,  $\frac{1}{2}$ -WATT CARBON (R10, R11)\*
  - 1—10,000-OHM,  $\frac{1}{2}$ -WATT CARBON (R12)\*
  - 2—4,700-OHM,  $\frac{1}{2}$ -WATT CARBON (R13, R18)\*
  - 1—330,000-OHM,  $\frac{1}{2}$ -WATT CARBON (R14)\*
  - 2—4,700-OHM, 1-WATT CARBON (R15, R16)\*
  - 1—15,000-OHM,  $\frac{1}{2}$ -WATT (R17)\*
  - 2—100,000-OHM,  $\frac{1}{2}$ -WATT CARBON (R19, R20) (MATCHED OR 1% CARBON)
  - 2—470,000-OHM,  $\frac{1}{2}$ -WATT CARBON (R21, R22)\*
  - 2—100-OHM, 5-WATT WIREWOUND (WW) (R23, R24)
  - 1—2,000-OHM, 5-WATT WIREWOUND (WW) (R27)
  - 2—47-OHM,  $\frac{1}{2}$ -WATT CARBON (R25, R26)
- NOTE — \* 10% INSULATED-TYPE RESISTORS

- CAPACITORS**
- 1—0.1 MFD. 200-V. PAPER TYPE (C1)
  - 5—.05 MFD. 400-V. PAPER TYPE (C2, C8, C13, C14, C16)
  - 1—MALLORY 4-SECTION ELECTROLYTIC TYPE FP-407, 30-MFD. 150-V.; 20/20 MFD. 150-V.; 200-MFD. 10-V. (C3).....(C4 & C5).....(C15).....
  - 1—.001 MFD. 600-V. PAPER TYPE (C6)
  - 1—.01 MFD. 400-V. PAPER TYPE (C7)
  - 1—MALLORY 4-SECTION ELECTROLYTIC TYPE FP-413X 40 MFD. 450-V.; 40/40 MFD. 300-V.; 20-MFD. 150-V. (C9).....(C10 & C11).....(C12).....

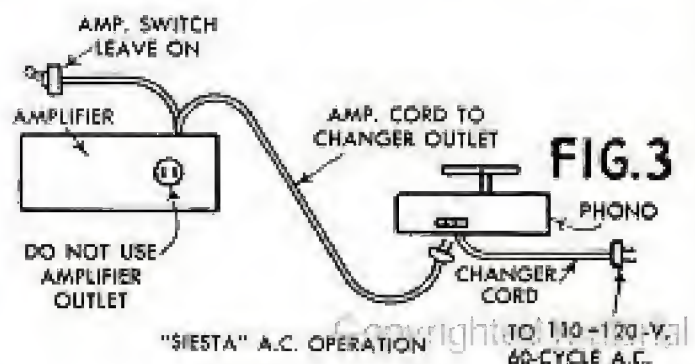
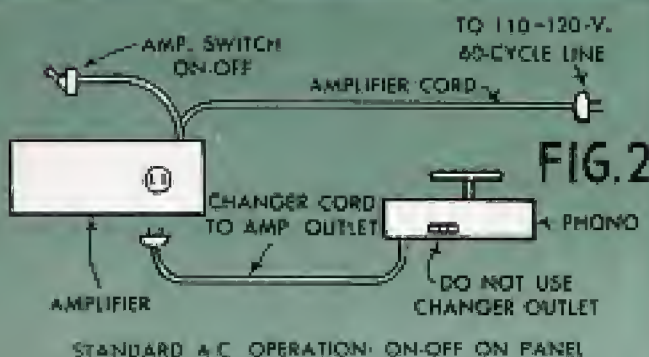

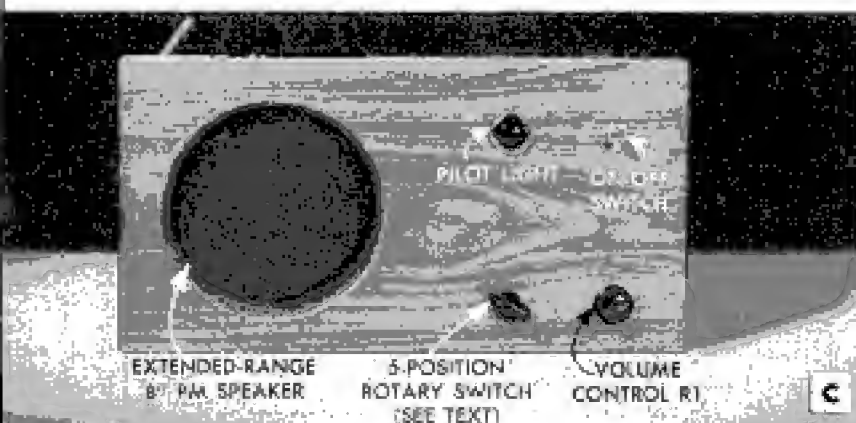
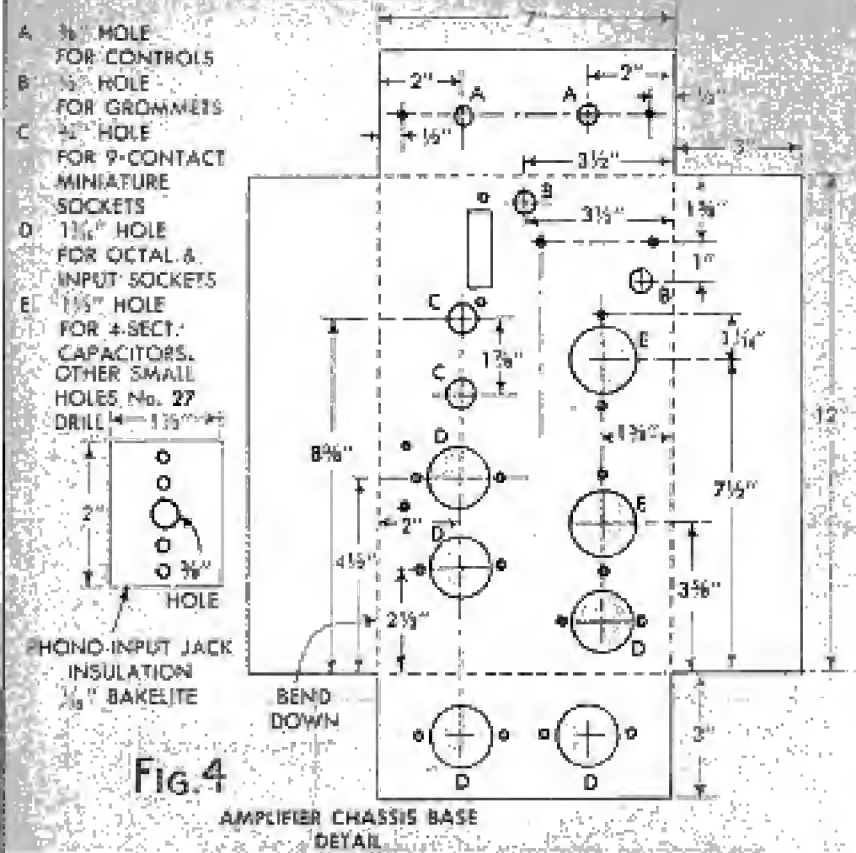

reaching in at the back, as illustrated in photo E.

At 2-watts output the intermodulation output of the amplifier is only 2.8%. An expert can just about detect 5% intermodulation distortion. The tone control has 5 steps: No. 1 is standard bass and standard treble (high fidelity). No. 2 provides bass boost and standard treble; No. 3 bass boost and treble cut (juke-box effect). Step No. 4 will, in most cases, be the favorite as it provides bass boost and treble boost (super-fidelity). No. 5 step is a brand new feature, it provides bass boost, treble boost, plus a cut in middle tones. This is the "conversation" setting. When trying to talk, the loud playing of a phonograph is often annoying. With step No. 5, not only the low and high tones are retained, the middle tones that interfere with conversation are reduced. This is a very desirable feature, one that you will enjoy.

The pictorial wiring diagram, Fig. 1, will aid the inexperienced builder; however, both this diagram and the schematic circuit diagram, Fig. 5, should be checked as the wiring progresses in order to avoid errors. Both diagrams match in every detail. Four audio tubes and a rectifier tube are used. The push-pull output tubes are

(Continued to page 280)

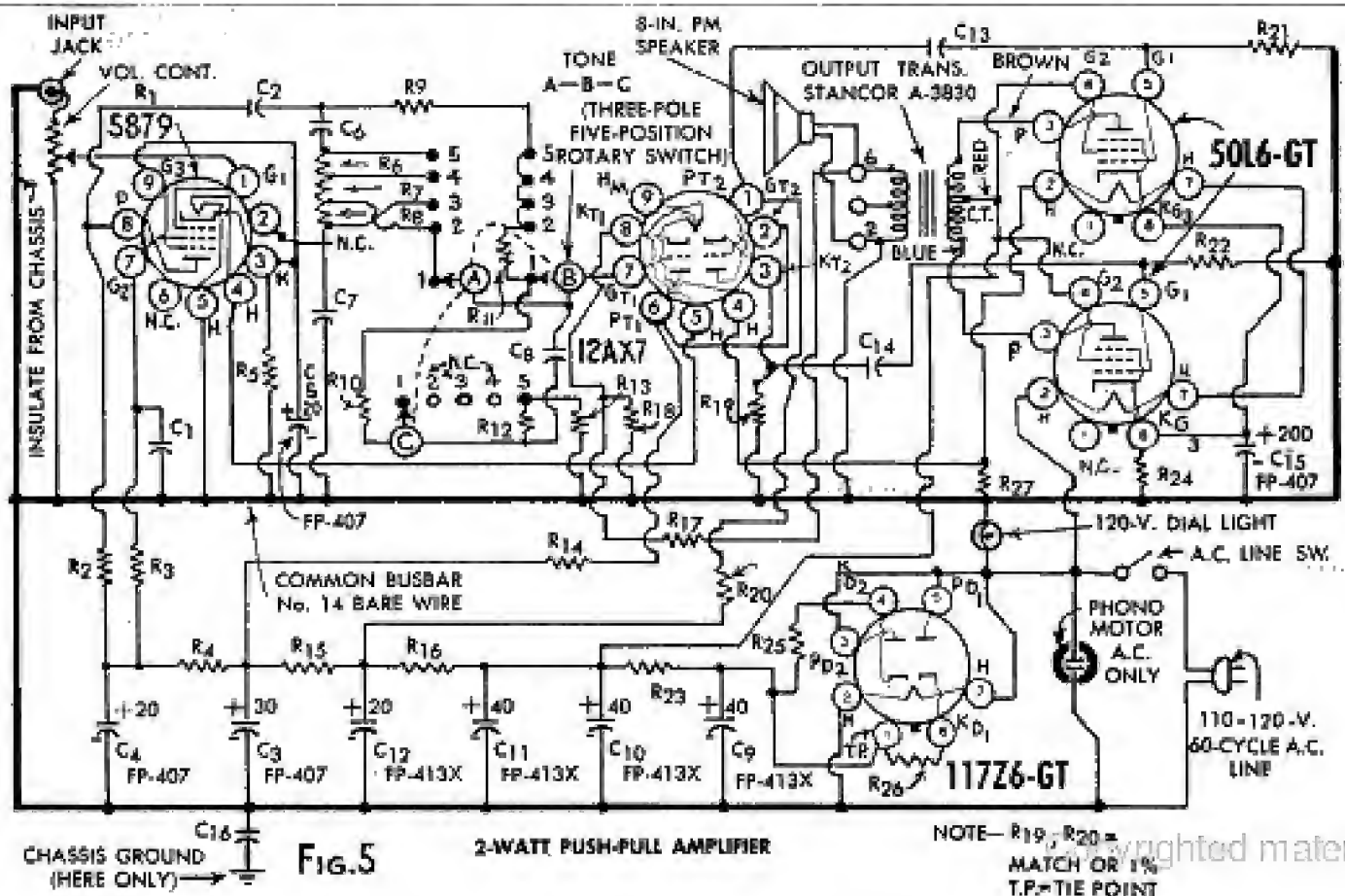



## One sign, one name,

identifies the right parts for your Plymouth, Dodge,  
De Soto, Chrysler, Dodge Truck

The **MOPAR** sign means genuine Chrysler Corporation parts and accessories

Chrysler Corporation provides parts and accessories for all its cars and trucks under one name—MoPar. This name is your assurance of getting parts that fit right, work right, last longer and give greater satisfaction. That is because all MoPar parts are precisely like parts for new cars and trucks—designed by the same

Chrysler Corporation engineers, to meet the same high standards.

You can get any MoPar parts you need from thousands of Plymouth, Dodge, De Soto and Chrysler dealers and from many general service and repair shops. Look for the MoPar sign—always ask for MoPar parts. It pays to be *right!*

PARTS DIVISION

CHRYSLER CORPORATION

DETROIT 31, MICHIGAN

**Kodak**  
TRADE-MARK



## B-C Flash makes sure he gets the picture

B-C stands for battery-condenser. You know what a battery is, of course. *But why the condenser?*

First, let's assume that most of your flash pictures have come out great. But perhaps occasionally a few were *under-exposed* (or didn't come out at all). A weak battery most likely was the cause. It was just weak enough to fire the lamp a fraction late (or not at all, after a few shots had momentarily drained it).

Now—to avoid such possible waste of bulbs and pictures, a *condenser* is substituted for one of the batteries. With this dependable Battery-Condenser system the battery itself doesn't fire the lamp. What the battery does is to feed power to the

condenser. The condenser stores the power . . . always a *full charge* of power . . . and it is the condenser that fires the lamp at just the right instant.

The battery can even become weak: yet you'll get your flash picture. Because the power stored in the condenser does the firing, the battery can be used for a much longer time. B-C is extra-dependable, extra-economical flash. It's a system you'll want to own, whether you've taken flash pictures before or are just about to start.

On the opposite page you see the latest Kodak B-C flash equipment. Your dealer will be glad to demonstrate the advantages of B-C. Be sure to see him soon. Make him headquarters for all your photo needs.

Copyrighted material



# NOW... an economical Kodak B-C Flashholder—\$9.95

You get all these advantages . . . in a dependable B-C unit that fits most cameras with built-in flash shutters:

**50% more light**—New Lumaclad reflector allows you to stand back further, get more subject in picture.

**Sturdy hand grip**—Popular press-type, easy to grasp. Adjustable bracket quickly attached (or removed for off-camera shots).

**Special lighting easy**—Flashholder has connector for multiple lighting with one or two Extension Units (see below).

**Cheap operation**—Uses low-cost midget lamps in standard sizes: 5M, 5F, Nos. 5, 5B, 25, and 25B.

**Easy-to-use lamp ejector**—Simply press release, lamp pops out.

**Handy exposure guide**—On back of reflector, right before your eyes.

**2-Way Flashguard included**—Slips over reflector, gives either normal or "soft" light.

**Special adapters available**—For attaching Flashholder's ASA-bayonet connection to other type flash connectors.

Flashholder also available in Standard model without B-C. Uses "C" batteries; accepts B-C Flashpack (see below). \$7.95.



## For super-versatility with Kodak B-C Flash

The Kodak Ektalux Flashholder fits most press-type and roll-film cameras. Here it's shown at right with 2 extension units—used for special lighting effects (takes up to 6 units).

The Ektalux gives you many exclusive features: quick loading and ejecting for both midget and medium-base lamps . . . two-way focus of midget lamps for uniform or concentrated light . . . convenient exposure guide . . . comfortable pistol grip. You can trip camera shutter from the Flashholder—or convert non-flash shutters. The Ektalux (with magnesium die-cast body) is durable but light; easy to pack (reflector removable). Flashholder with standard bracket, \$29.75.

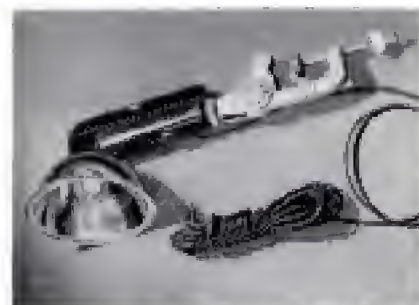
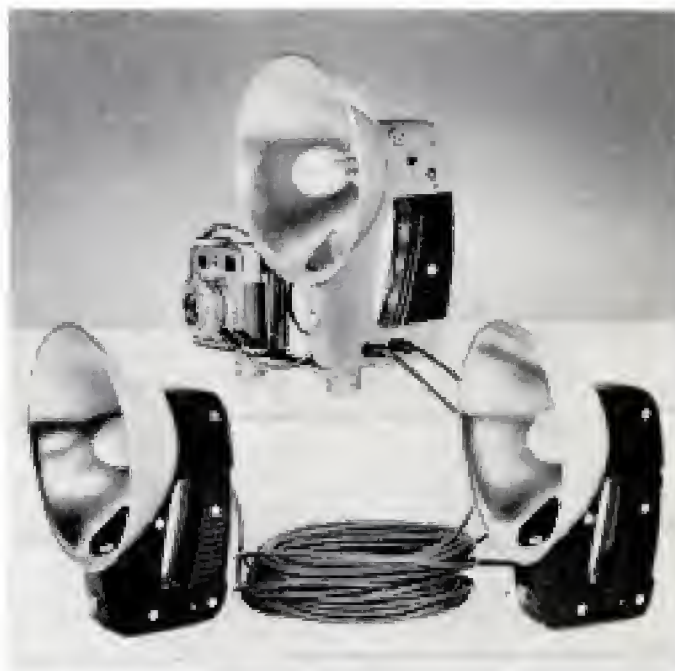

**Take large-area pictures**—Kodak Flashholder Extension Unit, complete with Lumaclad reflector and 20-foot cord, gives extra light to cover large areas. \$11.00.



**Convert other flash units**—Kodak B-C Flashpack replaces two "C" batteries (end-to-end type), converting to dependable battery-condenser power. \$2.95.



**Flash shots with simple cameras**—Kodalite Flashholder for Brownie Hawkeye Camera has Lumaclad reflector. \$4.00. Your dealer has other inexpensive Flashholders, too.

*Prices subject to change without notice*

**Eastman Kodak Company, Rochester 4, N. Y.**

Copyrighted material



# Care and Feeding of Engines

BY S. P. CORP

## COLD WEATHER OIL CARE

Winter's shorter trips and slower speeds tend to keep down engine temperature. The engine doesn't get hot enough to vaporize water that has formed in the crankcase, and so sludge accumulates. Change oil more often, and be sure to check the ventilating system of the engine.

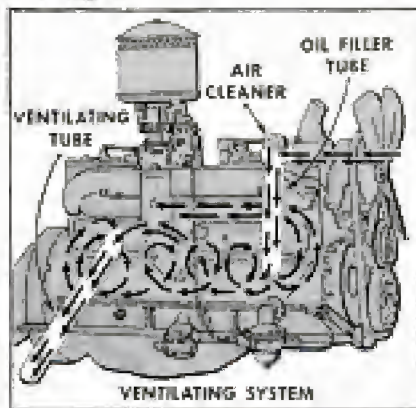

Remove and clean the ventilating cap at the top of the oil filler tube, using kerosene to remove all dust and foreign matter which might obstruct free movement of air into the engine. There is also a ventilator tube at the rear of the engine, extending down below the engine

and visible from under the car. Remove the clamp or bolt at the top of this tube, clean tube, and look to be sure it is not bent or damaged.

Proper ventilation depends on correct engine operating temperature. Therefore it is important to see that the gauge on your instrument panel shows 160 to 180 degrees. By warming the engine up to this temperature before starting out in cold weather, you will help keep condensation from forming in the crankcase.

## FOR EASIER STARTING

Dirty batteries cause hard starting. Clean any white sulphate from connections by brushing with an ammonia or soda solution, washing battery with clean water after foaming has stopped. To delay further corrosion, spray battery terminals with Sealed Power Dry Film Lubricant. Be sure that water is above plates in each cell, then check charge with a hydrometer. All cells should read between 1.275 and 1.300. If all are down to 1.225, battery needs charging. If one cell is down more than .025 points, you may need a new battery. An open circuit voltage tester across the two terminals should read 6 volts plus.

## WRITE FOR FREE BOOKLET

Insist on Sealed Power KromeX Ring Sets, with the famous MD-50 Steel Oil Ring, the only ring with the Full-Flow Spring. Invest two cents in a postal card to ask for your free copy of "MORE POWER, Less Gas, Less Oil." It may save you a lot of money. Address Sealed Power, Dept. G-2, Muskegon, Mich.



# Clinic for Homemakers



As a service to our readers in solving the hundreds of problems pertaining to a home—inside or out—the editors of *Popular Mechanics* invite you to present your problems to The Clinic Editor for help and advice. Address your questions to The Clinic Editor, *Popular Mechanics Magazine*, 200 East Ontario Street, Chicago 11, Ill.

## Waterproofing Wall



**Q**—I'm having trouble with water seepage through the concrete-block walls of my basement. The house is built in a low place from which there seems to be no natural drainage. Water comes through the wall only, not through the floor. Should I try an inside waterproofer or apply it to the outside of the wall?—C. C., Ga.

**A**—Judging from your description the problem seems to have no simple or inexpensive solution. Your question implies that the wall has not been waterproofed either inside or out and that there is no drainage tile at the footings. If this is correct, then it would seem the only procedure offering any possibility of a permanent solution is to dig down along the outside walls to the bottom of the footings and install drain tile leading to a lower outlet, even though this requires ditching to a considerable distance from the building. After laying the tile, the wall should be waterproofed with cement plaster, or better, an asphalt impregnated membrane consisting of two layers of special felt mopped onto the walls with hot asphalt with the edges overlapped at least 4 in. Finish up with a final coat of hot asphalt mopped or sprayed on the surface. The lower edges of the membrane should extend to the bottom of the footing. There is one alternative which sometimes proves satisfactory. This is to lead the drain tile to what is known as a "dry well." In this case the well would have to be dug to a depth at least 4 ft. below the level of the drain tile. Ordinarily, dry wells are dug about 3 ft. in dia. and from 3 to 10 ft. in depth and filled with medium to coarse gravel or crushed stone. After filling, the top of the well is capped to prevent the entrance of surface soil and debris. However, we are doubtful if dry-well drainage would prove satisfactory in your case.

## Filling Concrete Blocks



**Q**—I'm planning to build my own home and thought I would build the basement walls of concrete blocks to avoid the use of forms. I'm thinking also of filling the openings in the blocks with concrete as they are laid up. What is your opinion of this procedure?—V. R., New Hampshire

**A**—Yours is a rather novel idea, although, of course, the procedure is not unknown in building  
(Continued to page 254)

# It's easy, inexpensive to fix up your attic with Armstrong's Temlok



**1. You can turn a dark, dusty attic** into a cheerful bedroom in a few days with Temlok Tile and Plank. Temlok is a durable, inexpensive wood fiber material that builds, decorates, and insulates. First, nail 1"x3" furring on 12" centers to all framing members.



**2. Walls go up fast with Temlok Plank.** The smooth, long planks are easy to handle. Temlok's exclusive Lok-Bevel Joint makes nailing or stapling extra fast. Planks come pre-finished in "Suntan Blend," a random coloring. Sizes: 8", 12", 16" wide; up to 12' long.



**3. Ceilings no problem with Temlok Tile.** Comes factory painted in Snow White and Light Ivory... gives ceiling high light reflection. Lok-Bevel Joint hides all nails and staples, almost anyone can do a neat-looking job in a short time. Sizes: 12"x12", 16"x16", 16"x32".



**4. Job done in a day or two.** Once Temlok is up, move in the furniture, and you'll have a comfortable attic room at remarkably low cost. Your family will be after you to fix up the basement with Temlok next. Get Temlok at your lumber or building supply dealer.

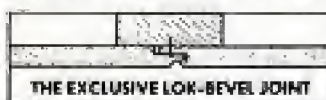

For Free Booklet, "New Ways to Remodel Your Home," write Armstrong Cork Company, 3702 Watch Avenue, Lancaster, Pennsylvania.



## ARMSTRONG'S TEMLOK®

Monowall®

Cushiontone®

Insulating Wool

Hardboards

Counter-top Cement

"Handy" SANDY recommends



these fast,  
**GOOD  
SHORT-CUTS**  
...save and use 'em!

**Quick way to drill** a series of holes to a given depth: measure on the bit the depth you want and wrap a few turns of FLEXBAC® Masking Tape just above that point. Drill to the tape marker. FLEXBAC Tape peels off clean when you're finished. Keep a handy roll in your shop . . . another in the house. It has dozens of uses.

**Make a set of sanding boards** for quick, easy finishing on small jobs. Cut five 9 x 12 pieces of plywood. Drill a  $\frac{1}{4}$ " hole about  $\frac{1}{2}$ " from the end of each board — centered on the 9" width. Glue a sheet of CARBORUNDUM® Brand Emery Cloth on one side of each board — a different grit size on each, of course. Use a "peel-it-off" cement to make replacement easy. Do the same on the other side of each board, but use sheets of CARBORUNDUM® Brand Flint Paper for wood sanding. Hang 'em on nails near your workbench — you'll use them often. Emery Cloth and Flint Paper by CARBORUNDUM are sold by your hardware or lumber dealer in five handy grit sizes: Extra Fine, Fine, Medium, Coarse, and Extra Coarse.

**Easy-as-pie** way to store sanding discs: just "borrow" a pie tin from the kitchen. Cut it in half . . . tack the rim to a wall or the back of your bench, open end up. Return the unused half to the house, if you dare . . . on second thought, better make two storage "racks".

**Or you can make a trade** with your wife — the pie tin for a sheet of Fine Emery Cloth by CARBORUNDUM. Tell her a few stitches in it now and then with her sewing machine is the best way to keep the needle sharp and efficient . . . make sewing easier.

**Make window screens** this easy way: cut the screening to size and flatten as best you can. Then fold strips of FLEXBAC® Masking Tape evenly over each edge. Gives you an excellent grip for stretching the screen tight . . . holds better when you tack it. Molding will cover the tape. Ask for FLEXBAC Masking Tape by CARBORUNDUM . . . at your favorite hardware store or lumber yard.

**Glue a strip** of medium grit Emery Cloth by CARBORUNDUM to the straight-edge of your circular saw miter gauge . . . keeps wood from slipping while you're cutting.

If you'll send a postcard asking for it, I'll mail you a copy of my pamphlet, "HOW TO SAND", without charge. Tells how to do professional refinishing on furniture . . . has lots of good advice on sanding generally. Address your request to me—



"Handy" SANDY  
**CARBORUNDUM**

REGISTERED TRADE MARK

Niagara Falls, New York

20-45

(Continued from page 252)

construction. We know of no reason why it cannot be carried out with concrete blocks of standard size, that is, if you wish to put in the extra labor and time it's going to take to build the wall in this manner. It would seem to us that one possible objection, especially if you work alone and intermittently, is the fact that you would have in effect several batches of concrete in each wall, each batch poured at a different time. As a result you would have new concrete poured onto that in a partially or fully cured state all the way up the walls. Of course, this would depend on how the walls were built. If you are situated so that the block walls can be laid up to a full height and then the openings filled at one time with a single batch of concrete, we believe this would be the best procedure. We think it would be advisable to plan carefully the construction so that pouring of the concrete can be carried out as rapidly as possible. One thing to keep in mind is that the footings must be of the size normally used under a monolithic (poured) concrete wall of the same height.



#### Loose Hinges

**Q**—The upper hinge in an outside door is loose, permitting the door to bind at the bottom. I've tried to fix it by driving wooden plugs into the screw holes, but they don't hold, even when I used glue. I can't use larger screws as they won't seat far enough into the hinge. Is there any other method?

R. P., Ind.

**A**—Have you thought of drilling holes into the edge of the jamb so that they cross the screw holes at right angles and then driving in short lengths of dowel? Usually this trick works satisfactorily and proves to be a more or less permanent repair. The first thing to do is remove the trim piece so that transverse holes for  $\frac{3}{8}$ -in. dowels can be drilled at the center of the exposed edge of the jamb. Be sure that the holes you drill center across the screw holes. Then drive lengths of dowel in the holes and drill a small hole through each dowel to prevent splitting as the screw is driven in. Another way is to cut a piece of  $\frac{1}{2}$ -in. soft aluminum to the same size as one leaf of the hinge. Using the leaf as a template, drill holes in the aluminum plate slightly smaller in diameter than the outside diameter of the wood-screw threads. Place the drilled plate on the back of the jamb. Then drive in screws of sufficient length to reach through the jamb and the plate. The screws will cut their own threads in the soft metal and draw the plate tight against the jamb, holding the hinge leaf securely in place.

#### Soundproofing Walls and Ceilings

**Q**—I want to soundproof walls and ceilings in two rooms of a house I'm building. The rooms are quite large and one wall in each room is an outside wall. I'm told that there is a special soundproofing tile that can be applied to walls and ceilings right over the plaster. However, I would prefer a smooth plastered wall. Isn't there some way that this can be done? — M. A., Kans.

**A**—Where the walls are yet to be built, it probably is best to install a more conventional soundproofing in the three interior walls of each room. Acoustical tile are quite effective in soundproofing a ceiling and the installation is considerably more economical. In planning, it should be remembered that the walls constructed with soundproofing will be about 3 to 3½ in. thicker than regular. In the installation, the studs are staggered on 16-in. centers, the offsets being about 1½ in. to permit a cellular-soundproofing material or a blanket-type insulation to be woven between them. The former is the best material to use, but the latter is a satisfactory substitute. This type of wall construction eliminates direct contact of the facing materials through the studs, that is, facing materials attached to alternate studs on one side of the wall do not contact the studs to which the facing materials on the opposite side of the wall are fastened. This construction prevents transmission of ordinary sounds through solid materials in the walls.

# "We took a tip from the auto industry to give you a new kind of drill"

says Paul Jones, President, Cummins-Chicago Corp.

There's an amazing story behind Cummins Ball-Rite 44. It revolutionizes  $\frac{1}{4}$ " drill performance.

Until we invented the Ball-Rite principle the craftsman either had to pay a very high price for industrial quality drills—or buy low priced drills that did not meet the performance desired.

We knew that if industrial quality drills could be produced in volume and certain production and engineering prejudices eliminated, their price could be brought down so low that everybody could have their super performance and long life. The answer was to build a product that met industry's high performance standards and produce it at a price that everybody could afford.

The early automobile manufacturers had pretty much the same problem. It was the legendary Ford that combined in one automobile the stamina and durability required by business with a price level that made the automobile the every-day necessity of every family. When the tremendous sales volume of these two markets was combined in one product, sales soared and true mass production was born.

Now, that's exactly what has been accomplished with Cummins Ball-Rite drills. We designed the drill for industrial use and the Ball-Rite 44 today is being used in airplane, automotive and manufacturing industries side by side with drills costing one-third more. Then, by using continuous conveyor belt assembly (instead of the old bench method) we were able to rev production up to hundreds a day and produce the same drill within the price range of the ordinary home-type drill. Instead of having to sell this new Ball-Rite 44 above \$40, we were able to price it at \$29.95. Both industry and the home user benefitted.

Actually, Cummins took a tremendous gamble in setting up huge volume production lines, but we did it with the confidence that if it could happen in the automotive industry it could happen in the drill business. Our gamble paid off. Both you, the consumer, and industry, bought the Ball-Rite 44 because it gave you performance you would never have been able to touch before at the price.

Every Ball-Rite drill carries the Ball-Rite tag giving its basic industrial specifications. As far as we have been able to find out, it is the only drill on the market carrying a printed tag describing its basic qualities. Here's the tag:



## WHAT BALL-RITE MEANS TO YOU

Ball-Rite Construction is a combination of the finest specifications in an electric tool and includes:

1. Ball Bearings in the right places.
2. Always Hardened Gears.
3. Always Double-Coil Motor (type always used in industrial drills).
4. Always Dynamically Balanced Armature for smooth flowing power.

So, before you buy any drill get a Ball-Rite 44 into your hands and switch it on. You will feel smooth, abundant power that can only be matched in \$40 industrial drills. That power in the 44 drills  $\frac{1}{4}$ " in metal in its stride, handles 1" drilling in all kinds of wood, and with carbide tip drills, drives up to  $\frac{1}{2}$ " holes in concrete.

Say, you know we even use this Ball-Rite 44 drill to power the famous Cummins **do-it Shop**... that combines the 7 most wanted home workshop tools in one. The 44 is the only drill with enough power to handle all the jobs we ask it to do in the **do-it Shop!** To give you an even better picture of this drill's tremendous power, I will be happy to send you a free copy of the beautifully illustrated and interesting "Cummins **do-it Shop** Booklet." This will show you the many time and money-saving operations you can perform when you own a Ball-Rite 44 drill. Please write to me for your free copy today.

The Ball-Rite 44 is sold not only by industrial distributors selling to industry but in your local hardware store. We hope you will be one of the first in your neighborhood to own one of these amazing new drills, to learn the real satisfaction and performance you get from every one of Cummins popular priced, top quality tools.

Sincerely,

PRESIDENT

CUMMINS-CHICAGO CORP., 4740 N. Ravenswood Ave., Chicago 40, Ill. In Canada: 334 Laurier Ave., Toronto 10.  
Makers of MAXAWS, MAXDRILLS, BALL-RITE, PERM-ALIGN DRILLS, FIXMASTER KITS, DO-IT SHOP  
Copyright 1954, Cummins-Chicago Corp.

(ADVERTISEMENT)

BEAUTIFUL, MODERN  
**Bruce PREFINISHED  
 Oak Floors**



Your choice of Block,  
 Strip, or Ranch Plank

**Easy to lay right over  
 your old floors  
 ...no sanding or finishing**

Now it's easy and economical to give your home the new beauty of modern oak floors . . . with all the glamour of nationally-famous Bruce Prefinished Hardwood! In only a few hours, your living room, bedroom, dining room—or that unfinished room upstairs—will glow with a style as modern as tomorrow. You can choose Block, Strip, or Ranch Plank design.

**It's EASY!** These floors are completely finished—even waxed—at the factory. Just cover old floor or smooth subflooring with felt paper and nail down this highest quality oak. No sanding or finishing . . . no mess or smell. Ready for use as soon as it's laid . . . and your home will have the rich style and lasting beauty chosen by leading interior decorators.

**It's ECONOMICAL!** A new Bruce Hardwood Floor will cost you less than a good rug or carpet . . . and will last the life of your home. The famed Bruce "Scratch Test" proves this durable finish doesn't scratch, chip or mar. Ask your lumber dealer for an estimate. Mail coupon below for colorful literature.

**MAIL FOR FREE LITERATURE**  
 E. L. Bruce Co., Box 397-R, Memphis 1, Tenn.  
 Send me complete, free information on prefinished Bruce Hardwood Floors.

Name . . . . .  
 Address . . . . .  
 City . . . . . State . . . . .

**Bruce**  
**Bruce Hardwood Floors**  
 Product world's largest hardwood flooring maker



**Oklahoma Drive-In Library  
 Features Curbside Service**

In Oklahoma City, Okla., you can order your library books by phone, then drive down and pick them up without getting out of your car. After receiving your card, the attendant at the drive-in window places the requested books in a movable drawer which slides out toward the car for emptying. Books to be returned are dumped into a curbside box.

**Bidding Wheel**

Bridge players have the Goren system of bidding at their fingertips in a compact bidding wheel. The arrow on the wheel is set at the response you want to know. The correct bid is read in the window of the wheel. The Goren point count is listed on the back of the card.





# Texaco Tips

## on car care



### How to get good automatic transmission performance

If the level of your automatic transmission fluid is below normal, you can't enjoy smooth, efficient motoring...and you may run into expensive repairs. See your Texaco Dealer for Texamatic Service. He has taken a special course in automatic transmission care. He will check the fluid level. If it is low, he will add the precise amount necessary. At the mileage specified by your car manufacturer, your Texaco Dealer will drain and refill your automatic transmission with Texaco Texamatic Fluid as required.

### How to get longer engine life

Today's best motor oil is made...not born. Nature's finest oil failed to meet the tough requirements of today's high-horsepower engines. That's why Texaco engineers developed *Advanced Custom-Made Havoline*. Its Balanced-Additive formula gives your engine the all-around protection against wear that it needs. The results of rugged tests show that tappet "A" was "dished-out" after 100 hours of operation with a good heavy duty oil. Using *Advanced Custom-Made Havoline* for 500 hours, tappet "B" showed no sign of wear. Get *Advanced Custom-Made Havoline*—the great motor oil that protects against rust, keeps your engine clean, free from sludge and metal-eating acids... actually wear-proofs your engine for the life of your car. See your Texaco Dealer... the best friend your car has ever had.



CHANGE TO *Advanced* CUSTOM-MADE HAVOLINE  
... the best motor oil your money can buy

THE TEXAS COMPANY  
**TEXACO DEALERS**  
in all 48 states

Texaco Products are also distributed in Canada and in Latin America



TUNE IN: METROPOLITAN OPERA radio broadcasts every Saturday afternoon. See newspaper for time and station.

**NEW for Your Workshop!**

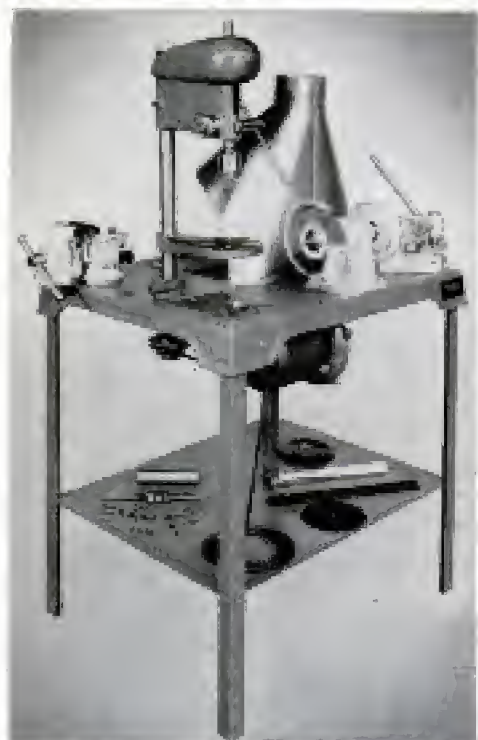

**Original  
•  
Complete  
•  
Ready  
to  
Use!**

**Only  
\$269.50**

F.O.B.  
Lancaster, Pa.  
Ship. Wt. 240 lbs.

## The Champion **FORGE SHOP**

**Works Iron, Sheet Metal,  
Aluminum, Brass for**

**Homeshop, Farm, Factory  
Estates, Repair Shops, etc.**

Includes: 1/3 h.p. Motor; 15" x 20" Forge with air blast regulator; electric blower; 3 1/2" machinists vise; 14" two speed radial bench drill press; Grinder & Polisher with emery, cut-off, polishing and wire wheels; 3" lever operated Shear; Hammer; Fire Tong; Tap Wrench; Set of 1/4", 3/8", 1/2" taps and drill bits to match; 1/2" steel burr; complete assembly & instruction book.

**Make your own furniture, signs,  
railings, trellises, repairs, etc.**

See the **FORGE SHOP** today at your hardware store or Hobby Shop—OR write for Free Catalog to Champion Blower & Forge Co., Dept. P, Lancaster, Penna.

Name \_\_\_\_\_

Street \_\_\_\_\_

City \_\_\_\_\_

State \_\_\_\_\_



### Hand-Built Car

Stepping to the front of American automobile designers is LeRoy Freck, a Hillsboro, Wis., man who has incorporated the latest automotive advances in a natty sport roadster. Freck's hand-built model features wire wheels, unhampered visibility on front and sides, and a turning radius smaller than the most maneuverable Continental cars. His answer to power steering is a simple hand tiller which does away with the conventional arm-wrenching steering wheel. The no-glare headlights, secured from a turn-of-the-century surrey, are fueled by kerosene. An added safety feature is the elimination of the windshield—Freck reasons that you're not likely to exceed the speed limit with a gale in your face. The excellent brakes, the steering gear and frame of the car were fashioned by hand. An old buggy top and war-surplus wheels helped to complete the custom model. The motor, taken from a power saw, has driven the automobile at speeds approaching 18 miles per hour. If the final result looks to you like a 1903 horseless carriage, Freck says, it's just because you're behind the times.

### Radiant-Glass Heating Panels

Radiant-glass heating panels—glass plates with a metallic coating on their backs—solve a space problem in small bungalows. Operating on 115 or 230-volt household current, the panels are backed by reflectors and positioned beneath windows. Current flows through the metallic backing, generating heat which is thrown out into the room. A total of 10 1000-watt panels kept a four-room test house comfortable while outside temperatures hovered between zero and 32 degrees Fahrenheit. Cost, however, was more than heating by conventional methods.



# GRAVELY



CULTIVATE



MOW WEEDS

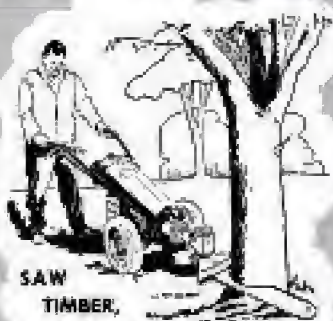

SAW  
TIMBER,  
FIREWOOD



MOW  
LAWNS



BLOW  
SNOW



MOW  
LAWNS, WEEDS,  
MULCH  
LEAVES



HAUL

**MAIL TODAY**



**More  
for your  
Money!**

## GRAVELY MAKES TOUGH JOBS EASY!

Gravelly does jobs other tractors won't . . . because Gravelly has that *extra* power you need for the tougher mowing, gardening, field and farm jobs. Does a better job, even on *steep slopes!*

You get *more* when you get Gravelly. All-gear drive, power reverse, simple operation. More traction from easy-handled, *balanced* weight. Power attachments quickly interchanged, *securely* mounted, with only four bolts!

See Gravelly's rugged, compact, completely functional design. Not merely assembled, but completely manufactured by specialists who make only Gravelly Tractors and their attachments.



5-HP

SINCE  
1922

## PLUS . . . 21 JOB-RIGHT TOOLS!

Your choice of 21 tools for a versatile tractor that saves time, work and worry *all year long*. Tools to do every mowing, gardening, field and farm job.

Send coupon today for "Power vs. Drudgery", the big booklet that shows how Gravelly equipment solves your upkeep and gardening problems . . . *faster, easier, better!*

**GRAVELY TRACTORS, INC.**  
BOX 263 DUNBAR, W. VA.

Please send me "Power vs. Drudgery" Booklet and dealer's name.

NAME \_\_\_\_\_

ADDRESS \_\_\_\_\_

CITY \_\_\_\_\_ STATE \_\_\_\_\_



make that small room larger

with **SPACEMASTER** folding doors

only **\$24<sup>95</sup>** 2'6" x 6'8½" opening  
\$1.00 higher in far west

When you replace space-stealing hinged doors with a steel-framed vinyl-covered "Spacemaster" folding door, you actually make rooms larger. "Spacemaster" folds within the doorway... frees the area around the door... gives you extra room for a chair, table, cabinet or desk. And you can install "Spacemaster" yourself, in just 15 minutes.

Here's How Easy It Is



**STEP 1.** Slip door on head track, screw track onto header.

Nothing more to do. Door's in! No hardware to set. No painting or finishing—ever!



**STEP 2.** Screw 4 jamb clips to jamb and snap jamb post over them. That's all.

SIZES	
Full Opening Width	Opening Height
up to 2' 6"	6' 6" or 6' 8½"
up to 3' 0"	6' 6" or 6' 8½"
up to 4' 0"	6' 6" or 6' 8½"
Doors may be used in pairs.	

Ask to see "Spacemaster" at your local lumber or building supply dealer's today.

**SPACEMASTER** folding doors  
by

NEW CASTLE PRODUCTS, INC.

New Castle, Indiana

In Canada:

New Castle Products, Ltd.

Montreal 6



Copyrighted New Castle Products, Inc., 1954

## The Iron Road to Labrador

(Continued from page 124)

Mont Joli on the Gaspé Peninsula, Hoyt still flies back and forth, trouble shooting and "building fires" under people to "keep 'em loaded and keep 'em flying." The freight-switching point is now at Mile 134, where completed rails bring in carloads of everything from eggs to power shovels for the planes to tote the rest of the way.

The ready shack beside the strip is a madhouse of confusion. Pilots stand by waiting for regular crew shifts. Upstairs the radio crackles and squawks above the wind. Somebody at Knob needs a generator. Menihék is out of fuel oil. A 20-ton tractor broke down at Ross Bay (Mile 224). Clerks relay orders. The ETA board is in a state of continual revision. Outside, another thunderstorm is whipping the strip with an ice-water deluge. In a minute the sun will shine. Big planes roar in and out, heedless of the rain, filling special orders and running routine loads on ceaseless round-the-clock duty that stops only for repairs or regular check ups.

The planes have carried some notable loads. Into the maw of one went 41,000-pound track-driven loaders, 39,950-pound tractors, massive 2½-yard shovel scoops. Biggest load was a gigantic motor crane that weighed 60,000 pounds and had to be cut up and rewelded on the site in order to fit into the big ship.

Massive sections of machinery still fly this way out of Mile 134, under the watchful eye of Howie Robinson whose job it is to see that men and materials move out in a steady flow. Oddly, the cargo that crews hate most to carry sounds like a simple one—ordinary cast-iron pipe. "You can't tie it down," explains Robinson. "It shifts and slips." One of the two planes lost since the airlift began in 1948 was a DC3 with just such a cargo. Half the pipes slipped back from the middle of the load during take-off, dragged the tail to the ground and snapped the plane in two with a shattering crash. "Pipes spun and bounced all over the runway," the pilot recalls. The front end of the plane slammed down, went spinning along the strip to a grinding halt and the crew stepped out bewildered but unhurt. The only other plane casualty was a PBY that clipped a submerged rock on a lake landing and sank in 200 feet of frigid water up north. The men swam away from that one.

In spite of the hazards and problems Hoyt's HUT lugged 31,000 tons of freight and 47,000 passengers up and down the line last year. His veteran bush pilots logged some 20,000 hours of flight time. By last

(Continued to page 262)



**20" JIG SAW**

With completely built-in motor. Table tilts to 45°. Built in blower. Blade turns to rip. Available with mitre gauge and rip fence.....

**\$41.50**



**30" TILTING TABLE BAND SAW**

All cast tool of rugged aluminum alloy. 10 by 10 table top. Has excellent locking mechanism.....

**\$49.95**

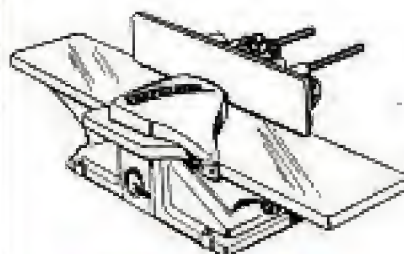

**6" JOINTER-PLANER**

Professional model with latest cutting head. Cuts 1/2 inch deep and 6 inches wide. Removable guard..

**\$86.50**



# Professionals and Amateurs alike rely on Shopmaster

The Most Complete Line of Power Tools in America!



**12" DRILL PRESS BENCH MODEL**

Equipped with Jacobs Chucks, three-spoke feed wheel. Shaper attachments available.....

**\$49.95**

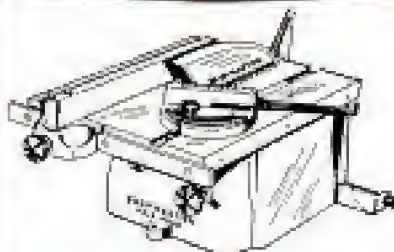

**6" TILTING ARBOR SAW**

Heavy duty construction. Sealed-for-life ball bearings. Table size 13 by 16. Complete with mitre gauge and rip fence.....

**\$51.95**



**9 IN 1 UNIVERSAL TOOL**

Has sturdy workbench stand. Adapts quickly to Circle Saw, Drill Press, Sander, Shaper, Router, Lathe, Jointer, Grinder, or Buffer. All in one tool.....

**\$269.50**

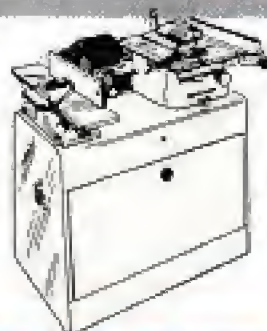

**DUAL CIRCLE SAW-JOINTER**

New combination dual purpose tool, complete with motor that switches easily from one tool to other. Complete with motor.....

**\$154.60**

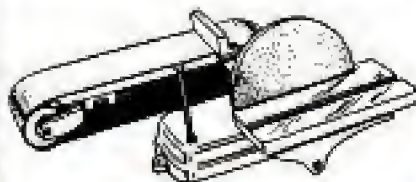

**COMBINATION BELT AND DISC SANDER**

Ruggedly constructed. Table tilts to 45°. Entire sander tilts to vertical position. Has belt tension knob and lock.....

**\$54.00**

Prices slightly lower in Zone 1

**SEND FOR**

**Free Catalog**



# Starrett *Satin Chrome*<sup>\*</sup> MICROMETERS

with FRICTION THIMBLE\*

plus DIRECT FEEL



**STARRETT**  
Micrometer  
No. 231-F  
Range 0-1" by .0001"  
Friction Thimbles also available  
in other sizes and styles

**\* PIONEERED and DEVELOPED by  
The L. S. STARRETT COMPANY**

Starrett Friction Thimble Micrometers give you both friction control and direct feel in a micrometer designed for easy, one-hand use. An improved friction control mechanism built right into the upper portion of the thimble is "right under your thumb" for fast, accurate, repetitive measurements. Lower section of the thimble is integral with the spindle with location and large diameter just right for quick control and "direct feel" on critical measurements.

Only Starrett Micrometers offer you this modern convenience plus 12 other big features. Get them all by insisting on STARRETT Micrometers. Buy through your Industrial Distributor.

## FREE STARRETT CATALOG FEATURING NEW TOOLS

**THE L. S. STARRETT COMPANY**  
Dept. AP, Athol, Mass., U. S. A.



Please send Catalog 26A containing *New Tools* section plus 300 page display of the complete line of Starrett precision tools, dial indicators, steel tapes, hacksaws, band saws, band knives and precision ground flat stock.

Name.....Position.....

Address.....

City.....Zone.....State.....

July he could look back with satisfaction to a grand total of 13,000,000 ton miles flown since the lift began—at a cost that began at 73 cents a pound and is now about 4 cents.

Anything the planes can't bring to the work camps during the five months they operate is hauled in on a "winter road." In winter, with temperatures plummeting to 70 degrees below zero, the vast expanses of water freeze deep enough for three or four months so that mammoth trucks can rumble anywhere. Long trains of "cats" haul sledges carrying houses, rails, ties, drills and derricks up into the wilds. Some have plunged through the ice to be lost forever, but most come through. "Without a winter road," says Jack Little, "half the mines in Canada would never have begun production."

The biggest trouble is muskeg—a spongy mass of decomposed moss that goes down an average of five feet and covers the land like an immense blanket. A walk in the Labrador woods feels like a hike on an inner-spring mattress. In summer, every step brings up a thousand more black flies to join the cloud around your head. Men wear head nets in self-defense. Jeeps and cars bog down in the muskeg and sink out of sight. Even in winter the organic decomposition keeps muskeg from freezing and "cats" plow snow into it to make a road.

To build a railroad over this stuff called for plenty of ingenuity on the part of contracted engineers. They solved it neatly. Skilled dynamiters plant charges in the muskeg. Then streams of 40-ton trucks dump the fill on top. Off go the charges, booming across the wasteland. The muskeg is blasted out from under the fresh soil, which then landslides down into the cavity to hard underlying precambrian rock.

Ingenious stunts are used by the contractors to speed the tracks through. Rails, instead of going all the way to the railhead on flatcars that would have to be shunted to a siding after unloading, are transferred to pairs of rail-car trucks unconnected by any bed, and pushed up to the railhead. Here a big self-propelled crane lifts the rail off the first load, whirls around, lays it on the previously placed ties for crews to bolt in place, and moves up over it. The train of track section moves up behind it. When a load of rail is gone, only a pair of trucks remain on the track immediately behind the crane. These are lifted off the rails, set to one side, and the rail train is pushed up to the crane. At day's end, another crane goes up the track, hoists the trucks back on the rails, they are hauled back to the flatcars for reloading.

(Continued to page 266)

# SCOTT-ATWATER

gives you the outboard that

# bails your boat

Here's the most talked-about outboard improvement in years! The new Scott-Atwater with *Bail-a-matic* pumps your boat dry, keeps it dry . . . automatically!

And *Bail-a-matic* is just one of the exciting features of the 1954 Scott-Atwater line: *Aquablade* Lower Unit, a great new development in outboard engineering; *Pillowed Power* for quieter, smoother cruising; *Stowaway* Gas Tank; *Complete Shift* (forward, neutral, reverse); *Twist-Grip* Speed Control; *Carburetor Drain*; *Remote Control Connections* and many others.

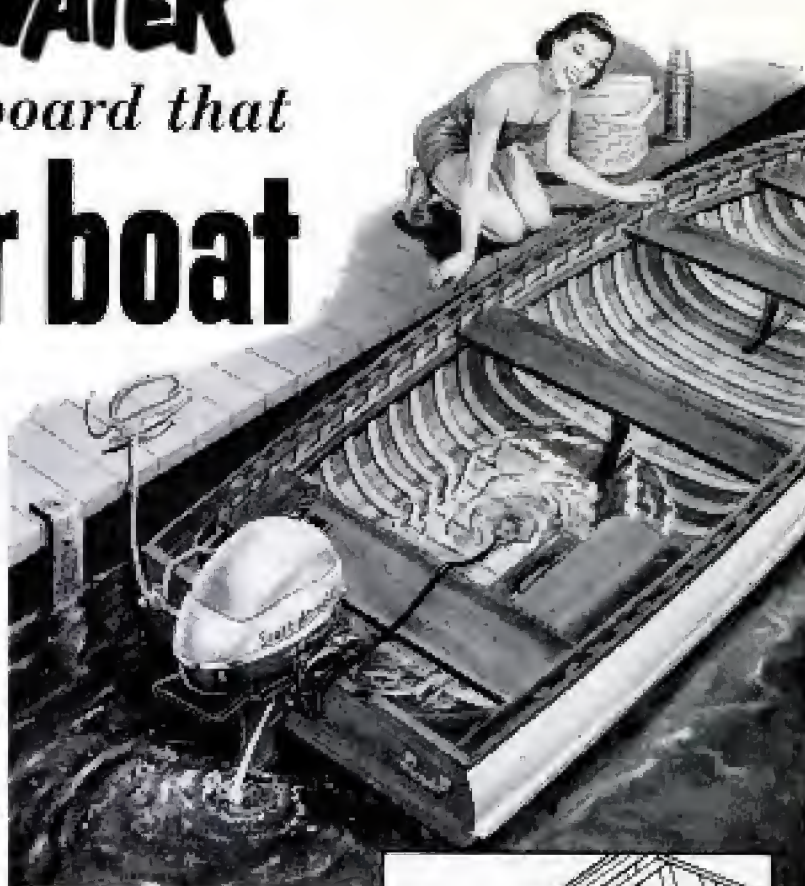

horsepower  
 Certified  
 by U.B.C.  
 F.O.B.  
 factory  
 prices  
 subject to  
 change  
 without  
 notice.

## HERE'S HOW BAIL-A-MATIC WORKS

Water is drawn into screened immersion unit (1), and flows through neoprene bilge hose (2) to vacuum-type *Bail-a-matic* pump (3). The water *does not* circulate through the cooling system; it is immediately expelled (4) via completely separate outlet.

The *Bail-a-matic* unit works at any motor speed, in or out of gear . . . bails more than 150 gallons per hour.

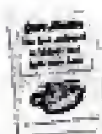
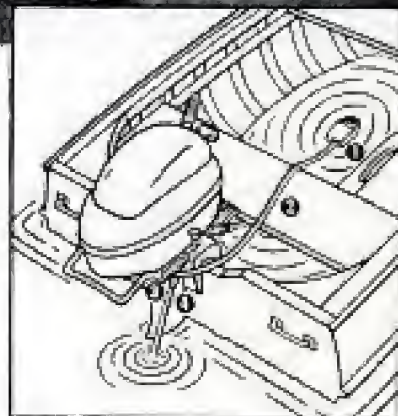

**FREE 16-PAGE BOOKLET** tells the whole story of the sensational Scott-Atwater for 1954. For your free copy, write Scott-Atwater Mfg. Co., Inc., Minneapolis 13, Minn., Dept. X-2. Meanwhile, see *Bail-a-matic* in action at your nearest dealer's. Look for his name in the phone book classified section.

# SCOTT-ATWATER

The first outboard in history that

# bails your boat

SCOTT-ATWATER MFG. CO., INC., MINNEAPOLIS 13, MINN.

FOUR NEW MODELS WITH

## *Bail-a-matic*

5 HP • 7½ HP • 10 HP • 16 HP  
\$269.50 \$329.50 \$379.50 \$529.50

Also, 3.6 HP super single, a powerful, dependable lightweight, and a great value. Only \$109.50.

# What You Could Do With



**DELTA 14" BAND SAW**—used in leading industrial plants for its accuracy, long life, and quick availability of parts and accessories. Built to high precision standards, but not high priced. See it demonstrated at your nearby Delta Dealer's.



Micrometer adjustments of blade guides make possible accurate work, yet allow blade to run free. Guides and blade supports adjust independently.



Big table tilts 45° right and 10° left. Braced by two massive trunnions for maximum rigidity to support heavy work—an exclusive Delta feature.



Height attachment accessory—exclusive with Delta—increases the capacity of your Delta 14" Wood Cutting Band Saw from 6 1/4" to 12 1/4" under the guide.



**Delta Homecraft 10" Band Saw**

Finest saw made for the smaller home shop. Rugged, accurate—cuts 6" in hardwood smoothly. See it at your Delta Dealer, or at leading department and hardware stores.



*DELTA QUALITY MAKES THE DIFFERENCE!*

# This **DELTA** Band Saw!

Make complicated curved cuts easily, in wood or plastic . . . re-saw accurately . . . rip, cross-cut, or miter-cut stock too thick or wide for your circular saw . . . do and make countless things that were before impossible! Once you own a band saw, you'll wonder how you ever got along without it—if it's a *Delta*.

## Delta Quality Makes The Difference

Into every Rockwell-built DELTA Band Saw goes all the experience, the precision-accuracy—all the solid quality—that have made Delta Power Tools leaders for exacting industrial use. In fact, the 14" Delta Band Saw pictured at the left is the same model used in countless modern production plants. It's built to last, simple to adjust, foolproof to handle—and *safe*. Delta-engineered accessories make the versatile band saw even handier to have around, add a lot to your fun and satisfaction, save you more money by allowing you to do more jobs.

Delta quality costs no more than "second best"—so why gamble your money? See the Delta Band Saw demonstrated; ask your dealer about his easy-pay plan. And send the coupon today for helpful Delta literature.

## Hard cuts are easy—on your Delta Band Saw Make dozens of interesting new projects

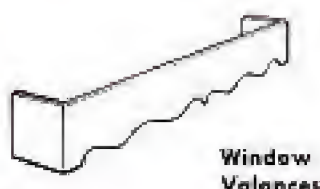

Window Valences

Modern Chairs

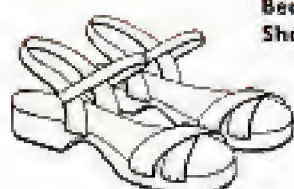

Beach Shoes

Child's Sleigh Bed

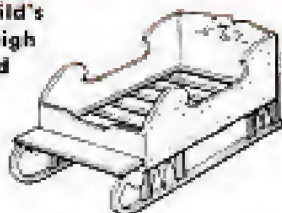

Make hundreds of different curved cuts quickly and easily for professional-looking furniture, toys, etc. Precision Delta workmanship makes it easy to follow lines on difficult cuts.



Re-saw accurately, rip and cross-cut stock too big for other saws. With Delta Height Attachment accessory you can increase capacity from 6 1/4" to 12 1/4" under the guide—an extra offered only by Delta!

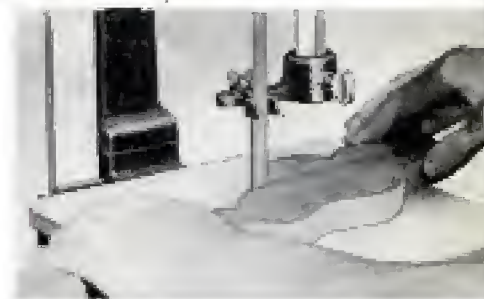

With the handy Sanding Attachment—exclusive with Delta—it's simple to give that all-important professional finish to edges, roll curves and other hard-to-get-at places. Makes your Delta Band Saw more useful than ever.

**DELTA** QUALITY POWER TOOLS

Another Product by **ROCKWELL**



DELTA POWER TOOL DIVISION  
Rockwell Manufacturing Company  
5028 N. Lexington Ave., Pittsburgh 8, Pa.

Please send me:

- New Delta Homecraft Catalog
- Delta Industrial Catalog
- "Getting The Most Out of Your Band Saw" (50¢ enclosed)
- "Things To Make On Your Band Saw" (25¢ enclosed—no stamps, please!)

Name \_\_\_\_\_  
Address \_\_\_\_\_  
City \_\_\_\_\_ Zone \_\_\_\_\_ State \_\_\_\_\_

Copyrighted material

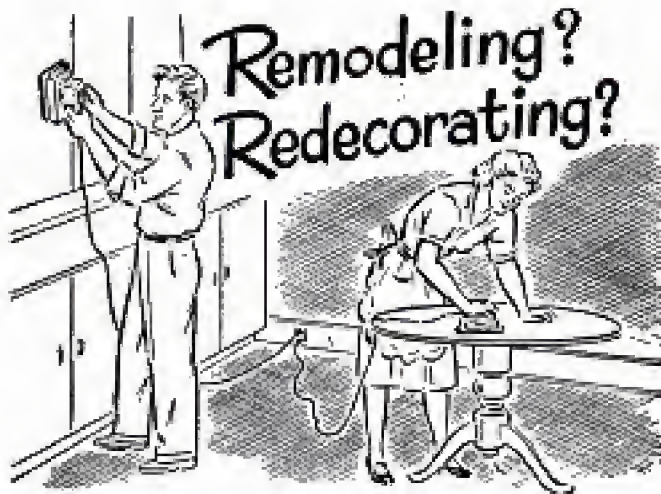

# Remodeling? Redecorating?

## Do it with DREMEL Straight-Line Action Sanders

For the finest finish sanding, take a tip from the professional craftsmen—insist on Dremel Straight-Line Action Sanders. They save you money when you buy them. They save time, labor, and expense when you use them. And they're guaranteed to produce finer finishes because straight-line action sands with-the-grain—prevents cross-grain scratches and orbital swirls. Hobbyist, jack-of-all work, or professional—there's a Dremel Sander for your needs.

Of the four common sanding actions, only Dremel sands 100% with-the-grain — the only guaranteed scratch-free action approved by finishing experts.



### NEW MODEL "53"

This new sander is a real powerhouse, a professional tool kit at a handyman's price. The first DUTY-BY-MOTOR (A.C.) sander of its kind to have straight-line action. Weighs only 5 1/2 lbs., has 24 sq. in. sanding pad. Out-performs other makes selling for twice as much. Positively the best heavy-duty sander buy on the market. Complete with 2 detachable sanding pads. . . . **\$34.85**

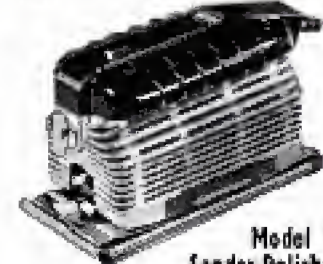
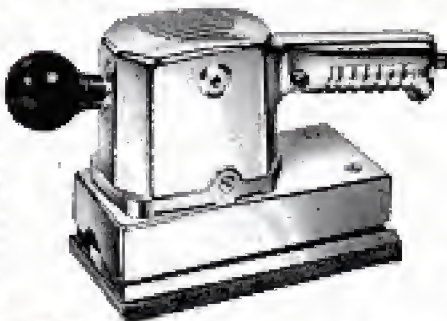

**Model "2000" Sander-Polisher**  
Perfect for small shop, home use. Features Dremel "Straight-Line Action"; high speed reciprocating motor; 14,400 strokes per min.; wt. 5 lb.; 21 sq. in. sanding surface. Price includes: Sturdy, steel carrying case. Model "2000" Sander-Polisher, 1 polish pad, 25 steel abrasives. . . . **\$24.50**

**Model "A" Sander-Polisher-Massager**  
Three tools in one! Lighter capacity for general-purpose use. Features "Straight-Line Action"; high speed reciprocating motor; Wt. 2 1/2 lbs.; 12 sq. in. sanding surface. Complete with 1 polish pad, 1 massage pad, 25 abrasives. . . . **\$14.85**



**SEE YOUR DEALER:** If he cannot supply, order direct on 5-day trial, money-back guarantee. Receipt in full for postal shipment; or send \$2, pay postman balance plus postage and COD.

**DREMEL MFG. CO., Dept. 114-B, Racine, Wis.**

One experimental innovation was the ballasting sledge. After ballast is dumped on the track, rails must be lifted and the ballast tamped under the ties. Hydraulic jacks or big crews of men usually do this job. But on the Quebec, North Shore and Labrador Railway, some wizard invented a steel sledge with a front lip that looked like the end of an aircraft carrier's deck. This was slipped under the ties and pulled by a locomotive, lifting the entire track to the top of the ballast as it goes. "Unfortunately," says Little, "it is not adapted to making the first lift on grades as rough as ours, though it can be used under proper conditions."

Ideas like these, however, are pushing track through at more than a mile each day and are why, come spring, the line will reach Mile 330, where the track will shoot across the back of the 1200-foot Menihok dam. Menihok, which will supply power for the mines, is one of two 10,000-horsepower hydroelectric plants. The other, at Marguerite on the St. Lawrence, will feed electricity directly to the Seven Islands' terminal facilities.

Above Knob Lake, you can see the huge buildings of the new town which will house 500 men and families in neat duplexes. Shops, a big hospital, recreation hall, hotel and waterworks are already in place, ready for the big push in June.

Come June, Jack Little and his bosses can forget the catastrophes and heart-sinking delays that came with the project. Worst was when dynamiters blasting the tunnel through the mountain at Mile 12 blew through the rock roof. Half the mountaintop washed through the gaping hole and down the grade before they could cap it. Test borings had shown thick rock—but between the boreholes the rock took a deep dip no one could have guessed was there.

"Some things we can't do anything about," says Little. "The early breakup of ice at Menihok tore out all our cofferdams and we had to start building the dam all over again. Rock slides at Mile 65 keep busting up the rails, but that stuff has been falling off the mountain for a million years and what are you going to do about it? Spring floods took the entire grade out from under a long section of track last year, leaving the rails draped in midair."

Such are the hazards of getting iron out of Labrador. It's tough—and expensive—to pioneer. The first carload of ore that cascades down the chute in the Seven Islands' dumper house will have cost some \$225,000,000. But IOC won't worry then. The long, winding trainloads of ore that follow will more than make up for it. ★★



mark of the  
true sportoman



Whether they fish in Canada or Florida, swift rivers or placid lakes, true sportsmen know that better gear makes fishing more fun. That's why no fisherman is permanently satisfied with less than the best!

In outboards, that's Mercury — the outboard that has won the respect, admiration and confidence of men who know fine engines — and appreciate "years ahead" engineering and design that make Mercury America's most-wanted outboard!

Move up to a Mercury now! See the 15th Anniversary Mercury line at your dealer's . . . he's listed in the yellow pages of your telephone book.

KIEKHAEFER

# MERCURY mark 20

reverse gear and neutral . . . 16 s.a.e. H.P. Alternate Twin

Write for FREE Illustrated Catalog!

© 1954 KIEKHAEFER CORPORATION, Fond du Lac, Wis.

Features of Mercury motors are protected by issued or pending patents.



- Full Jeweled Power—ball and roller bearings throughout
- Smart, compact design
- Twist-Grip Spark and Throttle Control
- Full-Feathered Safety Steering
- Vari-Timed Valves—automatically correct timing at all speeds
- Waterproof Magneto and Spark Plugs
- Superior Idling—for slower, smoother trolling
- Variable Volume Rawex Water Pump—non-clogging, siltproof
- Uni-Cast One-Piece Gear Housing
- Remote Fuel Tank

**\$372.50**  
F. O. B. Factory



## Floor Surfacing Contractors NEEDED!



- ★ BIG PAY
- ★ FULL or PART TIME
- ★ AGE No Barrier
- ★ Minimum Investment

### Highly Respected Profession Offers You Unusual Opportu- nity to BE YOUR OWN BOSS

Thousands of men of all ages have found financial security and happiness in a phase of the building and remodeling industry that has become as necessary as the hammer and nails. The pay scale is high for those who are willing to work; many earn \$50 a day and more. No great physical stamina required—men from 18 to 80, even with physical handicaps, enjoy this pleasant year 'round indoor work where earnings are limited only by the amount of time you devote to it. The American Floor Surfacing Machine Co., a 50-year-old pioneer firm and leader in the industry, shows you how to quickly make good in this stable business. No schooling, no special talent or skills required. Only small investment in sander gets you started. Send coupon for "money-making booklet" entitled "Opportunities in Floor Surfacing"—enclose 25c in coin or stamps to cover handling.



# AMERICAN FLOOR MACHINES

SEND

The American Floor Surfacing Machine Co.  
535 So. St. Clair St.  
Toledo 3, Ohio

Here is 25c in stamps or coin for booklet "Opportunities in Floor Surfacing", telling me how I can start my own floor sanding business.

Name.....

Street.....

City..... State.....

## Television Joins the Air Force

(Continued from page 137)

because editing and intercutting make the latter more expensive."

Col. Williamson is no amateur, having been in commercial radio and TV for many years before being recalled to active duty in the Air Force. He is as proud of the 1354th's accomplishments as a new father passing out cigars for the first time.

"There are unlimited fields of study," he continues with enthusiasm, "in medicine, surgery, dentistry, first aid and, of course, tactics of war. Without leaving the ground, it would be possible for a student to take a cross-country flight, experiencing vicariously all sorts of weather conditions.

"Teaching is by no means the limit of our potentialities. Through the aid of properly shielded TV cameras we can go into danger areas, physically impossible for the human body to enter, and make scientific studies of extreme heat or cold, of conditions at very high altitudes or in subterranean depths of the ocean. We would be able to creep in closer to an atomic explosion for technical information than man would dare venture. In actual combat, our unit could be used for reconnaissance or spotting enemy action, taking a commander right into the heart of battle scenes in progress. Pilotless planes could be used for photographing difficult terrain behind enemy lines as an aid to the intelligence department."

Outstanding among the "shakedown" projects was the kinescope made of a fire at March Air Force Base, which was not only newsworthy to an interested national-network civilian audience, but was also instructional for continued use in fire-prevention methods.

An old Lockheed T-33 fuselage, with a dummy-pilot victim, was set ablaze, and the waiting airmen in their asbestos suits moved in to demonstrate the latest Air Force fire-fighting techniques in putting it out. Four TV cameras, agile on their rolling casters, caught it all from the first burst of flame to the proposed rescue of the helpless pilot, while sprays of high-pressure carbon dioxide snow and foam iced the roaring inferno to oblivion within 30 seconds. Back in the blue engineering bus, fed by microwave link from the action scene, able technicians captured it all on the intricate, kinephoto recording machinery.

"We intended to rescue our fake pilot," laughs Col. Williamson, "but when one of the real firemen passed out during action, we placed him on the stretcher instead, producing a most realistic, unexpected

(Continued to page 270)

Presenting America's most SENSATIONAL saw VALUE...

**THE NEW**



## 8" TILT/ARBOR, BALL BEARING CIRCULAR SAW

You've never seen a saw with so many value-packed, quality features at anywhere near the sensational low price of the 9310. It gives you the SPEED, ACCURACY, SMOOTHNESS and EASE OF OPERATION that you'd expect only in a high priced saw. Yet it's yours at an almost unbelievable low price with all these important features —



ONLY \$49<sup>95</sup>  
less motor,  
guard, stand . . .  
slightly higher west  
of the Rockies

- TILT/ARBOR CONSTRUCTION . . . with handy, quick-action controls.
- BIG, SEALED-FOR-LIFE BALL BEARINGS . . . long life, smooth action.
- ATLAS DOUBLE-LOCKING LIFT-OFF FENCE . . . full length, with Vernier control.
- BIG CAPACITY . . . 15" x 18" precision ground cast iron table, 2 3/8" depth of cut.
- POSITIVE LOCKING MITER GAUGE . . . accurate, convenient.
- ONE PIECE BASE . . . rugged drawn steel, extra rigid.
- HUSKY STAND . . . with motor mount . . . neat, compact. Optional.
- A HUSKY HEAVY-DUTY TOOL . . . for every operation . . . dadoing . . . shaping molding . . . rabbeting . . . beveling . . . chamfering . . . ripping . . . cross cutting.

See this new ATLAS before you buy ANY saw!

WRITE FOR FREE LITERATURE  
AND THE NAME OF YOUR  
FRANCHISED ATLAS DEALER



*Atlas Press Company*  
254 N. PITCHER ST., KALAMAZOO, MICH.

you can DO so much MORE so much BETTER with *Atlas*

be the proud owner of this  
**IRWIN solid center  
auger bit set**



only \$15.50

13 Irwin Auger Bits  
1/4" to 1" Boring Range  
Beautiful Hardwood Chest

**bore holes easier, faster, cleaner  
... even in hardest woods**

A time-saving, money-saving investment for hobbyist, professional, or handyman alike. Original solid center design for extra stability, extra accuracy, easier boring action. Made of special bit steel, heat treated and hardened full length to stay sharp. Brightly polished for good looks, pride of ownership. Carefully balanced for that good-to-work-with feel.

A practical investment for yourself. Makes a wonderful gift, too. Also available in 6 and 10 bit sets in hardwood chest, colorful plastic roll sets and individual sizes, 1/4" to 1 1/2". See your independent hardware dealer soon. The Irwin Auger Bit Company, Wilmington, Ohio.

Send for  
**IRWIN  
Hang-A-Bit  
Rack**

only \$1.00  
postpaid



Durable steel construction. Easy to mount. Holds 13 Irwin auger bits in special steel clips — individually, firmly. Size-marking for each bit, 1/4" to 1". Send \$1.00 to Irwin, Dept. 1, Wilmington, O. No COD's. Offer applies to USA only. Quantity limited. Order now!

Ask for **IRWIN**  
when you buy

**IRWIN**

the original solid  
center auger bit  
screw drivers  
screw driver bits

touch. Now when some one says, viewing the start of the kine, 'Oh, that's a pretty obvious dummy,' I just wait for the camera to pan down to the live man being placed in the ambulance to make him swallow his words."

In the production end, skilled instructors have trained men to become expert directors, actors, writers, set designers and make-up artists. They even have a wardrobe department where a modest lieutenant may be changed into a German commander, or a captain returned to a civilian role without benefit of discharge. The special-effects boys are busy creating miniature villages and mountain ranges or pulling an explosion or a forest fire out of their versatile cuffs on short demand. In the converted barracks at Lockheed, artists lean over drafting boards, making story sketches, set designs or title cards.

The 1354th Video Squadron has ironed out all the "bugs" and is ready to crawl out of its hangar and set its camera sights on a man-size job. Whether it be routine weather briefings to pilots or behind-the-lines intelligence service from a drone plane over a battlefield, it is ready to take its place as a useful and unique unit in the United States Air Force. ★ ★ ★



**Plastic Tool Pulls Fuses**

Operating on a double-leverage principle, a newly introduced device exerts a powerful pull and holding power when removing fuses. It will pull fuses from the tightest clips without allowing the fuse to slip or twist. Made of a tough, moisture-resistant plastic, the puller has two operating ends to handle fuses up to 100 amperes. It measures 7 1/2 inches and weighs 2 ounces.

PRACTICAL  
IMAGINATION  
AT WORK FOR YOU

**PowerFlite**—incredibly smooth,  
delightful to drive, and a Chrysler Corporation exclusive

# America's Newest Automatic Transmission



## **PowerFlite**

- No other transmission can match its combined acceleration and smoothness.
- No other transmission can match its lightweight, rugged construction.

This great development—**PowerFlite**—is yours in Chrysler Corporation cars exclusively!

## **Double action: smoothness and performance**

All transmissions are smooth at certain stages. But **PowerFlite** is smooth at every stage. All the way from dead stop through cruising speeds. No other system can match **PowerFlite's** zip-charged breakaway. And none can match its performance in the highway cruising ranges!

We mentioned earlier that **PowerFlite** is rugged. Here's what we mean: during a road test, **PowerFlite** was jammed through 12,000 full-throttle starts. After 79,000 miles of severe testing—during which no servicing or repairs were required—the transmission was disassembled. Each part was examined minutely. But no appreciable wear could be found!

## **Pioneering background**

**PowerFlite** grew out of Chrysler Corporation's pioneering work with transmissions. Today, the superbly engineered Chrysler Corporation cars offer you the choice of a variety of transmissions to suit your personal preference: the famous Synchro-Silent, Overdrive, Hy-Drive, and the brilliant new **PowerFlite**.

You'll enjoy the lithe beauty, the luxurious appointments and comfort, and the scintillating performance of the great new Plymouth, Dodge, De Soto, Chrysler and Imperial cars. The dealer near you will be pleased to put the model you select at your disposal—today, if you wish!

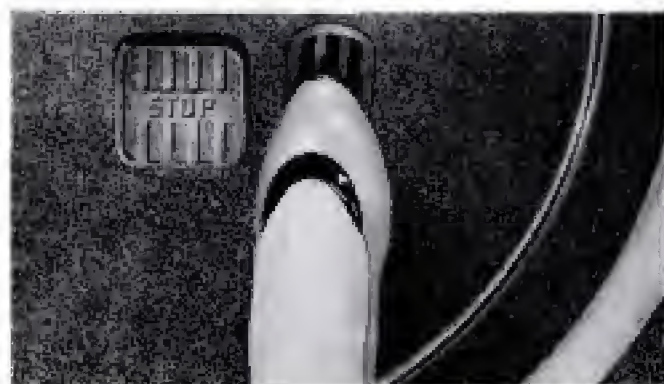

**TO START**—turn on ignition switch key, select drive, then touch the accelerator and you glide forward. At the right moment, **PowerFlite** puts itself into "high" so smoothly you'll not notice.



**TO STOP**—simply touch the brake. There is no declutching or gear changing. If you stop on an incline, **PowerFlite** helps to keep you from rolling backward.

**CHRYSLER CORPORATION** PLYMOUTH; DODGE; DE SOTO; CHRYSLER & IMPERIAL CARS

Dodge Trucks, Chrysler Marine & Industrial Engines, Oilite Metal Powder Products, Mopar Parts & Accessories, Airtemp Heating and Air Conditioning, and Cycleweld Cement Products

Enjoy Medallion Theatre—dramatic entertainment for the whole family on CBS-TV.

# Looking for Something?

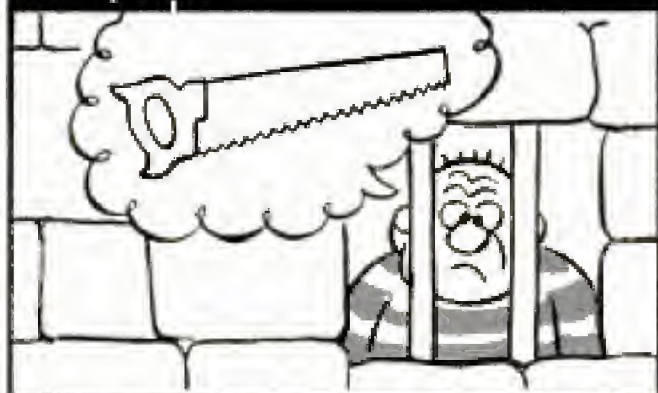

**FOR ALL HOME  
WORKSHOP EQUIPMENT  
LOOK IN THE  
'YELLOW PAGES'  
OF YOUR TELEPHONE DIRECTORY**

## Mr. Peepers Does His Homework

(Continued from page 114)

been so skillfully soldered you can't find the seams. He still turns out expertly wrought tie clasps, rings, cuff links and similar items for favored friends.

Wally admits that it took him years to become really proficient as a silversmith, but insists that anyone can learn. And, unlike many avocations, it needn't cost much to start.

"For soldering, you can buy a gas torch nozzle and rubber hose that attaches to a gas stove for five bucks," he points out. "Instead of fastening the air-pressure tube to an expensive compressed-air tank, you make a wooden mouthpiece that can be held by your teeth. Blow your own pressure. That leaves both hands free to work on the piece."

Tools he advises for a beginner include long diamond tweezers with teeth in the nib, a jeweler's saw and blade, and soap to lubricate it. "You need two grades of jeweler's files, half round with pointed ends, and a set of needle files for notching wire so it can be bent at right angles and come out square instead of curved on the corner," he says. Liquid flux, low-temperature wire silver solder, metal shears, round and needle-nosed pliers, a ring mandrel, a 1/8-horsepower motor with grinding and polishing wheel, a rouge stick and fine emery complete a basic kit.

"The whole thing," Wally estimates, "should come to about \$20, including enough sheet silver, square silver wire and 18-gauge round wire to turn out your first practice jobs."

A man should start by making chain, to practice soldering and filing each tiny link, until he can make a joint on every first try, and can handle a file like an artist whisks a paintbrush. "By that time," predicts Wally, "he'll have quite a chain. If he gets sick of making links, a finger ring is good practice and will give him something to show his wife."

If you haven't got a ring mandrel, the actor reveals, you still can make a ring. "Just take a strip of paper a quarter of an inch wide, wrap it tight around the knuckle you want it to fit over, mark it and add the width of the silver," he says. "That 'width of silver' takes care of the surface stretch and the inside surface crimp when you bend the band. It always comes out just right.

"Watch out for notch bend joints," he warns. "Press the surfaces together hard and the solder will run right in. Leave them open and it won't."

(Continued to page 274)

# Big News... for Bench Saw Owners

Now, you can joint, plane, and shape wood at home on your own bench saw!

**CRAFTSMAN**  
REG. U.S. PAT. OFF.

**Molding  
Cutter Head**

**\$4<sup>95</sup>**

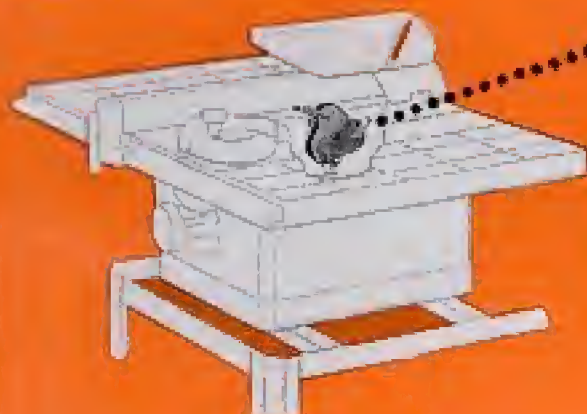

The CRAFTSMAN Cutter Head fits bench saws with 1/2, 3/8, or 5/8-in. round arbors, and most dado inserts. Included are wrench, space washer, bushings, and instruction manual showing how to plan designs. A full selection of seventeen cutter bits are available at Sears stores everywhere.

Be constructive; save dollars! Make your own moldings, corner joints, baseboards, and panel frames. Be creative; enjoy living! Cut table top edges, picture frames, and picture moldings. You'll do these and many more useful, fascinating jobs with a CRAFTSMAN Molding Cutter Head and Bits.

You don't need expensive, specialized power tools. You don't need costly, pre-shaped lumber. Just attach cutter head to your bench saw, flick the starter switch, and ease rough lumber into the whirling bits. It's as simple as pushing wood across a table — and actually, that's just how it's done! Your work is cut cleanly, accurately. A few strokes with sandpaper for perfection's sake and the piece is finished.

Every cutter bit does a special job. With several sets you can combine cuts, make literally thousands of designs . . . The number is limited only by your imagination!

Why not begin now — shaping, jointing, and planing — with a CRAFTSMAN Cutter Head. Price, \$4.95. Your Sears retail merchant will give you helpful pointers on bit selection. Visit him today!



1-inch planer and jointer for close tolerance work

**Cutter Bit Sets**

**\$2<sup>50</sup>**

3 bits per set



Bead cutter bits for furniture trim, cabinets, etc.



Decorative molding bits for picture frames, trim . . .



Cabinet door bits for decorative trim on cabinets, etc.



Base molding bits for building trim, shoe molding.

**CRAFTSMAN** Hand and Power Tools by **SEARS, ROEBUCK and CO.**  
Famous for fine quality . . . precision performance . . . low price!

# LONG QUART



**SAVES  
OIL  
and  
ENGINE  
WEAR**

This 100% Pennsylvania motor oil with THE *Tough-Film* stands up under intense heat, resists formation of oil-wasting engine deposits. Your engine stays clean, smooth-running, *uses less oil*. And because Pennzoil *lasts* so long, it guards against costly wear caused by acids and friction. Switch to Pennzoil now!

## As big a difference as ever!

Most motor oils now contain detergents. A detergent's job is not to lubricate, but to improve conditions under which oil lubricates. Pennzoil, too, contains detergents, but its basic lubricating quality, resulting from superbly refined Pennsylvania crude, still provides an extra margin of safety.

Sound  
your **Z**  
at this sign...



© 1964, The Pennzoil Co.  
Member Penn. Grade Crude Oil Assn., Permit No. 2

BETTER DEALERS IN EVERY STATE FEATURE  
PENNZOIL® MOTOR OILS & LUBRICANTS

Between Wally's work on the show, silversmithing, carving and constant experiments with new materials (one of the latest proved to him that plastic cement would mend rips and holes in his clothes much quicker and just as securely as needle and thread), all his evenings are taken up.

Week ends are reserved for house building in Rockland County. So far, the driveway is in, footings are dug and all that remains to be done is build the house. It's going to be of stone and mortar because, as Wally puts it in his practical way, "there are plenty of rocks in Rockland County." With all that natural material at hand, it would go against the Cox grain not to use it. Furthermore, masonry will take longer, and Wally is in no rush. The house is more than just a house—it's a plot to get away from bustling city crowds and to indulge his favorite pastimes—studying birds, bugs and plants. "I hunt wild flowers because there's nothing wild about hunting them," he says. "You just go out, sit in the woods and look around."

And, as he told one friend, "There's no one around to stop and ask me when Mr. Peepers is going to marry Miss Remington—or vice versa." ★ ★ ★

## Eye-Movement Glasses

An extra pair of eyes seems to sprout beneath the cheekbones of a person using a new visual aid. The effect comes from inclined transparent mirrors attached to a pair of glassless spectacles. With the tool an observer can watch a reader's eye movements and discover the reasons for retarded reading rate or comprehension. It is possible to estimate the length and number of eye pauses, the number of backward eye movements, and the smoothness of eye movement rhythm.





# Motorola CAR RADIO

## Lowest Price Ever

only \$39<sup>95</sup>



Powerful! Rich Superior Tone  
Razor-Sharp Selectivity



**PUSHBUTTON  
MODEL 554**

Here's a luxury car radio at a budget price! Five-station, push-to-lock pushbutton tuner. New larger speaker for new depth in tone. Low battery drain. \$54.95.

Drive to your authorized Motorola dealer and get this spectacular radio buy! The powerful, top-performing Model 404 radio at the low, low price of \$39.95! Rugged! Shock-resistant! Has five tubes plus rectifier and superheterodyne receiver. Automatic volume control reduces fading. Heavy-duty vibrator power supply for low battery drain. Hear it today—installed while you wait!

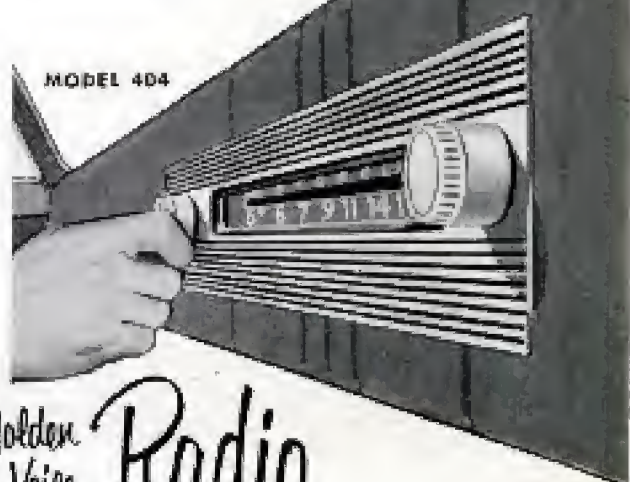

**MODEL 404**

Better See the Motorola TV Hour on ABC-TV Tuesday nights in most cities

Better See **Motorola** Golden Voice Radio

# NEW PRINCIPLE OBSOLETES ALL OTHER SHOCK ABSORBERS



## COLUMBUS Shocks

embody the only major improvements in design and construction since the airplane type was introduced.

COLUMBUS gives an improved ride never before possible with ordinary conventional shocks. Columbus gives greater car control because it compensates more fully for sudden road changes. This means a safer ride for you and your family.

**"SAFETY KNOWS NO SEASON"**

**Write for free booklet...**

explaining in detail the new principle of Columbus Shock Absorbers. Discover the facts about America's Safest Shock Absorber NOW.

**HECKETHORN MFG. & SUPPLY CO.**

Dep't PM • 242 West Main Street,  
Littleton, Colorado



**COLUMBUS**  
Luxury ride SHOCK ABSORBER



## Guided Missiles on Leash

(Continued from page 101)

build up in guided missiles at high speed.

Temperature problems are most acute in guided missiles of the rocket type, for these fly the fastest. Electronic circuits can go haywire when heated to several hundred degrees. Even precisely fitted mechanical parts no longer operate the way they should. If a missile is fired from a tropical location where the ground temperature is high, flight heat builds up even more. If fired from a polar location having a sub-zero ground temperature, the missile and all its parts are subjected to an extreme and quick change of temperature.

To study these problems, the Army has established a new climatic laboratory at its White Sands Proving Ground in New Mexico. Here a complete electronic circuit or a valve can be cooled to a temperature of 65 degrees below zero, then hit with a blast of air heated to several hundred degrees in a simulation of the conditions that could occur to rocket components when launched from a polar site.

The next step at White Sands will be to refrigerate an entire guided missile in a big mobile deep-freeze igloo, then immediately place the missile on a launcher and fire it. Eventually the climatic laboratory will build some enormous climatic chambers in which the biggest rockets can be frozen or heated, undergo atmospheric pressure changes and shaken in simulation of flight vibration all at the same time. By operating all of the missile's electronic circuits, servo mechanisms, pumps and hydraulic systems while it is being subjected to this treatment, any failures that are likely to occur in flight from these causes can be pin-pointed on the ground.

The proving ground has a separate laboratory devoted to shock and vibration tests. Here a missile is subjected to the shocks which it might receive while being transported part way around the world and here the damaging vibrations that can occur in flight are duplicated. Flight vibrations can be so severe as to destroy parts of a rocket structure. They can be so intense that electric circuits come apart. Vibrations at certain frequencies can stop the clockwork-timing devices sometimes used in a missile. At White Sands, the research people use an array of mechanical cam shakers, dynamic shaking tables and centrifuges for testing rocket components. The program includes the redesigning of faulty parts so that these components become vibrationproof.

The guided-missile field is so broad now

(Continued to page 276)



Aluminum window screens that last a lifetime are easy to make with Reynolds Do-It-Yourself Aluminum, cost little. Mail coupon for free instruction folder.



Stunning desk and lamp are beautiful examples of the versatility of Reynolds Do-It-Yourself Aluminum. Patterns #542 and #541.



Radiator cover made of Reynolds Do-It-Yourself Aluminum is handsome, efficient . . . costs surprisingly little. Save up to 75%. Pattern #544.



This sewing center will win any homemaker's heart. Yet it's a simple, inexpensive project. Pattern #543.



Reynolds Do-It-Yourself Aluminum is now on sale at hardware and lumber supply dealers in this handy self-service rack.

# REYNOLDS DO-IT-YOURSELF ALUMINUM

... steals the show in  
home improvement field!

Reynolds Do-It-Yourself Aluminum is so easy to use that even the most amateur home owners are becoming "professionals" overnight . . . and saving lots of money in the bargain. The secret? This new kind of aluminum is specially engineered for really astonishing workability. You can bend it, saw it, drill it, plane it, join it and shape it, using ordinary hand or power tools.

New Reynolds Do-It-Yourself Aluminum comes in plain and embossed sheets, tubes, bars, rods, angles, screen and storm sash sections, Reynolds Reynolon film, and handy, easy-to-use fasteners.

"Easi-Bild"® patterns of the projects pictured on this page can be obtained for a small cost by filling in the coupon below. Each pattern contains complete list of materials needed. Also at your dealers, free, are (1) instructions for making aluminum screens and storm sash, and (2) a "how-to" booklet containing general instructions and suggested projects. Or send coupon.

Reynolds Do-It-Yourself Aluminum won't harm ordinary tools. Its use is approved by leading tool manufacturers. Home owners are cautioned, however, to use *only* Reynolds Do-It-Yourself Aluminum, because other types may harm ordinary tools. Reynolds Do-It-Yourself Aluminum can be identified by the special Seal attached to every piece.

No special tools are needed to make and repair things with new Reynolds Do-It-Yourself Aluminum. Saw it, plane it, join it, shape it, drill it with ordinary hand or power tools.

©T.M. Reg. Easi-Bild Pattern Company

### SEND FOR "EASI-BILD" PATTERNS



Reynolds Metals Company  
2502 South Third Street,  
Louisville 1, Kentucky

Please send me the following full-size "Easi-Bild" Patterns. I enclose . . . in cash or money order.

- LAMP No. 541 . . . . . 35c
- DESK No. 542 . . . . . 50c
- SEWING CENTER No. 543 . . . . . 50c
- RADIATOR COVER No. 544 . . . . . 50c
- ALUMINUM SCREEN,  
STORM SASH instruction  
folder . . . . . FREE
- "HOW-TO" BOOKLET with  
instructions and projects . . . . . FREE

Name.....

Address.....

City.....Zone.....State.....

Offer limited to the Continental U. S.

if you can hammer a nail...



you can build a new wall with **Knotty Pine**

# PANEL SHEETROCK

T. M. Reg. U. S. Pat. Off.

**THE FIREPROOF GYPSUM WALLBOARD**

Simplest system ever! You just nail easy-to-handle 16" wide, ceiling-height panels right to the studs. *All at once* you have a new decorated wall of beautiful Knotty Pine PANEL SHEETROCK using matching colored nails. The joints are a decorative feature. Also available in plain panels you can decorate yourself, or in predecorated striated finish. Use it with modern USG Metal Trim. Ask your USG dealer, or write Dept. PM 2, Chicago 6, Ill.

**UNITED STATES GYPSUM**

*the greatest name in building*



that no longer is it the specialty of a few experts in power plants and air frames. People from numerous technical fields are now at work on rockets and uninhabited aircraft, and more of them are needed. At White Sands alone, there are jobs waiting for 1000 or more young engineers who hold college degrees. Salaries start at \$3410 and range as high as \$10,000 per year, and the employment policy is to push research people ahead as rapidly as their abilities permit. There's room for improvement in every part of a guided missile.

Groups in all parts of the world, for instance, are trying to design better rocket motors. No other power plant compares with a rocket for acceleration and top speed and yet the rocket motor is regarded as extremely inefficient. One suggestion, advanced by Dr. Saul Pollock, rocket-combustion physicist of Rotor-Craft Corporation, is to find a way of controlling the acoustic resonances that occur inside the motor chamber. Many rocket explosions and irregular firings can be traced to this cause, Doctor Pollock asserts, and he believes that the rocket motor will be converted from a fuel-hungry monster to one of our most efficient power plants if the power in its acoustic by-products can be controlled and put to work.

Today the United States is manufacturing a number of different kinds of guided missiles and is completing the designing and engineering of still other types. The age of push-button warfare is here. ★ ★ ★

## Expansion Plug Seals Open End of Tube

Open gas and liquid lines can be sealed temporarily with a rubber plug that fits into the open end of a tube. Installation or any repairs then proceed without installing a valve or pinching off the pipe. The synthetic-rubber plug and a cylindrical casing are mounted on a bolt tightened at one end by a wing nut. The tightening causes the rubber to bunch up and form a seal which will resist a pressure of 100 pounds. Several sizes are manufactured.



**MASTER GARDENER**

**NO PUSHING SELF-PROPELLED**  
It's a lawn mower  
It's a power sickle  
It's a rotary tiller  
It's a cultivator  
It's a plow  
It's a roller  
It's a sprayer  
It's a pump  
It's a blower  
It's a trimmer  
It's a brush cutter  
It's a stump puller  
It's a trencher  
It's a post hole digger  
It's a concrete vibrator  
It's a concrete pump  
It's a concrete vibrator  
It's a concrete pump  
It's a concrete vibrator  
It's a concrete pump

Tractor shown with Rotary Tiller Attachment

Prepares mat-  
tressed, deep mud beds without labor. Built-in power take-off to drive pumps, saws, generators, etc. Safety clutch—can't burn out. More versatile and efficient than tractors costing twice as much. Converts in minutes to Tiller, Power Sickle, etc. Basic self-propelled 2 hp tractor. Briggs or Stratton famous engine. **\$119.50**  
Rotary Tiller.....**\$42.50**  
Cultivator.....**\$35.75**  
Snow Blower.....**\$39.50**  
Disc Mower.....**\$15.75**  
Furrowing Tool.....**\$4.75**  
Plow.....**\$15.00**  
Rotary Lawn Mower.....**\$42.50**  
Sickle Bar Mower.....**\$42.50**  
Lawn Mower Hitch.....**\$4.50**  
Freight prepaid to most areas. Easy payment plan available.

**GET BEDROCK FACTORY PRICES!**

**BUILDER'S HAND SIGHTING LEVEL**

**PORTABLE LIGHT PLANTS**  
PUSH BUTTON START A.C. LIGHT PLANT 600-700 watts—115 v.—60 cyc. A.C. Powered by a rugged 2 hp. easy-starting Briggs gas engine. No wiring necessary. Just plug in and operate. Plenty of current for any air burner, freezer, toaster, emergency lights, etc. which require up to 7000 watts. Ideal for Civil Defense, Fire Jumps, drills and camps. Complete with Voltmeter and built-in winding to charge 6 v. auto batteries. Item 24. Wt. 75 lbs. As prepared for use or stored **\$143.50**  
1000-1200 Watt Plant (Item 25) same as Item 24 but larger generator & engine... **\$199.50**  
350 Watt Plant (Item 23) 115 v. 60 cyc. 1 1/2 hp. Briggs Engine. Perfect for lights, radios, small power loads. Wt. 65 lbs. Factory price... **\$99.75**

**GIANT 2000-2500 WATT PLANT**  
110-130 V. 60 cyc. A.C. Absolutely the best made—exclusive dynamically balanced armature! Heavy windings develop up to 2000 watt overhead for motor starting. Skid-mounted—portable. Powered by easy starting Briggs of 6 hp. Wisconsin engine—complete with all accessories; engine easily disconnected for other uses. Big control box, voltmeter, no wiring necessary. Ample current for all purposes. Factory warranty and complete instructions included. (Item 31) Wt. 310 lbs. Reg. price \$585.00. Special at **\$299.50**  
Generator Only and control box... **\$169.50**  
3000-3500 WATT PLANT (Item 32) 110-220 v. 60 cyc. A.C. Belt drive Wt. Engine. Push button start. Wt. 370 lbs. Heavy duty \$399.50 Generator only for belt drive. Wt. 110 lbs. (Item 33) **\$239.50**  
MASTER-LITE 2500 Watt Plant 110/220 v. 60 cyc. A.C. A powerful plant, ruggedly constructed and yet designed for easy portability. Can be started by rope or handle 1 1/2 v. electric push button starter. Built-in winding to charge battery. Powered by a big 5.19 HP Briggs engine, complete with all accessories. Includes control box, voltmeter, and handy plug-in power receptacle. An ideal plant for permanent or stand-by service. Wt. 225 lbs. Reg. price \$487.00. Factory Price—Item 21 **\$329.50**  
Generator Only and control box... **\$169.50**

**HI-LINE 6000 WATT PLANT**  
Push Button Start, 115-220 v. 60 cycle A.C. A brace of a power plant with a rugged 1 1/2 hp. Wisconsin engine. Plenty of electricity for WASHES, Water heaters, freezers, machinery, etc. Affords both 110 and 220 volts. Ideal where heavy current is needed. Wt. 300 lbs. Easily worth \$895.00. With self starter. Factory price... **\$645.00**  
Same plant but with Crank Start... **\$585.00**  
Generator only... **\$345.00**

**DIESEL LIGHT PLANT**  
(Item 160) Diesel Motor 11-12 hp. 115/220 v. AC. Single or 3 phase. 1800 rpm. Voltage adjustable. Freezes continuous low load, heavy duty service is important. Factory price... **\$1895.00**  
14-11 kw. GAS DRIVEN PLANT. 115-230 v. 60 cyc. AC. Single or 3 phase, powered by a 4 cylinder Wisconsin air cooled engine. Belt driven. Constructed similarly to Hi-Line 6 KW shown above but much larger. (Item 237) with crank start Wt. 900 lb. Factory price **\$1075.00**  
Same plant with elec. self-starter... **\$1145.00**  
We make fully automatic controls to operate any of the above light plants. Write for details.

**POWER MASTER ARC WELDER**  
(Item 280) Spot a portable, rugged, self-powered industrial type welder with terrific performance, yet at a price hundreds of dollars less than you'd expect. High capacity DC welding unit on casters goes to tackle any job with confidence—easily handles anything up to 2" plate using from 1/16" to 3/8" rods. Built-in stabilizer and dual control simplifies any welding job from 30 to 250 amps. Welder is powered by 1 1/2 HP cylinder air cooled Wisconsin industrial engine with cable V-belt drive. Mounted on a welded steel chassis—easily transported on trailer or pick-up truck. Ideal for shop, factory or farm welding. Complete with instructions and electrodes. Wt. 480 lbs. Compares with welder costing \$1200. (Item 280) **\$399.50**  
Special month only **\$359.50**

**MASTER AIR COMPRESSOR**  
COMPARE!—This is the only compressor built with a NO RUST stainless steel tank. Safe up to 300 lbs. (Item 200) High pressure 100 psi large volume of air for any heavy duty use. For painting, spraying, inflating truck & auto tires, tireless & the hundreds of other jobs done by compressed air. Piston type. 2" thru compressor with built-in air filter. Master built with built-in strength alloy and precision bearings. Tank, 12" x 24", 3100 psi. In. cap. Equipped with automatic safety shut-off and stops motor to maintain desired pressure (up to 150 psi) and check valves, safety valve, gauge, shut-off valve, 20 ft. air hose and tire chuck. Beautifully balanced on built-in rollers and rubber tires. Don't take chances with used or surplus equipment. Our compressors are factory new and are guaranteed SAFE. Low factory prices. With 2 1/2 HP., 150 v. AC motor. (Item 2175) **\$109.50**  
With 3 1/2 hp. motor. Reg. \$109.50. (Item 201A) **\$129.50**

**EXTENSION CORD**  
Item 101 Heavy duty, made of Buna rubber insulated with 14-2 conductor, stranded wire enclosed in a treated braided jacket. So tough that you can drive over it. Use indoors or out. Reels strictly up to 400 ft. without coilage drop. Complete with heavy rubber plug and outlet. (Item 101) 40 ft. (wt. 2 1/2 lbs.) Usually **\$4.50** Special... **\$1.99**  
Combinations 2—40 ft. & 1—20 ft. Total 100 ft. (Item 102) **\$4.95**  
100 ft. length 41 piece **\$4.95**  
Item 103 **\$4.95**  
REPTERNE CABLE—1 1/2 in. diam. 180 ft. Heavy duty, very flexible. 20 year quality. Wt. 5 lbs. 100 ft. Complete with rubber plug and outlet. A terrific buy at only **\$8.95**

**Variable Speed Selector**  
Heavy duty, made by E. F. GOOD, for industrial use. Provides instant speed changes for any drive. For machine tools, dryers, printing presses, production lines, hoists—any operation requiring variable speed. Ideal for bridges, etc. (Item 68) **\$14.95**  
Variable free" planetary system. No hydraulic power losses or slippage. Infinite range, smooth operation, easy installation (data included). 3 sizes: 1/2-1 hp., wt. 30 lbs.; 1-2 hp., wt. 35 lbs.; 2-3 hp., wt. 40 lbs. Reg. \$18.95, \$22.50 and \$32.50. Our prices... **\$79.50, \$89.50 and \$114.50.**

**44 Pc. SOCKET SET**  
Highest quality, guaranteed non-breakable sockets made by Husky. Outstanding matched chrome alloy. Absolutely the best. Complete range of 21 sockets from 1/8" thru 7/16" (1/2" driver) & 2 1/2" thru 5 1/2" (1 1/2" driver). 200 extensions, reversible 1 1/2" ratchet, 3 drift pointers, sliding "7" head, all angle coupling, 1 1/2" spreader, 1 1/2" breakover, 3 pc. high chrome alloy combination wrench set & 8 pc. offset wrench set in a big dog-house toolbox with ample room for other tools (Item 200). We challenge anyone to match this set. Easily worth **\$49.50**. Wt. 16 lbs... **\$21.95**

**82 Pc. SOCKET SET**  
(Item 201) Contains a complete set of 28 sockets in 1 1/2" drive, 3 1/2" drive and 1 1/2" drive, plus all necessary extensions, handles, spreaders, reversible ratchets, etc.; all unusual, guaranteed against breakage. Beautiful matched chrome this wall alloy sockets in a big, dog-house steel box. Wt. 17 lbs. List price \$62.90. **\$27.95** Factory Special...

**BIG 1/2" DRILL VALUE!**

Now, a big production drill at an unheard of price. Heavy duty 3/4" drill with genuine Jacobs key chuck. Powerful smooth—drills thru 1/2" steel with ease. 115v. AC-DC. Written 1 year guarantee. Includes a complete set of 25 tungsten vanadium speed drills from 1/16" to 3/4" by 1/4" in a permanent steel metal box. 180 above ordinarily sell for \$115.00. Best value—scratched over. Reg. \$125.00. Factory... (Item 250) Special... **\$44.95** Wt. 15 lbs.

**JET FLOW BLOWER**

Terrible power air movement (1200 CFM) and quiet operation make this double inlet jet turbine blower unobtainable for heat-treating, cooling, drying, and air conditioning. Ideal for attic or barn ventilation, expanding spray booth exhausts, etc. 400 cfm. with any 1/2, 1/2 or 1/2 HP motor. 115v. and 220v. available. Variable speed motor pulley and belt. Dimensions 19" h. x 8 x 10 1/2". Outlet opening 12"x13 1/2". Wt. 35 lbs. (Item 245). Reg. \$54.50. Special... **\$27.50**

**HEAVY DUTY D-C ARC WELDER**

Use as portable or shop welder. Up to 300 amps. Better model. Made of 100% die-cast, continuous service. Wt. 110 lbs. (Item 285) **\$99.75**  
Dual control model same as above but with built-in dual rheostat for low heat softening, brazing, welding. Special... **\$119.50**  
WELDING KIT Two 1/2 in. leads, welding helmet, electrode holder, ground clamp. Sold only with welder. **\$16.50**

Send check or M.O. Prices f.o.b. Factory. 10 day Money back guarantee. SEND 10c for... **BIG 1954 Catalog**  
**MASTER MECHANIC MFG. CO., DEPT. 33C Burlington, Wis.**

Gardeners  
you know:



### Homer Wurple

Homer is the creative type. He likes to garden, and loves to make up his own plant foods. Is always dreaming up exotic combinations like powdered elk horns, aspirin, dehydrated whale's milk and dried blood from the Chichi-Chichi bird. Hasn't hit a good formula yet. Is beginning to notice that his neighbors who use Vigoro have really beautiful gardens.

There's a bit of Homer in all of us. Gardening just wouldn't be gardening if you couldn't get excited about new things.

But in gardening, too, it's nice to have "old reliables" to fall back on. Tried and true varieties of roses, for example. Also Vigoro—complete, balanced plant food.

Vigoro just had to be good to get where it is. And each year, we make it better than the year before. That's why amateur and expert gardeners have made Vigoro the most-used plant food in the world. What better proof of quality could you ask for?

There are now two kinds: Regular Vigoro . . . and new Instant Vigoro that's soluble in water. Both can make any plant grow and thrive even in plain sand.



Regular VIGORO

Instant VIGORO

\*Vigoro is the trademark for Swift & Company's complete, balanced plant food.

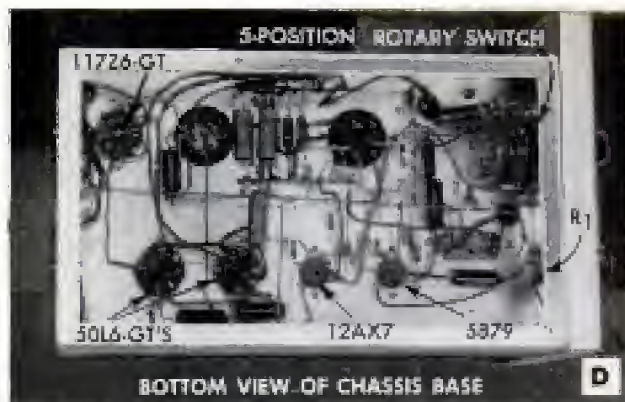

### Super-Fidelity Home Phono - Has Back-Loaded Cabinet

(Continued from page 248)

50L6's; the driver stage is a directly-connected dual triode 12AX7. The input tube is a relatively new low-noise, low-microphonic pentode 5879. It is available from radio-parts houses for about \$1.75; the rectifier tube is a 117Z6-GT.

The phonograph unit has a 3-speed changer with turn-over crystal pickup for microgroove 33 and 45 r.p.m.; and standard 78 r.p.m. This V-M model 920 record player has a "siesta" switch, Fig. 3, so that both motor and amplifier can be turned off automatically at the end of a series of records. The usual way of operating is indicated in Fig. 2 where the off-on switch is on the amplifier panel.

Any crystal phono pickup which has 1/2-volt or more output is suitable for this amplifier. However, reluctance pickups such as G.E., Pickering etc., are not

(Continued to page 282)

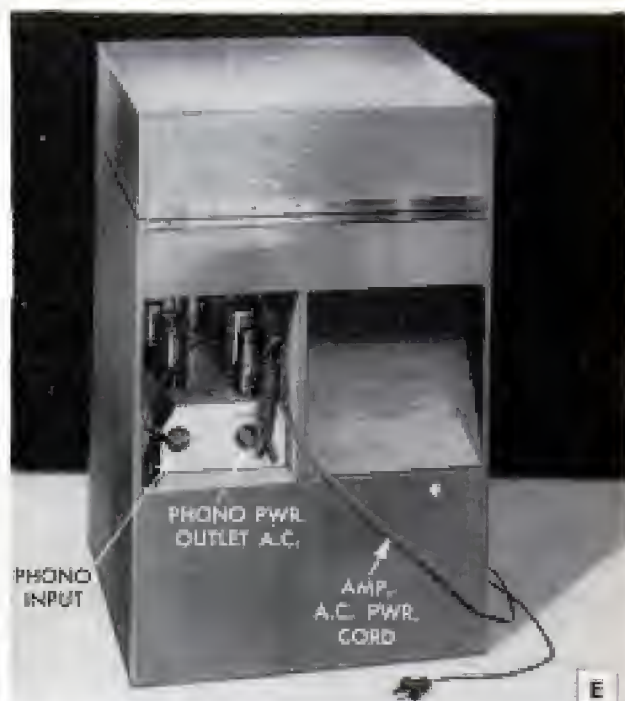



ALL IT NEEDS  
IS  
YOU!



• Swing into the saddle of this beauty. Twist the throttle to exciting adventure on highways and byways. Thrill to the surging power as you ride in luxurious comfort through mile after mile of tireless travel. Truly, the Harley-Davidson "Golden Anniversary" 74 OHV is the one motorcycle every rider wants to own. See it! Thrill to a test ride at your dealer's today. Ask about his easy-payment plan. For your copy of the action-packed ENTHUSIAST Magazine and illustrated literature, send 10¢ to Harley-Davidson Motor Company, Department P, Milwaukee 1, Wis.



**HARLEY-DAVIDSON**  
**HYDRA-GLIDE®**

**FREE**

**GET THE WORLD'S LEADING  
TV & RADIO CATALOG**

# ALLIED'S 1954 ELECTRONICS BUYING GUIDE

268  
VALUE-  
PACKED  
PAGES



SAVE ON  
EVERYTHING  
IN TV AND  
RADIO

**Everything for Experimenters, Builders,  
Amateurs, Servicemen, Engineers  
and Soundmen . . .**

Get ALLIED's big 268-page Catalog featuring the world's largest selections of latest top-quality electronic equipment at lowest, money-saving prices. See the newest in custom TV chassis, TV accessories, FM and AM radios, High-Fidelity sound, Amateur equipment, P.A. systems, recorders, test instruments, builders' kits, industrial electronic supplies—plus thousands of parts, tubes, tools and books. Get more for your money—send today for your **FREE 1954 ALLIED Catalog!**



NEW HOME OF ALLIED RADIO  
*ultra-modern facilities TO SERVE YOU BEST*

**ALLIED RADIO**

**SEND FOR  
FREE  
CATALOG**

ALLIED RADIO CORP., Dept. 5-88-4  
100 N. Western Ave., Chicago 80, Illinois  
 Rush **FREE** 1954 ALLIED 268-Page Catalog

Name \_\_\_\_\_

Address \_\_\_\_\_

City \_\_\_\_\_ Zone \_\_\_\_\_ State \_\_\_\_\_

recommended for use in this back-loaded cabinet. The amplifier gain must be so high, and efficiency of a back loaded speaker is so great, that it is impractical to use them.

There are two parallel heater circuits in the amplifier. The 117Z6-GT is one all by itself, the other includes audio tubes.

Note R-27 resistor across 12AX7 and 5879 heaters; this makes for quieter operation, by running the heaters slightly below rated voltage. Should one of these tubes fail, there will be added voltage applied across R-27. This is a 5-watt wire-wound resistor and it will take this extra load until the defective front-end tube is replaced.

Photos B, D and F show various views of the completed amplifier chassis. When mounting the component parts, be sure that

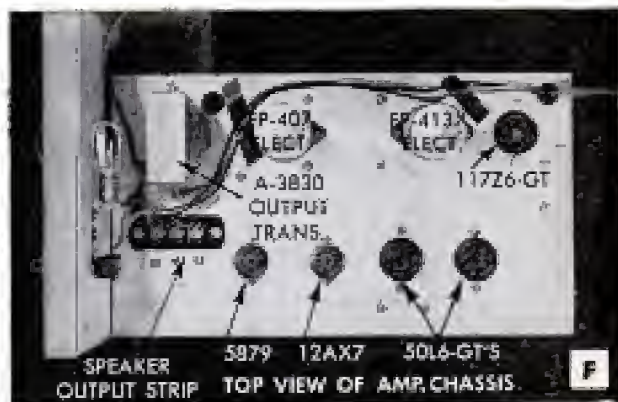

nothing is "grounded" to the metal chassis. Each 4-section electrolytic-capacitor unit has its Bakelite wafer mount screwed to the top of the chassis. Use small-head mounting screws so that the can does not touch the chassis by way of the screwheads.

The amplifier chassis base is detailed in Fig. 4. The phono-input jack is mounted on the small Bakelite panel so that both terminals are insulated. The short lead from this jack connects to the common bus bar, see Fig. 1, the insulated common bus is indicated by the heavy line in both circuit diagrams. As far as possible, keep grid and plate leads apart, or cross them at right angles. Push them, after soldering, close to the chassis; any grid wire close to the chassis is automatically shielded. Scotch tape is handy for this purpose. Solid push-back No. 20 tinned copper wire is used for wiring; the common bus bar, however, is bare No. 14 tinned copper.

The .05 mfd. 400-V. capacitor C16 is important, one terminal connects to the metal chassis by means of a soldering lug under a short machine screw and hex nut; the other terminal connects to the common bus. Feedback must be connected correctly. The leads to each push-pull 50L6-GT are color coded in the diagrams. ★ ★ ★

(To be continued next month)



first,  
compare  
**PRICE TAGS**  
... then ...

**COMPARE  
VALUE!**

**Pagemaster  
HOMES**

**GIVE YOU FAR MORE  
PER BUILDING DOLLAR** because of

- ✓ PROFESSIONAL PLANNING
- ✓ QUALITY MATERIALS
- ✓ TREMENDOUS LABOR SAVINGS



**THE ALDRIDGE**—1300 sq. ft. including garage—2 bedrooms—features economical floor plan, large rooms, low modern exterior. Designed for construction on a slab.

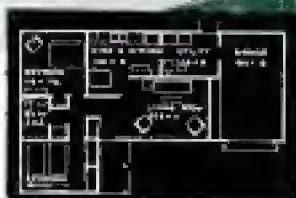

**\$3,700<sup>00</sup>**

All prices shown are freight paid within 11 Midwestern States—slightly higher in other areas.

IF YOU CAN DRIVE A NAIL . . . IF YOU CAN FOLLOW INSTRUCTIONS—THEN YOU CAN BUILD YOUR HOME THE PAGEMASTER WAY AND PUT AN EXTRA

**\$3000<sup>00</sup> IN THE BANK!**

Probably the biggest, most important purchase you'll ever make is your home. Don't buy the price tag until you compare values!

Pagemaster offers you many, many advantages and far more for your building dollar. Take advantage of our 50 years of building know-how, professional planning and modern engineering techniques that go into every Pagemaster home.

Only top quality materials and the best nationally advertised equipment are used. That is why Pagemaster homes set the quality standards for the entire home industry.

Our large quantity purchases result in great material savings. These savings are passed on to you. Besides, all materials are measured, cut and sub-assembled right at the factory, eliminating the possibility of costly, on-the-job errors. Whether you do it yourself or hire someone to help you, you'll build in less time, use less labor, with less waste and for far less money.

Build today the Pagemaster way and save, save, save! Enjoy the styling, the comforts, the quality that only Pagemaster can give you, and at a price you'll be glad to pay. Write for names and addresses of satisfied Pagemaster home owners everywhere. There may be one or more in your neighborhood. Buy Pagemaster and put the additional dollars in the bank!

PAGEMASTER HOMES come to you in one package ready to erect. Any plan can be modified to meet individual requirements. And this is important too—Pagemaster Homes are built to meet FHA and VA financing requirements.

WHETHER OR NOT YOU ARE PLANNING TO BUILD THIS YEAR, YOU'LL WANT THIS CATALOG! SEND 25c TODAY FOR THIS BEAUTIFUL, FULL-COLOR HOME BOOK.

**Pagemaster**  
300 PIERCE ST.  
SHAKOPEE, MINNESOTA  
"PANELIZED FOR EASY ERECTION"



**"Best Sellers" BY PAGEMASTER**



**\$3,490.00**



**THE FREMONT**—24'x32'—2-bedroom beauty—lots of living at minimum cost.



**\$4,736.00**



**THE DEAN**—1194 sq. ft.—including garage, 3 bedrooms, compact kitchen, large closets.



**\$5,224.00**



**THE KAYE**—1146 sq. ft.—4 large bedrooms, U-shaped kitchen, sheltered entrance, hip roof—Deluxe throughout.

CLIP AND MAIL

**PAGEMASTER HOMES  
SHAKOPEE, MINNESOTA**

Gentlemen: Send your full-color catalog of beautiful Pagemaster Homes. 25c in coin is enclosed.

NAME \_\_\_\_\_

ADDRESS \_\_\_\_\_

CITY \_\_\_\_\_ STATE \_\_\_\_\_

# THE TWELVE FINEST *American Classics*

(Continued from page 153)

limited production. That is what makes them the exciting cars they are. They were scarce when built, they are rare today. Because of their special construction, they have "hand-tailored craftsmanship," they are works "of mechanical perfection" and they "make the blood race a little faster in any person who appreciates machinery."

"A Classic is a man's car." The Kissel White Eagle Speedster, built in 1927, is exactly that, without ornamentation, power conveniences and other "complex simplifications." The man who owned and drove a Kissel was a man through and through, say the followers of the Classics. And the same is true of the Stutz Super Bearcat of 1932.

"It is a car designed more for impression and appearance than for practical usage." . . . "It is an engineering exaggeration, magnificently overdone. It is not practical, but it is more car than was ever put on four wheels before or since."

Nobody is suggesting that Detroit should abandon its present designs and go back

to the Classic standards. In the first place, the price would be prohibitive. The Duesenbergs cost about \$8500 back in 1931 and that was without the body! When you bought one, you bought the chassis (engine, frame, running gear) and hired someone to put a body on it. That is the reason for hyphenated names like Roadster-Murphy, Victoria-Rollston—Murphy and Rollston being noted body builders of the time.

In a sense, however, Detroit does make use of classic designs because such designs are part of the history, the experience, of automobile design and no engineer or stylist can ignore history. The Classic was ahead of its time—it led the way. Look again at the 1933 Pierce Silver Arrow V12. Built 21 years ago, it still looks modern, even to the recessed door handles that are yet to come out of Detroit.

Probably the best definition, although certainly not the most definitive, was this one: "A luxury car of yesterday that people of today look at and say, 'Gee! What an automobile! I would sure like to own one like that.'"

In a word, then, a Classic is a car with "character"—a car that "excites the imagination." It is, as one poetic member wrote, "a hunk of iron with a soul." And, according to the Classic Car Club's motto, "They don't build them like that any more." ★ ★ ★

## IT SMELLS GRAND



SMIFF IT! YOU'LL SAY "THAT'S FOR ME!"

## IT PACKS RIGHT



CUT TO PACK IDEALLY!

## IT SMOKES SWEET

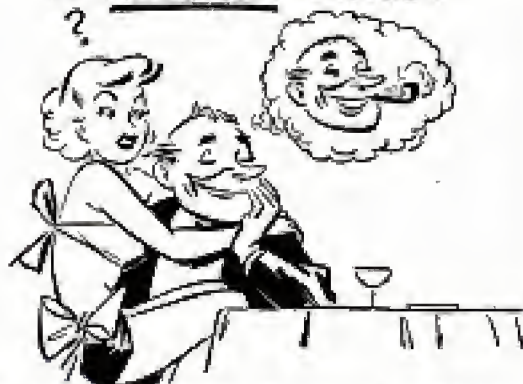

JOY YOU'VE DREAMED OF — YOU'LL AGREE!

## IT CAN'T BITE!

SIR WALTER RALEIGH'S BLEND OF CHOICE KENTUCKY BURLEYS IS EXTRA-AGED TO GUARD AGAINST TONGUE BITE. AND SIR WALTER RALEIGH NEVER LEAVES A SOGGY HEEL IN YOUR PIPE. STAYS LIT TO THE LAST PUFF.



*It costs  
no more  
to smoke  
The Best!*

**RELIEVES  
HEADACHE  
NEURALGIA  
NEURITIS PAIN**

**FAST**



**Here's Why...**

Anacin® is like a doctor's prescription. That is, Anacin contains not one but a combination of medically proved active ingredients. Anacin is specially compounded to give **FAST, LONG LASTING** relief. Don't wait. Buy Anacin today.



**G E A R S**

**In Stock - Immediate Delivery**  
Gears, speed reducers, sprockets, thrust bearings, flexible couplings, pulleys, etc. A complete line is carried in our Chicago stock. Can also quote on special gears of any kind. Send in your blueprints and inquiries.

Send for Complete Catalog No. 10  
**CHICAGO GEAR WORKS**  
440-50 N. Oakley Blvd., CHICAGO 12, ILL.

**MACMILLAN RING FREE Xtra Heavy Duty**  
is the **ONLY** motor oil to **GUARANTEE:**

- to prevent Valves and Hydraulic Lifters from sticking
- to reduce Engine Ping... **or Your Money Back!**

For further information write: R. S. MACMILLAN, PRES.  
530 West 6th St., Los Angeles, Calif.

Say You Saw It in Popular Mechanics

**POWERFUL!**

Man, here's  
light! 1/4-mile beam —  
15,000 beam candle  
power. Compact, easy to  
carry, built to last! Uses two 6-volt  
batteries. See your dealer. **\$6.50**



**Delta POWER-KING** ELECTRIC LANTERN

**WHAT  
DO YOU WANT?**

**A GOOD BUSINESS  
OF YOUR OWN?**

**A HIGH PAY  
SPARE-TIME  
JOB?**

*Then* **FOLLOW THIS  
PROVED SUCCESS PLAN!**

Here is your chance to be your own boss, secure financial independence, build a future for yourself and your family in a profitable business in your own garage or basement. J. S. of Michigan writes, "I figure my profits (last season) at over \$1,000.00." Mr. C. H. R. of Ohio says, "This season I have taken in \$3,688.20." J. P. of Pennsylvania writes "I spent only 40c for a newspaper ad and have done nearly \$500.00 worth of business." Another owner writes, "I have had 4 mowers a day brought to me since last May . . . and do the grinding evenings at an average of \$2.50 each." Think of it! That's \$10.00 an evening in spare time. If you want to get ahead, make big money, be your own boss. Act Now. Write today for full details of our proved success plan.



**ONLY ON THE UNIVERSAL LAWN MOWER GRINDER**

can the inside face and edge of the stationary blade, and all reel blades, be ground to proper clearance

**ALL IN ONE SET-UP**

**WITHOUT REMOVING ANY BLADE FROM THE MOWER** . . . that's why this business is simple, easy, and interesting. No experience or long hours of study are necessary. A leading National Magazine says, even an inexperienced worker can do a good job. We furnish complete instructions, everything you need to get started . . . But you must take the first step. Just fill in and mail the coupon below. Do it right now.  
**ROGERS MFG. CO., DEPT. M-24, LINDSEY, OHIO**

**SEND THIS COUPON NOW**

ROGERS MFG. CO., Dept. M-24, Lindsey, Ohio  
Please send me full details about the profit possibilities of Lawn Mower Sharpening.

NAME \_\_\_\_\_

ADDRESS \_\_\_\_\_

CITY \_\_\_\_\_ STATE \_\_\_\_\_

PROFESSIONAL-TYPE ELECTRIC  
**HAIR CLIPPER**



Removes  
Unwanted Hair

**Cadet**  
ELECTRIC HAIR CLIPPER

Saves time and money for the whole family! Has cool-running magnetic motor; fine-tooth blade for close cutting; streamlined plastic case, 110v 60 cycle AC; fully tested by UL. If your barber, beauty shop or dealer cannot supply you, order direct on 10-day money-back guarantee.

**ELECTRO TOOL CORPORATION**  
DEPT. C524-B • RACINE, WISCONSIN

**The Great Road Races of the World**

(Continued from page 183)

**Q:** John, you were the first American to win a Coupe des Alpes in an Alpine Rally. Will you tell us about that race?

**FITCH:** Of course, it isn't really a race. It is a rally—you are racing against time only. More than one person can win a cup in each rally—all you have to do is go through the whole event without losing any marks. You lose marks by failing to show up on time at any of the control points. It runs for about 2000 miles, through the Alps and in France, Switzerland, Italy and Germany.

**Q:** You are competing with the clock and the rules, is that it?

**FITCH:** Yes and there are special tests, like timed climbs up mountains from various controls, scattered all along the course. You have to be at these controls at exact times. In some sections, that requires very fast driving. In others, like in the city of Milan or in Switzerland, where they aren't quite so enthusiastic about cars racing around on their roads, you have a relatively low speed to maintain. It is almost always through the Alps, up and down the passes. Some roads are about six feet wide and of loose gravel on narrow, obscure passes open only a few weeks each summer. They are snowed in the rest of the year.

**Q:** What car did you drive in the rally?

**FITCH:** The Sunbeam Alpine—a two seater.

**Q:** What is the best sports-car race in this country?

**FITCH:** The sports-car racing fraternity has lost several established road courses, but through the Strategic Air Command of the Air Force has gained many more airport courses. Of the old courses, I liked the 6.8-mile country road at Elkhart Lake that permitted very high speeds on a somewhat rough road that swept over rolling country and through the main streets and sharp turns of that resort town. The airport race I enjoyed most because of the course was the McDill Field race at Tampa, Florida. There were several right and left high speed bends that required precise control and an interesting series of slow turns, some of which decreased in radius, requiring much attention in positioning.

**Q:** Are these airport races as challenging as the road race?

**FITCH:** With careful planning of the course they can be very interesting. Last winter's Tampa race was very fascinating—and safe, too. There were right and left-angle turns and switchbacks, fast and slow bends.

(Continued to page 288)

Something **NEW** under  
the **SON!**

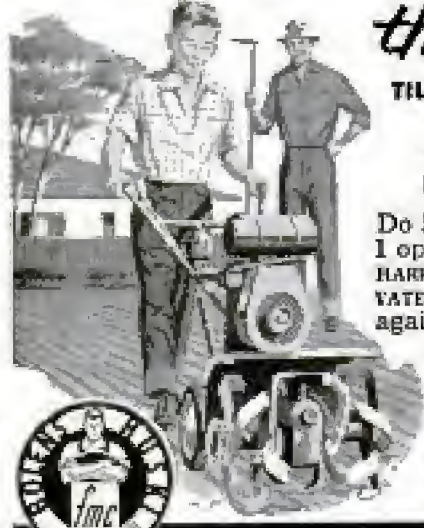

**TILL WITHOUT TOIL  
WITH BOLENS  
M-E MUSTANG  
ROTARY TILLER**

Do 5 gardening jobs in 1 operation: PLOW • DISC HARROW • AERATE • CULTIVATE. Tines Guaranteed against Breakage.

Bolens offers a complete line of Rotary Tillers in 3 hp, 4½ hp and 6 hp. AVAILABLE WITH WORK SAVING PLUG-IN ATTACHMENTS.

**MAIL COUPON TODAY!**

**BOLENS PRODUCTS DIVISION**

Food Machinery and Chemical Corporation  
265-2 South Park Street, Port Washington, Wisconsin

If you are interested in:

<input type="checkbox"/> TILLERS	<input type="checkbox"/> MOWERS
<input type="checkbox"/> TRACTORS	<input type="checkbox"/> CHAIN SAWS

Name \_\_\_\_\_  
Address \_\_\_\_\_  
City \_\_\_\_\_ Zone \_\_\_\_\_ State \_\_\_\_\_

# Once in a Lifetime

by Tom Hanlon  
CBS ACE RACE  
REPORTER

## GRANDFATHER WINS PANAMERICAN ROAD RACE!



**FIRST PLACE WINNER: C. D. EVANS, 58-YEAR-OLD GRANDFATHER, SHOWED THE YOUNGSTERS HIS DUST FOR 2000 MILES TO BRING HIS CHEVY HOME FIRST IN THE SPECIAL STANDARD DIVISION. C. D. SAYS: "I'VE NEVER SEEN A BATTERY TAKE A BEATING AND BOUNCE BACK FOR MORE LIKE THE LIFE-TIME."**

**SECOND PLACE WINNER: NORMAN PATTERSON (IN HIS SENSATIONAL FORD 6) SAYS: "AFTER THE WAY MY LIFE-TIME BATTERY STOOD UP, I'D NEVER HAVE ANY OTHER BATTERY IN MY CAR!"**



### BATTERY LIFTS 4,000-LB CAR!

IN A DRAMATIC TV DEMONSTRATION A LIFE-TIME BATTERY PUT OUT 37,720 FOOT-POUNDS OF ENERGY TO LIFT THIS CAR.



### THE COLD SEAT

FIRST RUN DOWN COMPLETELY AND PLUNGED INTO TANK OF WATER, A LIFE-TIME BATTERY WAS FROZEN SOLID FOR 3 WEEKS, THEN STARTED HEAVY LINCOLN MOTOR AT ONCE! LIFE-TIME IS ENGINEERED TO DELIVER FULL POWER FROM 40° BELOW TO 135°

### TELL IT TO THE MARINES!

THE **ONLY**  
BATTERY IN  
THE WORLD  
with a  
**6-YEAR**  
GUARANTEE

© 1953

EVERY DAY, 500 REQUESTS ARE MADE FOR LIFE-TIME BATTERY DEALERSHIPS... MORE THAN DOUBLE THE NUMBER OF VOLUNTEERS FOR THE U.S. MARINES!

IF YOUR DEALER DOESN'T HAVE THE LIFE-TIME BATTERY YET, WRITE FOR NAME OF DEALER NEAR YOU. IF YOU'D LIKE TO BE A DEALER OR DISTRIBUTOR, WRITE OR WIRE:



### LIFE-TIME WHIPS GERMAN "SUPER" BATTERY IN TEST

AFTER BEATING TOP AMERICAN BATTERIES BY A BIG MARGIN IN TESTS BY MOTOR TREND MAGAZINE, THE LIFE-TIME WAS MATCHED AGAINST FAMOUS GERMAN BATTERY IN "TORTURE TEST" WON BY 24% TO TAKE INTERNATIONAL HONORS.

CONTINENTAL MANUFACTURING CORPORATION Dept. PM-2 Washington Blvd. & Motor Ave., Culver City, Calif.

**The easy way to paint!**



*Speedy Sprayer*



Favorite of home owners and craftsmen for 20 years! SPEEDY SPRAYER gives your work that professional paint finish everyone admires. Sprays paint, enamel, varnish, lacquer, etc. . . . 4 to 7 times faster than hand brushing! Lightweight, portable, uses any 1/4 H.P. motor. Improved diaphragm principle assures clean, oil-free air. You'll find dozens of time and money saving uses for SPEEDY SPRAYER, including spraying insecticides 2-4-D and DDT. Complete outfit, without motor, only \$36.50.

At leading hardware, lumber, and auto supply dealers. FREE—write for handy booklet "How to Spray."

**W. R. BROWN CORPORATION**  
2635 N. Normandy • Chicago 35, Ill.

ONLY \$36.50 LESS MOTOR

**46 Surplus Twist DRILLS \$2**



**LESS THAN 4 1/2c EACH**

For hand or electric drills. Brand new, genuine hi-grade, hardened carbon tool steel drills. Sell for up to \$6 in the stores. You get about 5 each of the most frequently used sizes from 1/16" through 1/2". Tempered cutting edges easily bite through steel, aluminum, iron, wood, or plastic. Each drill hardened and designed to give 1800 drillings.

**\$2** complete set postpaid.

**5 pc. RATCHET BRACE AND AUGER BIT SET**

A well constructed ratchet bit brace, designed for heavy duty. Extra heavy chucks will hold bits to 1". Sturdy ratchet and easy turning knobs assure smooth, positive performance. 10" sweep 7/16" stock, highly nickel plated. Alligator spring jaws, hardwood grips. Auger Bits drop forged from high quality tool steel, solid centers, carefully sharpened double cutters, fully polished. Set contains one each of 4/16", 5/16", 8/16", 10/16", and 12/16" bits.



**\$4.98** complete set postpaid.

**MONEY BACK IF YOU DON'T AGREE THESE ARE THE BEST TOOL VALUES EVER!!**  
SEND CHECK, CASH, OR MONEY ORDER—WE PAY POSTAGE  
IF C.O.D. POSTAGE IS EXTRA.

**SCOTT-MITCHELL HOUSE, INC.**  
Dept. OX-15, 611 Broadway, New York 12, N. Y.

**WALTERS:** Road courses do present more of a challenge and that's why drivers usually like them better, but airport courses can be made exciting and challenging, if laid out skillfully.

**Q:** What does a sports-car driver have to be able to do adroitly in competition?

**FITCH:** Well, the tricks are pretty simple. Actually they are not important because everybody does them! Principally, you have to step on the brake and the accelerator at the same time so you can synchronize the engine speed and gear speed while braking. More important is knowing when to do the various tricks.

**Q:** Then the mental is more important than the physical?

**WALTERS:** It is coordinated—both mental and physical. Anybody can move a wheel just so, but it is the coordination that counts—knowing when to do what.

**Q:** Does that come only from practice?

**FITCH:** I think it is something you either have or don't have. You see drivers who have had no experience drive extremely well in their first race.

**WALTERS:** Yes, these drivers may have had no racing experience, but they have been the constant headache of the local constables for years, I'll bet!

**Q:** How do you tell a good driver?

**FITCH:** Just look at his times—they tell you a great deal. See how fast he gets around the circuit. At Le Mans, the best way is to drive behind him for a lap or so. You can see how fast he goes through the corner; what he is doing to correct the car's behavior, whatever it may be. Cars have different characteristics. If a car is not tracking straight through a corner, if the back end is set out from the front and the driver is correcting all the way through, you can be sure he is going at just about the limit of the car and that means he is good.

**Q:** Does a good driver drive the car at its limit all the time?

**WALTERS:** A good driver drives as slow as he can and still win.

**Q:** He doesn't know what that speed is at the beginning of the race, does he?

**WALTERS:** A good driver knows it before a poor driver.

**Q:** Tell us what a good driver does when he comes up to a curve.

**FITCH:** Here is a simple example of what happens at Le Mans. You come down the straightaway at your predetermined top speed. When you get to the 800-meter marker, cut off and get on the brakes.

**WALTERS:** In many cases the cutoff point and the way you slow down is not even the choice of the driver—it is prescribed by the team manager. As is the

(Continued to page 290)

# Try This Shaving Magic

## AERO SHAVE "Push-Button" LATHER



JUST PUSH VALVE  
...OUT COMES  
LATHER!



### Best Shave News In 50 Years!

- Richer, Creamier Lather
- No Brush Needed
- No Greasy Cream
- 3 Beard Softeners
- Contains Lanolin

**AERO SHAVE** Lather Bomb

## "HOW TO BUILD A FIBERGLASS CAR BODY"

This New Book contains up to the minute information on styling, mold-making, construction and materials. Only **\$2.00** postpaid. Complete Stock of Fiberglass Materials and Marco Resin for Cars and Boats

**ALLIED PRODUCTS ENGINEERING CORP.**  
1225 E. GRAND AVE. DEPT. A-2 EL SEGUNDO, CALIF

## HASTINGS

STEEL-VENT PISTON RINGS  
The best money  
you can spend on your car!

Make Money  
Selling  
Eshelman  
Power  
Mowers  
Riding  
Tractors &  
Rotary  
Tillers



**ESHELMAN** FOR Better LAWNS  
And GARDENS

Women Can Operate It.  
Free Catalog. Write  
**ESHELMAN Dept. R-52**  
119 Light St.,  
Baltimore, Md.  
333 N. Michigan Ave.,  
Chicago - 1, Ill.  
7470 Hollywood Blvd.,  
Los Angeles 28, Cal.

## CONVERT HAND MOWERS to POWER MOWERS

Takes less than 3 hours

The Handy-Dandy Lawn Mower Kit fits any hand mower from the 16 to the 20 inch size. Complete with all necessary parts. Kits can be purchased separately, complete with engines or complete with Pennsylvania mower.



Also manufacturers of complete power mowers (both reel and rotary) and garden cultivator with snap on attachments. Takes less than a minute to change.

**LE CLAIRE MFG. CO., Le Claire, Iowa, Dept. PM**

## How to make RABBIT CUTS with the new Stanley Handicrafter



The rabbit cut is a groove made on the edge of the work, either with or across the grain. One of the most useful basic cuts, it can be used for making end joints, lap joints or in making screens and storm windows.

The straight bit is recommended for rabbeting with a bit diameter slightly larger than the width of cut desired. The straight and circular gauge (shown in figures 1 and 3) is particularly adaptable for this type of cut. For smooth and uniform cuts, it's a good idea to attach a block of wood (see fig. 3) to the face of the straight edge of the gauge.

After placing the bit in the chuck and lowering to desired depth, attach the gauge and move toward bit until desired width of cut is reached. Make a preliminary pass on scrap stock, and after measuring to be sure of width and depth, proceed with the rabbit.

This is #1 in a series of "how-to-hints" by Stanley. Watch for them.

### RECOMMENDED TOOLS

The Stanley HANDICRAFTER. High speed (27,000 r.p.m.) router, complete—\$39.95

The Stanley Handyman Straight and Circular Gauge—\$2.00

The Stanley Handyman "Hi-Hone" Bit Assortment. 6 high-speed steel bits, carefully selected for maximum versatility with the HANDICRAFTER—\$12.80 the set

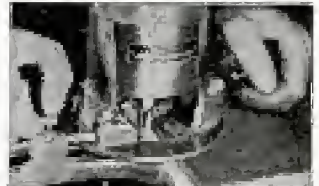

1. End Joints



2. Lap Joints



3. Screens & Storm Windows

## STANLEY | STANLEY

ELECTRIC TOOLS

HARDWARE  
TOOLS  
STEEL STRAPPING  
STEEL

Expert Craftsman or Woodworking Beginner  
... The New Router Book is loaded with lots more "how-to-do-it" know-how. Over 100 illustrations. Only 50 cents. Use the convenient coupon.

### STANLEY ELECTRIC TOOLS.

324 Myrtle Street, New Britain, Connecticut  
Please send me ( ) free literature describing the new Stanley HANDICRAFTER and Handyman accessories.

Please send me ( ) new Router Book (I enclose 50 cents).

Name .....

Address .....

City ..... State .....

**YOU**  
can OWN a  
*Cushman*  
**EAGLE**  
for as  
little as  
**\$500** per  
week!



**3/4¢ PER MILE  
TOTAL  
OPERATING COST  
UP TO 75 MILES  
PER GALLON**

Cushman's your biggest buy in fast, low cost transportation. For as little as \$5 per week you're set to go everywhere—ride to work, home, school, errands—hundreds of places and pleasures. No traffic or parking problems—no money worries either—low first cost—low maintenance—extremely low operating cost. Get set to GO—see your Cushman dealer for FREE demonstration.

See your Cushman dealer NOW for the world's best buy in low cost transportation

**CUSHMAN MOTOR WORKS, INC.** 916 No. 21st St.  
Lincoln, Nebr.



"It all began when she lost my Aladdin Angler vacuum bottle!"

*Aladdin*

VACUUM BOTTLES  
and LUNCH KITS



PINTS, QUARTS  
and WORKMAN'S  
LUNCH KITS

ALADDIN INDUSTRIES, INCORPORATED, Rochelle, IOWA

speed at which you will drive, of course.

**Q: How do you apply the brakes?**

**FITCH:** In a conventional sports car having normal brakes you use short, hard, interrupted pressures, backing off between applications to let them cool. Then you shift down to third gear so the engine can help stop you and you brake it two or three more times and shift to second. If you get down to second and the brakes begin to rumble or one of them grabs or you are going too fast to get into the corner and have to go down the escape road, then you know you have to start braking a little sooner next time.

**WALTERS:** It's as cut and dried as that. On each team, someone who knows what the car will do determines the exact procedure during practice. Drivers are then asked to follow his advice.

**FITCH:** Le Mans is not good for discussing driver technique because it is so cut and dried, as Phil says. That is why we say the car is so important there.

**Q: Is the technique different on the difficult circuit at Nurburgring?**

**FITCH:** I suppose not really, but there is more chance to use technique. There are more turns, which often run together and are complicated by positive and negative banking. And there are steep up and down grades. There, most of the drivers are familiar with the course and it is assumed that they know what to do. If they take the downhill section too fast and abuse the brakes, run too deep into the corners and have to stand on them too hard without any respite at all, in two or three laps the brakes start smoking, the lining begins to burn and they are out of commission.

**WALTERS:** It is entirely possible to destroy a car in 25 miles by the way you drive it. So, even in the so-called sprint races, the first thing a driver does is recognize the car's capabilities and stay within them.

**Q: What happened to you at Rheims, France, John?**

**FITCH:** I went off the road at 140 miles per hour and thought I would never stop bouncing. The Cunningham went end over end once and I don't know how many times it rolled.

**Q: That was the open roadster, wasn't it?**

**WALTERS:** Yes, it was the open Cunningham. The good roll-bar construction saved his life.

**FITCH:** I was conscious of trying to hold myself down in the car and of course I had a safety belt holding me in also.

**Q: Do you wear a safety belt when driving in competition?**

(Continued to page 292)



**BUILD IT  
YOURSELF  
AND SAVE**

# 3 Bedroom Home \$1990.

(MODEL 101)



## 2 BEDROOMS

(MODEL 102)

\$1735<sup>00</sup>

## 1 BEDROOM

(MODEL 103)

\$1385<sup>00</sup>

**PRE-CUT  
and  
PANELIZED  
for  
EASY ERECTION**

Plus freight and  
sales tax if any

**SAVE THOUSANDS of DOLLARS  
MOVE IN — IN 2 DAYS!**

**Satisfaction  
Guaranteed**

by one of the

**World's Largest  
House Manufacturers**

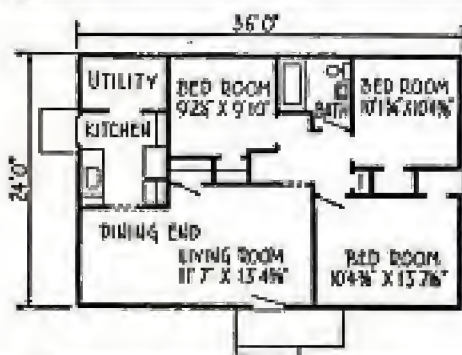

Plan No. 101. Size 36' x 24'. Living room, kitchen, utility room, 3 large bedrooms and bath.

Erect this home in 2 days with the help of a few friends—move in—then finish it at your leisure. Exterior walls fabricated with sheathing, builders' felt and asbestos shingles applied, in choice of colors. Windows installed, interior partitions assembled, erection drawings and specifications furnished and all lumber marked for easy erection.

Choice territories still open for representatives

SEND \$100

for PLANS  
and material list to:

**LUMBER FABRICATORS, INC.**

ECONOMY DEPT. A2 ♦ FORT PAYNE, ALABAMA



Trade where  
you see  
this sign



### Treasure - Minerals - COINS

Easily located with new Light-weight M-Scope Detector. Superior performance, lowest price, monthly payment plan.

FREE LITERATURE

**FISHER RESEARCH LAB., INC.**  
PALO ALTO CALIF.

## MODERN LAWN MOWER SHARPENER

Service departments of leading Lawn Mower manufacturers use the Modern Lawn Mower Sharpener. One lever moves lawn mower into grinding position. Gasoline and oil remain in engine while sharpening, no dismantling of wheels, roller or handle. The Modern is a precision bed knife grinder—no extra grinder to buy. Imitated but never equaled—Compare before you buy. If it isn't a Modern it can't be Modern. (Prices subject to change without notice)

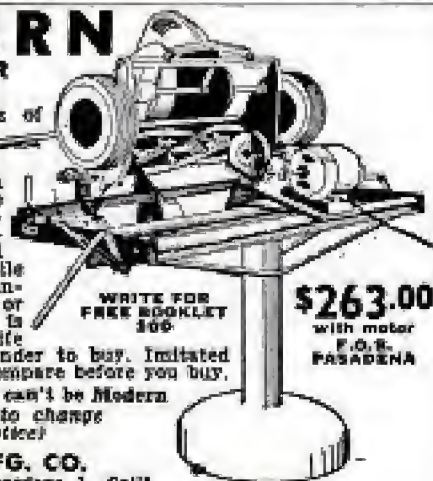

WRITE FOR  
FREE BOOKLET  
106

**\$263.00**

with motor  
F.O.B.  
PASADENA

**MODERN MFG. CO.**

180 N. Fair Oaks - Pasadena 1, Calif.

FEBRUARY 1954

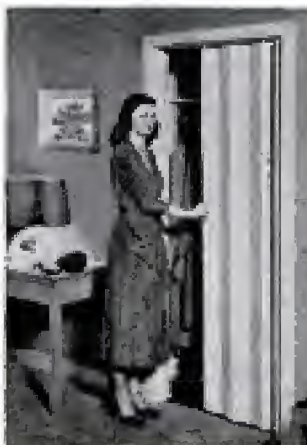

New!  
**Pella**<sup>®</sup>  
WOOD  
FOLDING  
DOORS

**Decorative • Convenient • Economical**

Now you can use the floor and wall space that swinging doors waste. Pella Wood Folding Doors fold compactly against the door jamb like an accordion. Ideal for closets, bedrooms, kitchen and as folding partition between living and dining rooms. Anyone can install, quickly, easily. Completely packaged with hardware, fittings, installation instructions. Heights to 10', widths to 30'. Natural wood finishes and unfinished. Investigate today!

CLIP AND MAIL TODAY

**ROLSCREEN COMPANY**  
Dept. F-16, Pella, Iowa

Please send complete literature and prices on Pella Wood Folding Doors.

NAME \_\_\_\_\_

ADDRESS \_\_\_\_\_

CITY \_\_\_\_\_

ZONE \_\_\_\_\_

STATE \_\_\_\_\_

# CUT PERFECT GROOVES WITH *Warren* WASHERS ON YOUR SAW BLADE!

You Just DIAL  
the Cut Wanted

over 250,000  
sets in use!

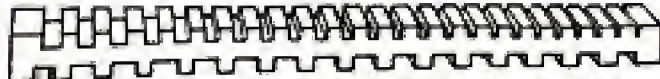

NOT ONE—NOT TWELVE—BUT  
40 DIFFERENT CUTS!

Warren Washers—engineered to cut clean, accurate, parallel grooves with your present power saw. 40 micromanic adjustments—just dial the desired width. Actually strengthens blade, eliminates vibration—leave on saw for straight cuts. No burning or chewing. Over 250,000 satisfied users in 48 States and many foreign lands. Be sure to get genuine Warren Washers . . . they're guaranteed!

FREE! Send for free descriptive booklet. Arbor sizes 1/2", 3/4", 3/8", 1". See your dealer or write direct.

**WARREN WASHERS CO.**

Dept. 22, Box 98, North End Station, Detroit, Mich.

ONLY  
**\$4.95**  
SET

MAKE it at home . . . with **HOMASOTE**



WITH OUR CONSTRUCTION PATTERN  
YOU BUILD THIS ATTRACTIVE

## STORAGE CHEST easily and at minimum cost

You build this storage chest in a weekend. Overall size is 11 cubic feet . . . ample space in top for linens, blankets, etc.; two full-depth bottom drawers. You use no blueprints to build this chest. Our simplified East-Bild\* Pattern #269 specifies all materials — shows how to cut each piece to exact size — how to assemble and decorate finished chest — like a professional.

The major material used is weatherproof Homasote — Type RD — 1 1/16" thick — permanently crackproof — one of the strongest building materials you'll ever use. Yet it saws, nails, takes paint or stain — just like wood. Mail the coupon for your pattern and Homasote literature.

\*T. M. Reg. East-Bild Pattern Company

HOMASOTE COMPANY, Dept. 25, Trenton 3, N. J.  
I enclose 50¢ for which send me Pattern #269.

NAME .....

ADDRESS .....

CITY..... STATE.....

My lumber dealer is.....

FITCH: I feel in most cars a belt is desirable when racing.

WALTERS: Wouldn't you say that in any car that you are protected in, it's a good idea? But if you are half sticking out, it is probably best not to have one on.

FITCH: Well, I feel that it may be desirable even in a car that you stick out of because you can loosen the belt. I don't say that you would, but you can loosen it with just one motion of the hand. In minor accidents, where you run off the road and the car stops suddenly but remains upright, you are usually safe if you are fastened in, but if you go flying unprotected through the air at high speed and hit a tree or anything solid, it's too bad.

Q: What attributes of a sports car should the American family car adopt?

FITCH: I would say less unsprung weight in the rear axle. It is not for any obscure sport or competition reason, but simply to make them more pleasant to drive and ride in.

WALTERS: I suggest that the car's ability to stop quickly from high speeds be improved. They can do it with bigger brakes, by cooling the brakes or by going to spot brakes.

Q: What would less unsprung weight do?

FITCH: It would keep the back wheels on the ground, the result being that the car would handle better, it would stay on the curves better and would be much more comfortable.

Q: What changes in design would be necessary?

FITCH: I would think the best system would be a trailing-link suspension.

WALTERS: With a sprung differential.

FITCH: Yes, it could also be done by de Dion or by sticking to present designs and using lightweight metals. ★ ★ ★

## Prestressed Concrete Girders Cut Building Costs

Prestressed concrete girders recently saved 20 percent of the construction costs of an 800-car garage in San Francisco. The beams use only 12 tons of steel cable and replace 180 tons of steel girders. The largest of the beams used is 68 feet long and weighs 120 tons. Four of these horizontal beams support the 700-ton load of three upper floors. Vertical supporting columns inside the garage are eliminated. The prestressed concrete girder is built by pouring concrete around a number of 1 1/2-inch steel cables stretched lengthwise in the form. After the concrete hardens, the cables are stretched with jacks to create a tension.



**Strip Paint EASILY**

## WONDER-PASTE

Wonder-Paste is different. Takes the hard work out of removing varnish, paint, enamel, etc. Softens up finish so it comes off easily — not coat by coat, but in one scraping. Stays put on upright surfaces. Use it on furniture, trim, floors, etc. At paint and hardware stores.

Write for leaflet and advice on your removing problem  
Wilson-Imperial Company, 119 Chestnut Street, Newark 5, N. J.

## SHEET METAL BRAKES

Angles, Channels, Pittsburgh locks, 24 G. steel, heavier aluminum. Cam locking, mount on bench, truck or floor stand. Truss braced steel. Express collect, 30", 37 lbs., \$28.50, 30", 35 lbs., \$23.00, 48", 100 lbs., \$48.00. Also 8 ft. size, Floor stand, 30 lbs., \$7.00, 15" capacity 16 gauge, 40 lbs., \$21.00.

IRON BENDER forms hooks, angles, coils, etc. Capacity 1/2"x2, \$9.50. ADJUSTABLE CLEAT FORMER, \$2.50. 30" CURVE FORMER, 16 gauge, any diameter, \$9.50. 3 1/2" Wide Flats, \$2.00. Fast 3/8" & 1/2" Punch, \$2.00.

(Immediate delivery. Order direct, cash or C.O.D., or send for folder.)

VYKE BRAKE CO., P-2439 15th St., Denver 11, Colo.

## TREASURE -- \$10,000

New locator detects metals, valuable minerals and buried treasure. Money-back guarantee of superiority.



Also grip counters. Govt. reward of \$10,000 for uranium discovery. Write for FREE information.



**THE GOLDAK COMPANY**  
1542 W. GLENDALE BLVD., GLENDALE 1, CALIF.

## LAWN ORNAMENT-NOVELTY PATTERNS

28 Lawn Ornament Patterns, 25c. Other Patterns: 15-20" high; Dutch Girl, Dutch Boy, Pirate, Bull Terrier, Mexican Girl, Mexican Boy, Dwarf, Penguin, Flower Girl, 15¢ each, 25 Novelty Patterns, 30¢. All 8 1/2 Full Size Patterns, \$1.00.

Strasher Pattern Service, Dept. 00-B, Box 133, Belington, W. Va.

## 15-inch Swing

Four inches more than other heavy-duty lathes. 33" between centers. Extra features. Compare SHOPSMITH! It's a saw, sander, vertical and horizontal drill, too. Write for free catalog.

SHOPSMITH, Dept. 259-B  
12818 Coit Rd., Cleveland 8, O.



**SEA LEGS** PRICES from \$39.00  
QUALITY BOAT KITS F. O. B. DEFIANCE, OHIO



12' UTILITY 14' RUNABOUT 8' SKIFF

**PENNEY WOODCRAFT INDUSTRIES**

1301-09 Ottawa Ave., Dept. 2-M Defiance, Ohio

## FINE WOOD DESERVES

*a fine*  
**OIL FINISH**



**Archer**  
*Pol-mer-ik*  
**LINSEED OIL**

- PROTECTS
- PRESERVES
- FINISHES

## AMONG ITS 101 Handy Uses

- Refinishing Antiques
- Glazing Windows
- Protecting Tool Handles
- Preserving Point Brushes
- Protecting Ladders

Yes, for preserving fine woods . . . and for an unending variety of other daily uses both indoors and out . . . you'll find Archer Pol-mer-ik the *handiest* single item in your home or shop.



**Is there a painter in the house?**

Archer Pol-mer-ik is the choice of most professional painters for paint reducing and brush conditioning. And with good reason . . . for Pol-mer-ik's special heat processing rearranges and locks together the oil molecules, giving you a tougher, more durable paint film than ordinary linseed oil. Paints reduced with Pol-mer-ik brush out easier . . . level better . . . establish a smoother surface that collects less dirt, and gives you a longer-lasting job! For better results, use Archer Pol-mer-ik *whenever you paint!*



**FREE!**  
**101 MONEY-SAVING IDEAS**

Get your copy today. Shortcuts and pointers from the "pro's", based on practical experience. Free—no obligation. Just drop a card to: Archer-Daniels-Midland Co., 603 Roanoke Building, Minneapolis, Minn.

BUILD AN  
**IDEAL**  
LAWNMOWER SHARPENER  
BUSINESS!

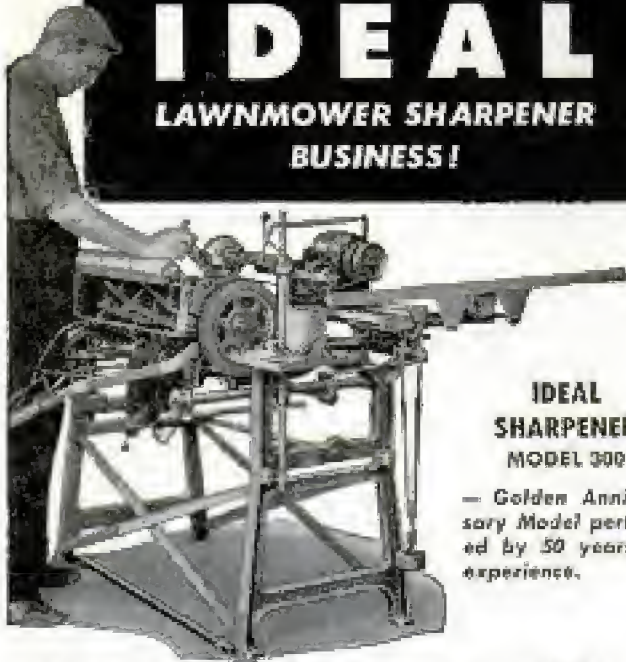

**IDEAL  
SHARPENER  
MODEL 300**

— Golden Anniversary Model perfected by 50 years of experience.

Build a profitable business of your own with the outstanding lawnmower sharpener—the IDEAL MODEL 300. Ruggedly built, easy to operate, sharpens all mowers without disassembly. Get your share of profits; write for information today.

**THE FATE-ROOT-HEATH COMPANY**

Dept. PM-2 — Plymouth, Ohio

send for **FREE CATALOG**

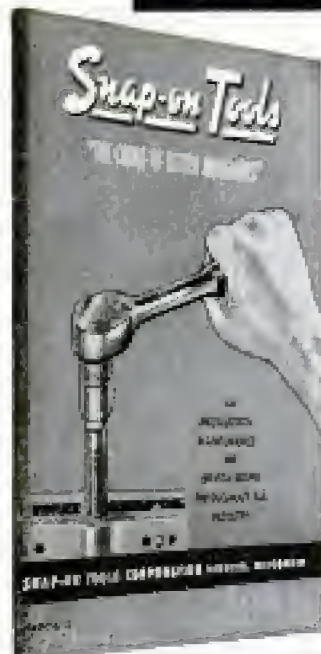

America's Foremost  
*money-making*  
**MECHANICS'**  
**TOOLS**

It's easy to own the same "pay-off" tools used and endorsed by America's top-earning mechanics throughout the automotive, aviation and industrial fields! Snap-on tools help you handle every repair job faster, easier, better. And they LAST... pay for themselves over and over again! Start building your own tool set now with basic Snap-on units—add others any time. Genuine Snap-on tools are never sold in stores—direct to users only. Mail coupon for free catalog.

**Snap-on Tools**  
THE CHOICE OF BETTER MECHANICS

Snap-on Tools Corporation  
8062-B 28th Ave., Kenosha, Wis.

Send me free catalog. Occupation \_\_\_\_\_

Name \_\_\_\_\_

Address \_\_\_\_\_

City \_\_\_\_\_ Zone \_\_\_\_\_ State \_\_\_\_\_

**Report to Detroit**

(Continued from page 171)

have become accustomed in the motorcar.

A four-passenger car seems to have no great appeal in the United States, despite its popularity in Europe. Nearly 60 percent said they would not buy a four-passenger car "under any conditions."

"A car of this size would not take care of my family." Ashton, Idaho, teacher.

"A one-car family could never take anyone with them."—Holcomb, Mo., teacher.

While automobile manufacturers seem to add more chrome each year to their new models, the owners say they don't like it. Only a tiny 9 percent said they want more chrome, while 32 percent specifically asked that less chrome be used.

"Remove all chrome and replace it with stainless steel."—Plainfield, N. J., plant executive.

"Keep design conservative, very little decoration and a minimum of chrome. Concentrate on comfort and safety."—Moncks Corner, S. C., engineer.

"Cut down on chrome, especially that which can reflect the sun into the driver's eyes."—Albuquerque, N. M., engineer.

On the average, the owners trade in their cars every three years. Only 9 percent said they traded to take advantage of new styling changes whereas 37 percent traded for mechanical reasons. Most owners (73 percent) see no sense in annual exterior style changes anyway.

"Car becomes outdated too soon."—Pawtucket, R. I., proofreader.

"New styles have too many bugs."—Kokomo, Ind., personnel representative.

When asked about features they would like to have in their future automobiles, the owners showed an amazing interest in the air-cooled engine—amazing when you realize there is no such automobile engine in production in this country today. The air-cooled power plant is the first choice for the "car of tomorrow" with 40 percent of the owners asking for it.

Second most popular feature for their car of tomorrow, according to the owners, is a rear engine. There are 22 percent of the owners who want that. These are the two most frequently picked mechanical changes.

As mentioned above, the most frequent suggestion the owners make to the manufacturers is that they build for greater safety. The second most frequent suggestion is that the cars should give better gasoline mileage.

"Instead of going overboard on this horsepower race, they should develop an

(Continued to page 296)



# Moody Kits

The Most Practical and Fascinating small tool sets in the world. Regardless of your sport, hobby or trade, you'll find a Moody Kit that is perfectly suited for small precision work and does your job right. Perfect for:

**Cameras, Guns, Fishing Reels, Model trains, Boats, Airplanes, Sewing machines, Eye glasses, Carburetors, Electric razors, Canvas, Rope and Sail sewing**

Screwdriver Kit (3" high) shown contains five tiny blades sizes .100", .80", .70", .55", .40" and chuck type handle. Write for free folder that completely describes all Moody Kits. You can buy them from your dealer or postpaid from:

**Moody MACHINE PRODUCTS CO., INC.**  
32 Dudley Street, Providence 5, R. I.



## MAGNETS 225 lb. PULL

GENUINE ALNICO - NEVER WEAKENS

**AMAZING, PERMANENT MAGNETS—WILL NOT WEAKEN! NON-ELECTRIC**

Retrieve guns, tackle, tools and other steel items from lake, river, plating tanks, drains or other hard-to-reach spots. Recover drills, taps, etc. from sweeping. Clear away of harmful ticks, nails. Many other uses. Pays for itself quickly. **GUARANTEED**. Try any magnet one week. Money refunded if you are not well pleased.

No. M-725 (Weights 54 oz.) Has pull of 225 lbs. on steel block. \$18.00  
 No. M-875 (Weights 40 oz.) Has pull of 175 lbs. on steel block. \$10.50  
 No. M-900 (Weights 42 oz.) Has pull of 150 lbs. on steel block. \$ 8.50  
 No. M-900 (Weights 1 1/2 oz.) Has pull of 50 lbs. on steel block. \$ 4.00  
 No. M-30 (Weights assortment of six small magnets) . . . . . \$ 1.50

Send Money Order or Check. We pay postage. No C.O.D.'s.  
**MIAMI MAGNET COMPANY, 3240 N. W. 27th Ave., Miami 42, Fla.**



### BUILD FINE GRANDFATHER CLOCK NOW

The simple, sensible, Ben-Kut way to thousands here — **SAVE REAL SHOP TESTED PLANS "SPIRIT OF THE CENTURY" Noddy's "Wrist 83" tall on stately straight side "SPIRIT OF AMERICA." EASY-TO-FOLLOW step-by-step PLANS tell all—plus BROCHURE of heavy brass weight Westminster, tube chime, movements, progress dials, 3 1/2" solid mahogany case kits. Send \$1.00 today — Both plans \$1.50 NOW.**

**KUEMPEL CHIME CLOCK CO., 27 Kuempel Bldg., Minneapolis 10, Minn.**



### make your own Gems 29.50 C.O.D.

The Gem Maker comes complete with all necessary equipment, including a super-charged diamond blade for sawing, and all wheels for grinding, shaping and polishing; also complete instructions. The complete equipment as shown, less motor and belt, for only \$29.50, f.o.b., Burlington, Wisconsin. Write today for information and literature.

**B&I MANUFACTURING CO.**  
Dept. S Burlington, Wis.

SAY YOU SAW IT IN POPULAR MECHANICS

# FREE Garden Tractor CATALOG

Big heavy-duty models—low cost utility models. All attachments including plow, sickle bar, cultivator, mower. Safety reverse. Quick starting. Rugged construction. Write for free catalog.



Quick Mfg., Inc., 3257 E. Main St., Springfield, O.  
**Springfield GARDEN TRACTOR**

## new type ALUMINUM

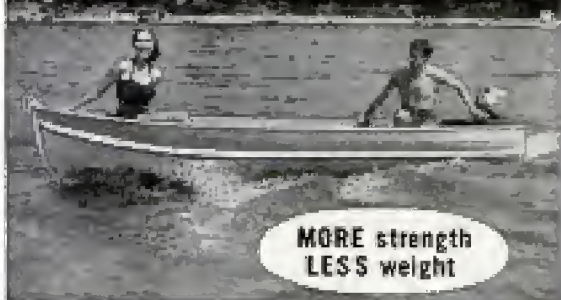

**MORE strength LESS weight**

### ONE PIECE BOTTOM CONSTRUCTION new features eliminate upkeep

Here's the boat you've always wanted. It's different! Eliminates upkeep problems... even painting. Entirely new design of durable aluminum. Strong, rigid, seaworthy—yet lightweight! No leaky, ugly bottom seams. Easy to load, easy to row. Compare feature for feature and you'll choose Starlite.

WRITE FOR FREE 1954 CATALOG

## STARCRAFT

Dept. G-2, Goshen, Ind. **METAL BOATS**

# WAKE UP

to a Warm House — with the



the "MAGIC BRAIN" that saves you up to \$40\* on fuel each year!

**ONLY \$12.95**

## PARAGON Nightrol

Here's how the Nightrol works for you!

**Every Morning.** Automatically turns up heat before you awake. Lets you dress in warm comfort.

**Every Night.** Automatically turns heat down 6° to 10°. Keeps home cooler for greater comfort while you sleep. Saves up to \$40 on fuel each year.

\*According to Government Surveys. Install it yourself! It's easy! Timer plugs directly into convenient electric outlet. Set back unit attaches directly into thermostat. Then set it and forget it . . . that's all there is to it. Approved by U.L. as a safe appliance for the home.



ENJOY ECONOMICAL AUTOMATIC HEAT CONTROL . . . MAIL COUPON TODAY

PARAGON ELECTRIC CO., Dept. PSE101, Two Rivers, Wis.  
 Please send me complete information on Paragon Nightrol.  
 Please send me a Paragon Nightrol. Enclosed is check or money order for \$12.95.

Name.....

Address.....

City.....Zone.....State.....

© 1953

**PIONEER WORK SAVERS**  
NOW BETTER THAN EVER—GREAT NEW 1954

**SHAW**  
"DU-ALL"

**Garden and Small Farm Tractors**

Plow.. Cultivate.. Mow.. Rake.. Bulldoze..  
Saw Wood.. Make Many Other Hard Jobs Easy

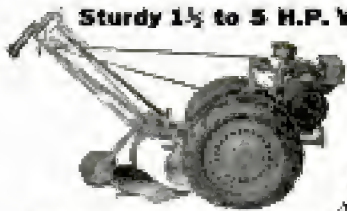

**Sturdy 1½ to 5 H.P. Walking Tractor**

Best for all around garden and lawn work. Variable speeds, adjustable wheel widths, individual gang tool controls. 3 speed and reverse automotive

gears on 3 and 5 H.P. models. Superb traction, deep plowing, easy handling. All wanted tools and attachments.

**Rugged, Low Cost 2½, 5, 8 H.P. Streamliner**

Powerful, practical, streamlined, comfortable. Pulls 8, 10, 12 inch plows, cultivators between 38" rows, bulldozes, mows lawns, operates belt attachments. 3 speeds and reverse automotive transmission. Friction brakes. ¾ to 7 M.P.H. Nothing else like it in a tractor that will get the work done.



**Inexpensive New Tiller... Lawn Mower**

Nine inch rotor pulverizes 12 inch swath 6 inches deep. 1½ H.P. Extremely low cost. Rotor quickly replaced with single wheel for lawn mowing, hauling, etc.

Also larger 8, 12 H.P. riding tractors with 3 speeds and reverse automotive gears.



See the SHAW Dealer Write direct for FREE CATALOG complete Shaw line.

**SHAW MANUFACTURING CO.**  
4502 Front St., Galveston, Kansas  
668-6 N. 4th St., Columbus, Ohio

Reach it easier with  
**the MAGNETIZED RE-CHUT**



This new handy magnetic tool will prove to be one of the most versatile in your tool kit. The slotted head is perfect to grab nails—any size—and hold them in exact driving position, in hard-to-get-at places. It can't be beat as a metal retriever—the narrow head and 7¾" over all length enable you to get into transmissions and other housings where your fingers can't reach. In fact, the ingenious craftsman will find a thousand uses for this sensational, inexpensive tool. Send for your Re-Chut today...

Only **\$1.00** Postpaid.

WRITE TODAY AND ASK FOR YOUR CLOSEST HUNTER DEALER—OR—ORDER DIRECT FROM THE MANUFACTURER. SATISFACTION OR REFUND GUARANTEED.



Have you ordered your SMITTY Driver for Allen Heads?—Every mechanic needs one.

GET YOURS TODAY—**\$1.50** postpaid.

**HUNTER TOOLS**

BOX 7395 LUGO STATION • Los Angeles 23, California

engine with fuel economy in mind."—Los Angeles photographer.

"Build lighter but not smaller cars with much smaller but more efficient engine and transmission with consequent economy to the owner and less wastage of our natural resource—petroleum."—Washington, D. C., technician.

Owners in large numbers also suggest that car makers deliver their products to the buyer in better condition, with more attention to details of assembly.

"Better materials and workmanship. Modern cars—even in higher price ranges—tend to use inferior materials. Factory workmanship is sloppy. Too much repair by the dealer is necessary"—Klamath Falls, Ore., industrial-relations adviser.

"More rigid inspection in final assembly. Slipshod work is inexcusable."—La Habra, Calif., machinist.

There are many other interesting facts that the survey disclosed. These are presented in detail in the percentage charts that accompany this article.

Only 50 percent reported that automatic transmissions are worth the extra cost. Yet Detroit is predicting that in a few years, all cars will have automatic transmissions. Power braking is second in popularity with 33 percent, 22 percent approve power steering. Reclining seats (available in only one make of car today) are desired by 24 percent of the owners. Evidence of the increased interest in safety is the fact that 14 percent of the owners are willing to pay \$50 extra for an automatic headlight dimmer to help reduce night hazards.

As in all our Owners Reports there are many remarks that are interesting even though they do not necessarily reflect a frequently held view.

"All cars should have a passing gear for emergency use."—Charleston Heights, S. C., Navy chief.

"Electric windshield wipers on all cars."—New London, Conn., retail salesman.

"Remove steering wheel as a vision and collision hazard."—Jamaica, New York, engineer.

"Make a grille that is easy to clean. There are too many places you can't get with a sponge or your hands."—Salem, Ore., printer.

"Provide a windshield free from interior reflections."—Franklin, N. H., field man.

"Stop spending millions on the horsepower race and spend a like amount on suspension and steering so that cars with 200-horsepower engines will be safe to drive."—Huntington, W. Va., salesman.

"Simplify engine design, keeping in mind the man who has to service the engine after

(Continued to page 298)

# SHOP BY MAIL & SAVE SURPLUS BARGAINS JUST RELEASED

## A. C. ELECTRIC GENERATORS

Power these electric generators with your own gasoline engine, power take-off, or electric motor, and save the difference.

**ITEM #20-3-3400 Watts, 120 Volt, 60 Cycle, 1200 RPM.** Single and three phase, for two or three wire circuits. Excellent source of electricity for portable or stand-by use for homes, farms, hospitals, radio stations, factories. Built by Holart Mfg. Co. to exacting specifications of the U.S. Army. Built bearing, generator, fan cooled. Equipped with standard 1 1/2" shaft with keyway for direct or pulley drive. Built-in Self-Exciter Ford Mounted, Gov't. Acquisition Cost: \$325.00. Ship. wt. 200 lbs. **155.00** P.O.B. Chicago. New Low Price.



**ITEM #20-75**  
 110 Volt, 60 Cycle, 1800 R.P.M. single and three phase current, for 2 or 3 wire circuits electric generator, double ball-bearing construction, standard 1 1/2" shaft with keyway, and included no extra pulley. 4 1/2" iron pulley for belt drive. Direct connected Self-Exciter Ford Mounted, Gov't. Acquisition cost: \$345.00. Dim. 14"x11 1/2". Ship. wt. 420 lbs. Price slashed to: **269.00** P.O.B. Chicago.

## PORTABLE ELECTRIC LIGHT PLANT

Compact Electric Plant suited for small homes, cabins, campers, hunting and fishing camps, trailers and small electrical home uses. Operating costs: About 5c per hour. Runs exceedingly quiet. Sturdily constructed for dependable service. Net weight only 88 lbs. Can be carried from place to place, or transported in trunk of car.



**350 Watt-110 Volt-60 Cycle-A.C. Model-3L8, 3L-3, made by Midco Mfg. Co. 1 Cylinder, 4 Cycle Engine cone plate with muffler, starting rope and oil bath air cleaner, direct coupled to a 350 Watt Generator with voltage control rheostat and twin outlets. Engine speed 1800 R.P.M. Shipping weight 130 lbs. Commercial List Price \$250.00. NOW ONLY **89.00** P.O.B. Chicago.**

## D. C. GENERATORS

**ITEM #21**  
 Type S-1, rated 300 Amps.-30 Volts. Mfd. by Jack & Heitz, Gov't. Acq. Cost \$380.00. Ship. wt. 25 lbs. Dimensions 10" x 10" x 7". P.O.B. Chicago. **35.00**

**ITEM #20-1** Type P-1, rated 200 Amps.-28 Volts, 2500 RPM, Mfd. by General Electric, Ford, DeLco-Remy and Westinghouse. Gov't. Acq. Cost \$300.00 Ship. wt. 25 lbs. Dimensions 13"x8"x4". P.O.B. Chicago. **22.50**

## ROSS 4-WAY FOOT OPERATED AIR VALVE

**ITEM #240**  
 BRAND NEW - For double-acting pneumatic cylinders. Fine for operating presses, air lines, air machinery of many types. Heavy duty cast construction. No neutral position. Maintains pressure against the piston when the foot control is in the "Up" position. Threaded for 1/2" pipe. Dimensions of valve body: 7 3/4" long x 4 1/4" width x 7 1/2" high. Net weight 28 lbs. A \$24.00 value for only. **19.50** P.O.B. CHICAGO.

## EXTRA HEAVY DUTY Double Action HYDRAULIC CYLINDER

**ITEM #224, 3 1/4" bore, 2 1/2" stroke.** With 1150 lbs. W.P. WITH 3000 P.S.I. line pressure. 1 1/2" pipe thread ports - 1 1/2" diameter ground, polished and plated gold steel shaft. Overall length closed 30". 1 1/2" steel wall cylinder barrel clevis mounting at base and shaft. Pressure-Tie Rod construction. Honed barrel. Ship. wt. 34" lbs. P.O.B. Chicago. **39.60**

## BRAND NEW! JUST RELEASED! BLACKHAWK HAND-HYDRAULIC PUMP

**ITEM #22.** Perfect for Hydraulic Presses, Snow Blows, Farm Wagons, Jacks, and Farm Hoists. A few easy strokes of the 20" handle and you can lift 5000 lbs., using Item 225 - Hydraulic Cylinder. Blackhawk Model P-151 - complete with built-in oil tank and release valve. Rated 1200-2400 lbs. per square inch. Dim. 17"x7"x6". Ship. wt. 25 lbs. World's most money. P.O.B. Chicago. **22.50**

**FREE WINTER EDITION**  
 1954 CATALOG, 52 PAGES, check full of unsurpassed War Surplus Equipment Bargains for farm, home, factory and workshop. Write today.

## GOV'T. SURPLUS! JUST RELEASED! 2-TON, 6-WHEEL HYDRAULIC LIFT TRAILERS

USE FOR: Conveyor ramp • Boat trailer • Lumber • Pipe • Pole trailer • Machinery trailer • Hydraulic dump for 2 1/2-ton wagon • Coal truck • Lift truck • Variable height hydraulic work table • Removable rack permits use of hydraulic lift for other installations. Outstanding features of these trailers are: -4000 lbs. pay load. 2 individual hydraulic lifts complete with hand pumps and valves. -18"x5.5 pneumatic tires included. Manual screw-down brakes. Ball-bearing axles. V-shape load rack-8' long. Towing tongue. 54" lift. Wheelbase 98". Ground clearance 4 1/2". Tread width - 52". Overall width-38". Overall length included -167". Gov't. cost \$885.00. Ship. wt. 1400 lbs. P.O.B. Chicago. **169.50**



## HYDRAULIC SPEED REDUCER with FINGERTIP CONTROL

USE FOR: • Reamer Drives • Budget Cars • Feed Mills • Canning Machines • Conveyors • Lathes • Milling Machines • Motor Boats • Cream Separators • Garden Tractors • Pumps. Variable output speeds from 0 to input speed available by moving control handle. Locking handle maintains setting. Use input power of 3/4 to 1 1/2 H.P. This Westinghouse-Gil Gear Unit consists of a variable displacement hydraulic pump feeding a fixed displacement hydraulic motor. Adjustable relief valves set at factory for 100 inch pounds of torque may be reset up to 180 inch pounds. Independent reverse control allows full output power and speed selection in either direction of rotation. Shaft measure 3/4" diam. Include keyway. Input rotation is counter-clockwise facing shaft. Recommended input speed not to exceed 750 R.P.M. Overall dimensions, 7 1/2"x7 1/2"x11 1/2". Gov't. acquisition cost, \$42.00. Ship. wt. 31 lbs. Complete with 2 qts. of oil and full instructions. P.O.B. Chicago. **54.50**

## DOUBLE ACTION HYDRAULIC CYLINDER

**ITEM #355** - 2 1/2" bore and 1 1/2" stroke. 1 1/2" stainless steel piston rod. Lift capacity 3000 lbs., using 1000 lbs. pump pressure. Manufactured by DeLco-Remy Division of General Motors Corporation. Clevis mounting on base and piston rod for 1 1/2" hole. Overall length closed 21". Distance between centers 18". Equipped with fittings to 3/8" pipe thread. Brand new - in original carton. **16.00** P.O.B. Chicago.

**ITEM #355A** - Same unit, but supplied with built-in spring to provide cushion effect on lower stroke and rapid return. **17.00**

**ITEM #16-C** - Double acting hydraulic cylinder, 1 1/2" bore, 20" stroke. Will lift 1700 lbs. with 1000 P.S.I. line pressure. Weight 8 lbs. A \$25.00 value. Now only... **16.95** Postpaid

## PUROLATOR OIL FILTER

**ITEM #76** - A perfect permanent element oil filter to keep your motor oil or hydraulic fluid clean at all times. Protect your pump or engine with this unit. Just turn the handle and the element is clean. Standard 3/8" inlet and outlet ports accommodate 20 gallons per minute. Shipping weight 4 lbs. \$24.00 value. NOW ONLY... **5.95** Postpaid

## SAVE \$30.00 ON THIS Brand New - Peeco HYDRAULIC CONTROL VALVE

FOR SAFE POSITIVE CONTROL OF HYDRAULIC CYLINDERS AND MOTORS - • BUILT-IN RELIEF VALVE - factory set at 1200 P.S.I. • FOUR-WAY VALVE - to operate one double acting cylinder • OPEN CENTER - with valve in neutral, cylinder is locked in position and pump is unloaded. • SPRING RETURNS TO NEUTRAL • FULLY BALANCED PLUNGER • EASILY STACKED INTO 2, 3, or 4 valve combinations for multiple cylinder operation. • 8 gal. per min., capacity. At 1200 P.S.I. - 5/8" pipe ports. • EXCESSIVE PRESSURE SHUTS TO HAND & FOOT REMOTE CONTROL. • EASY MOUNTING • LIST PRICE - \$46.00 • YOU SAVE \$30.00. DIMENSIONS - 11"x4 1/2"x2 1/2". Ship. Wt. - 8 lbs. P.O.B. Chicago. **16.50**

## BRAND NEW - BERRY HEAVY DUTY HYDRAULIC PUMP OR MOTOR

**ITEM #16** - use on farm equipment, road machinery, vibrators, paper mills, wire reels, hydraulic brakes, ball bearing construction. Excellent cam design assures high efficiency performance. When used as a pump: delivers 11 G.P.M., 1000 P.S.I., 8 H.P. At 1800 R.P.M. is a HYDRAULIC MOTOR: Rated up to 12 H.P., up to 2400 R. P. M. Standard 3/4" pipe thread ports, 3/4" shaft with keyway. Dimensions: 14 1/2" x 7 1/2" x 7 1/2". Weight 63 lbs. Regular price today \$22.00. Our money saving price P.O.B. Chicago. 3 for \$10.00. Each **59.50**

## CENTRIFUGAL PUMP

GENERAL MOTORS - ALLISON  
**200 GALLONS Per Minute**  
 • For Draining Basements  
 • Fire Fighting  
 • Irrigation  
 • Fuel Transfer  
 • Swimming Pools • Home Water Systems • Dewatering

For high volume commercial, home and industrial use. Standard 2 1/2" pipe thread inlet, with 1 1/2" pipe thread outlet. Ball bearing supported 1/2" shaft. Large priming floatball, counter-clockwise turning shaft. Gov't. acq. cost \$145.00. Complete with full instructions. Ship. wt. 25 lbs. P.O.B. Chicago. **39.50** Will deliver 200 gals. per min. at 3000 R.P.M. using 5.2 H.P. at 3000 R.P.M.

**TO PLACE PHONE ORDERS CALL Webster 9-3793**

ORDER DIRECT FROM AD - SEND PAYMENT OR PURCHASE ORDER TODAY - SATISFACTION GUARANTEED

# GROBAN SUPPLY CO. 1139 SO. WABASH AVE., CHICAGO 5, ILL. DEPT. PM-2

# Simpson Model 260

VOLT-Ohm-MILLIAMMETER  
\$38.95 Dealer's net.

USE IT FOR:

- TV SETS
- RADIOS
- TRANSMITTERS
- BROADCASTING EQUIPMENT
- HOME APPLIANCES
- TWO-WAY RADIO COMMUNICATIONS SYSTEMS
- PHONE LINES
- AIR CONDITIONING SYSTEMS
- STARTER CONTROLS
- AUTO IGNITIONS, GENERATORS, BATTERIES
- MOVIE EQUIPMENT
- PANEL INSTRUMENTS
- TV CAMERAS
- AUTO LIGHTING SYSTEMS
- GENERATORS
- VOLTAGE SOURCES
- "HAM" RADIO EQUIPMENT
- CABLES
- CONNECTORS
- AUDIO FREQUENCY SOUND CURRENTS

...and send 10c for your copy of  
"1001 Uses for the Simpson Model 260"  
50 pages of uses.

BEST ALL-AROUND TESTER ON THE MARKET



BEST ALL-AROUND TESTER ON THE MARKET

RANGES:

- 2500 OHMS PER VOLT DC
- 1.50 OHMS PER VOLT AC
- VOLTS, AC AND DC: 2.5, 10, 50, 250, 1,000, 5,000
- CURRENT, I.S. 10, 50, 250, 1,000
- MILLIAMPERES, DC: 10, 500, 500
- AMPERES, DC: 10
- DECIBELS (5 RANGES) -32 TO +35 DB
- OHMS: 1-200 (33 OHMS CENTER), 5-200,000 (12,000 OHMS CENTER), 5-25 MEGOHMS (130,000 OHMS CENTER)

SIMPSON ELECTRIC COMPANY  
5200 W. Kinzie St., Chicago 44 - ESTebrook 9-1121  
In Canada: Bach-Simpson, Ltd., London, Ont.

the body has been put around it."—San Antonio, Tex., farm-equipment dealer.

"Build in a one-shot lubrication system."—Grafton, N. D., minister.

"Too much emphasis on styling. Who cares how a car looks just so it's safe and gets you where you want to go, comfortably and safely?"—New York City salesman.

"Have front and back floors level instead of raised in the middle."—Waterloo, Iowa, carpenter.

"Make steering ratio lower and cornering better."—Centralia, Ill., engineer.

"I do not believe in forsaking the safety features of the older cars just to accomplish a rakish style, as some manufacturers seem to be doing."—Albuquerque, N. M., administrator.

Finally, the owners were asked to give their opinion of the foreign car, a subject of much discussion these days.

They are obviously not impressed by what the Europeans are doing despite the fact that the air-cooled engine and rear engine that the owners want in their future cars are fairly common in Europe today.

Only 19 percent had anything at all favorable to write about imported vehicles. The majority (55 percent) were definitely opposed to the foreign car for various reasons, ranging from a belief in American mechanical superiority to a feeling that we should trade at home to protect our standard of living.

"I prefer getting into a car, not putting one on like a vest."—Miami, Fla., executive.

"I believe in patronizing the home market first under any circumstances and believe foreign cars are a fad for those who want to be different."—Shaker Heights, Ohio, accountant.

"All right for European cities where the streets are all narrow. We are a people who like more room and comfort."—New York City contractor.

"Okay for playboys."—New York City banker.

"Not so modern as ours. They are years behind in styling. The good foreign car is excessive in cost."—Bremerton, Wash., master mechanic.

"Owners seem to make foreign cars a hobby rather than an essential means of transportation."—Baxley, Ga., forester.

There you are, Detroit. That is what a cross section of the automobile market thinks about you and your competition. Naturally, every one won't agree with the results of the survey, but the replies do prove that Americans are more auto-conscious than ever. A careful reading of the percentage tables will give all of us, and especially the manufacturers, something to think about.

★ ★ ★



# Start your collection of FINE TOOLS

with this

## BONNEY SOCKET SET!



Here's the most practical basic socket set for home and shop. It contains twelve of the most useful  $\frac{1}{2}$ " square drive double-hex sockets, together with a 15" hinge handle and an 8" cross handle. Available in either a cardboard or metal box.

With this Bonney Socket Set, you can make quick work of repairs and adjustments on lawn mowers and garden tractors, automobiles, washing machines and other household appliances.

Take a tip from professional mechanics who call Bonney wrenches America's finest—make Bonney *your* choice. Start with a Bonney No. AA8 Standard Series Socket Set. Then add to your collection of *fine* tools from time to time by buying the Bonney wrenches *you* find most useful. They're available in open stock or complete sets. Ask your dealer for Bonney. If he doesn't have the No. AA8 Socket Set in stock, he can get it for you. Or write us direct.

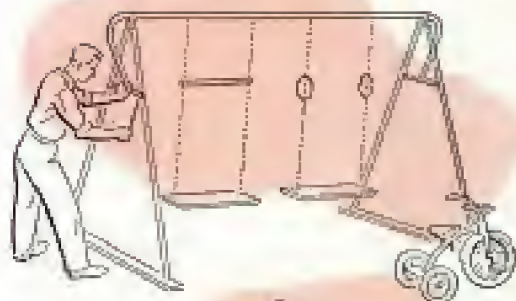
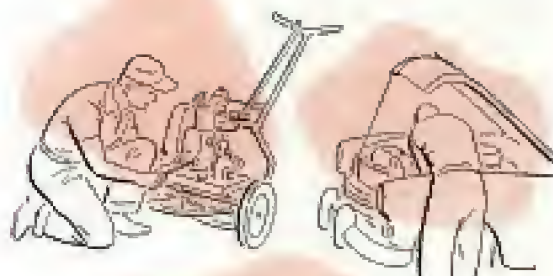

*Note!* The economy-minded home mechanic or hobbyist will find Bon-E-Con tools especially suited to his requirements. They are tools any man would value at prices anyone can afford. And Bon-E-Con tools carry the same guarantee as Bonney tools.

BONNEY FORGE & TOOL WORKS, ALLENTOWN, PENNSYLVANIA

FEBRUARY 1954

299

Copyrighted material

# NEW!

## Giant 1954 148 PAGE Catalog of AUTO PARTS & ACCESSORIES



World's Largest Selection... Everything for Your Car, Truck, Custom-styled Car, Hot Rod

# YOU SAVE UP TO 50%!

50,000 Items... all at WHOLESALE PRICES!

It's ready now... the only complete buying guide to everything you need for your car, truck, custom-styled car, or hot rod... at rock-bottom wholesale prices! Thousands of hard-to-find parts... equipment and replacement parts for cars from 1920 to brand new 1954 models! New Hollywood accessories not offered in stores; high-speed parts to pump up your engine; custom-styling equipment to give your car that "expensive" look. Speedy shipment, guaranteed satisfaction, and money-saving wholesale prices!

**FREE** If you mail coupon today, we'll send valuable Check Chart that shows you how to know if your car is safe... may save you hundreds of dollars in repair bills... **YOURS FREE** when you mail coupon for Catalog.

**MAIL THIS COUPON TODAY!** Get your J. C. Whitney Catalog NOW! Mail coupon with 25c to help pay postage and handling. We'll credit the 25c on your first \$5.00 minimum order, and the Catalog will be **FREE TO YOU!** Mail Coupon TODAY!

**J. C. WHITNEY & CO.**  
1917 P-2 Archer Ave., Chicago 16

Here are just a few of our 50,000 items



- Auto radios
- Hi-Speed Equipment
- Mufflers, pipes
- Engines, parts
- Transmissions
- Custom-Style Acc.
- Tires, tubes
- Tools
- Springs, shocks
- Ignition parts



### Light-Powered Clock

Light energy powers a Swiss clock that will run for a full day after an hour's exposure to natural or artificial light. Light streaming through the translucent top activates a photoelectric cell which feeds a miniature motor that winds the main-spring. It will store four days' power.

### Interceptor Waste Trap

Several advantages are claimed for an interceptor waste trap of unique design. Jewelry and other solid objects which wash down the drain are caught in a filter-bottomed retriever. Food particles caught in the retriever are soon dissolved and washed away by the strong currents which flow in, out and through it.

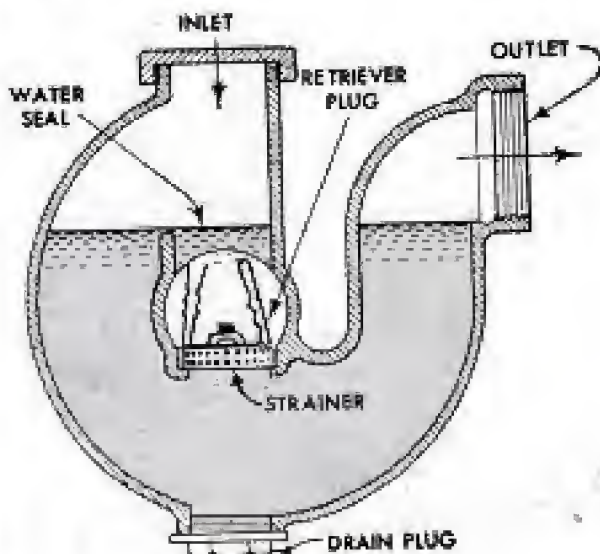

**J. C. WHITNEY & CO.**  
1917 P-2 Archer Ave., Chicago 16, Illinois

Rush giant 1954 Catalog of auto parts and accessories at wholesale prices. I enclose 25c to cover part of cost, which will be credited to me on my first \$5.00-or-more order.

Name.....

Address.....

City..... State.....

IF YOU WANT  
BARGAINS...

# T&T HAS THE TOOL BUYS!



## 1/2 SHANK HIGH SPEED DRILL SETS

Fractional size precision drills with 1/2" shanks for use in 1/2" drill, drill press or lathes.

**SET 32**—5 fast-cutting drills from \$9.55

1/2" to 1-3/16". Postpaid.....

**SET 33**—10 high speed drills \$17.40

sizes 1/2" to 1-3/16". Postpaid....



## RECONDITIONED H.S. REAMER SETS

**SET 16N**—20 different size straight shank

Chuckling Reamers up to 1/2" — \$9.49

our low price.....

**SET 18N**—15 different size straight shank

Chuckling Reamers from 1/4" to \$9.49

1" — only.....

**SET 25N**—15 different size Morse Taper

Chuckling Reamers to 1/2" — \$9.49

No. 1 & 2 Tapers.....

THESE SETS SENT POSTPAID



## 8-PC. HIGH SPEED SLITTING SAW SET

**SET 34D**, 7 different H.S. slitting saws

plus mandrel for 1/4 or 1/2" drills.

2 3/4" dia.—1" arbor—.040 to .071 \$4.95

thick. Cut wood, metals, plastic. Postpaid.....



## HIGH SPEED KEY-SEAT CUTTER SET

**SET NO. 4**—5 sizes. Can be used as mount-

ed milling cutter or circular saw.

1/2" shanks—widths to 3/4". diam-

eters up to 1". Mix of new and \$3.95

resharpened. Postpaid.....



## 12 MIXED INDIA STONES

A mix of 12 stones, for use in clearing

corners, edges, etc. where stock \$3.50

must be removed without scratching. Various sizes and shapes. Our price, postpaid..



## AIR FORCE SURPLUS RHEOSTAT

Designed for heavy duty with air

force heated suits. An ideal

unit for regulating voltage

on heavy duty equipment

such as welders. A real \$2.50

buy. Postpaid.....



## 2 H.P. ELECTRIC MOTOR

24 V. 90 Amp. ball bearing motor

with double end 1/2" 11 spline shaft.

Can be used on 110 AC \$9.95

by changing internal leads

— instructions on request. F.O.B. Detroit.....



## NEW 1/20 H.P. CONT. DUTY MOTOR

110 volt, 60 cycle A.C.—1750 RPM.

Ball bearings, 1/4" shafts—weight

3 1/2 lbs. New, guaranteed \$4.95

— ideal for fans, other continuous duty uses.

Postpaid.....



## 10 RPM ELECTRIC MOTORS

For slow motion displays, toys, rotating

TV antennas, etc. 24 volts—oper-

ates on 110 with resistor

which is included. Single or \$4.49

twin 3/16" shaft, 5" high. Postpaid.....

Orders under \$5.00, add 50c for handling. Orders from outside U. S. must be accompanied by added 25% of total order for added shipping costs.

## SEND 10c FOR OUR BIG NEW

### CATALOG

listing thousands of surplus tool and equipment bargains at prices far less than you would ordinarily expect to pay. Write today requesting Catalog M2.



## FILE MIX \$3.69

Set of 12 differ-

ent used files in

good, usable condition.

Various sizes—lengths up

to 12" — half rounds,

knives, bastard, mills and

others. Postpaid.



## SPRING MIX \$2.98

5 lbs.—all types

included from 1/2"

to 6" long. Includes com-

pression, expansion, toy-

sion, furniture, and many

other kinds. All in original

condition. Postpaid.

## RESINOID BOND GRINDING WHEELS

Save 85%! 8" dia., 3/8" bore. New, fast

working. Perfect for welders, machine

shops, hobbyists. Postpaid.....

1/4" Thick. \$1.10 3/8" Thick. \$1.20 1/2" Thick. \$1.35

## GRINDING WHEEL MIX

30 new grinding wheels, all types and sizes,

up to 2" diameter, with 1/4" arbors.

Mandrel included which fits all

wheels. Use in drills or flexible

shafts. Postpaid.....

## 5 LBS. BALL BEARINGS

Standard size free running ball

bearings, accurate within .0003, 14

bearings—7 matched pairs, 3/8" to

2 1/4" O.D. Made for aircraft. Postpaid

## ADJUSTABLE RELIEF VALVE

Pressure relief valve for protecting hydraulic

systems using positive displacement

pumps. 2 inlet and outlet

ports—can be connected without

pipe tee. Uses 1/2" tubing fittings. \$4.95

## MULTI-PURPOSE PUMP

3 independent sections in one shaft for

single or multiple pumping. Use one as vac-

uum capable of drawing 25" of mercury.

Others can be used for power

spraying, draining, etc. Each section

standard 1/2" pipe threads. Postpaid

\$8.95

3 1/2" Size, per ft....35c 1/2" Size, per ft....45c

Male Fitting....\$1.25 Male Fitting....\$1.50

Female Fitting...\$2.00 Female Fitting...\$2.20

Save—Order From This Ad from  
THE SMALL MAN'S TOOL HOUSE  
**T&T TOOL CO.**  
7663 GRAND RIVER AVE.  
DETROIT 4, MICHIGAN

# MAGNETS

ASSORTED MAGNETS with big list of handy uses.....\$ for \$1  
POWERFUL POCKET MAGNET ideal for testing metals.....\$1  
RETRIEVING MAGNET pulls tools, etc., from tank or lake.....\$3  
HOT PAD MAGNETS to insert in your own hot pads.....\$ for \$1  
SULLETIN BOARD MAGNETS to "pin-out" memos, etc.....\$ for \$1  
SLENDER MAGNETS remove chips from drill holes.....\$ for \$1  
WE REFUND EVERY PENNY IF NOT 100% PLEASSED... POSTPAID  
RONALD EYRICH, 1091 N. 48th St., MILWAUKEE 8, WIS.

GET THIS **Slip-on Coach**  
In KIT form and assemble yourself. Fits all makes of Pick-up Trucks, easy to slip-on or take off. Trailer Kits. Build-it-yourself blueprints for all types of house and camp trailers. Catalog 10c.  
**COMSTOCK TRAILERS, Dept. K, Parsons, Kansas**

DO HOURS of GARDENING  
WORK IN MINUTES WITH

**Ariens**  
*Yardster*  
ROTARY TILLER



Prepares seed bed  
without spading;  
cultivates all  
season long without  
hoeing! All steel  
hood provides  
complete side  
and top pro-  
tection!

The Ariens Yardster tills 12" wide, up to 6" deep. Non-winding, non-breakable steel "L" tines. Factory sealed lubrication; ball-bearing rotor. Complete hood protection. 2 h.p. engine. Two 10" cog-tire wheels; optional 2-speed wheel drive. It's America's handiest work-saver—priced amazingly low!

**ATTACHMENTS FOR ALL-YEAR USE**

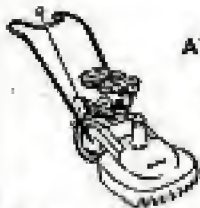

**ROTARY MOWERS**—Cut toughest weeds; mow finest lawns. Choice 20-inch or 16-inch sizes.

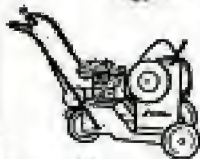

**POWER SPRAYER**—For field, garden, yard, orchard use. 5-gallon capacity. Mounted on all-purpose cart/cage.

**PLUS** rotary Sno-Thru, recoil starter, litter stirrer disc, paint sprayer, electric generator, all-purpose cart/cage.

Free! See your dealer or write for colorful folder and amazingly low prices.

*Ariens*

159 Calumet Street, Brillion, Wisconsin



**High Living for Mechanics**

Maintenance stands three stories high are used by mechanics servicing the Air Force's C-124 Globemasters. Tail sections of the planes are more than 48 feet high and require the special stands to reach every part. The big transports are moving supplies overseas and returning troops.

**Chemical Rust-Cutter**

In a matter of minutes an aerosol-spray chemical cuts through rust to loosen nuts, bolts and studs. Emitting a mist that penetrates the smallest crevice, the pressurized container makes it easy to apply the de-rusting chemical where it is needed. It also leaves a rustproofing surface film.



**LUBRIPLATE**  
KEEPS TOOLS LIKE NEW  
PREVENTS RUST  
AND LUBRICATES TOO!



**TRY LUBRIPLATE!** Not an old-fashioned oil that runs off or gets gummy. LUBRIPLATE is a new, white and clean, semi-fluid lubricant that stays put.

• In handy 20¢, 35¢ and 95¢ tubes at Sporting Goods, Hardware, Marine and Auto Supply Stores.

• Dealers write to LUBRIPLATE DIVISION, Fiske Bros. Refining Co., Newark 5, N.J.

**LUBRIPLATE**  
THE MODERN LUBRICANT

**LOW PRICED TURNTABLES**

for radios, TV converters, lazy susans, many other home, office, shop uses. Standard model's rigid 16 gauge steel plate, 12" x 8", rotates with 3/4" clearance on patented no-oil bearing, holds up to 50 lbs.



Agents, Dealers write for terms. Mfrs. write for other sizes.

Mail Check or M.O. to FURBLO CO., Hermansville 1, Mich.

Tune in the  
**AUTO-LITE**  
Show

**"Suspense!"**

CBS Radio Mondays  
CBS Television Tuesdays

**FREE CRAFT CATALOG**



**120 PAGES...** Craft Supplies, Tools, Designs, Instruction Books from America's Largest, Most Complete Handcraft Stock.

Send for your free copy NOW!

**GRIFFIN CRAFT SUPPLIES**

5626-A Telegraph Ave • Oakland 9, Calif.

**Say You Saw It in Popular Mechanics**

Protect your home against  
power interruptions  
with an...

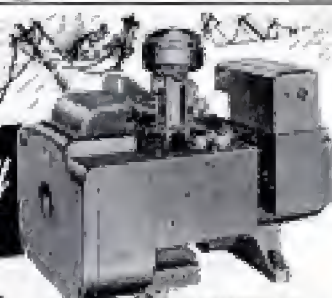

**ONAN Emergency**  
**ELECTRIC PLANT**

Provides dependable stand-by electricity for heating system, pumps, freezer, lights, appliances. Keeps home safe, livable. Automatic start and stop. Find out how little it costs!

Write for Folder!

**D. W. ONAN & SONS, INC.**

8574 University Ave. S. E.

Minneapolis 14, Minnesota

**A SIZE FOR EVERY NEED**  
1,000 to 50,000 watts.  
Compact, quiet-running,  
easy to install. Gasoline  
engine powered.

**FOR DOZENS OF HOBBY  
AND HOMECRAFT JOBS**

*plus all kinds  
of soldering*



- ♦ **INSTANT HEAT**  
saves time and current
- ♦ **DUAL HEAT**  
for heavy or light jobs
- ♦ **TWO SPOTLIGHTS**  
eliminate shadows
- ♦ **SPECIAL TIPS**  
for cutting, smoothing and soldering

Here's the fastest, most efficient soldering tool ever, and by simple interchange of tips it does dozens of other money-saving jobs. Thousands are in use by Radio and TV technicians and professional mechanics. 4 models up to 275 watts. See them at your Hardware Dealer, or write for catalog describing uses.



Cuts plastic tile



Seals freezer packages



Removes hard putty



Repairs furniture scratches

**Weller** **ELECTRIC GUNS**

816 Packer Street, Easton, Pa.

Available at Better Hardware Stores Everywhere

# TIME SAVING TIPS

ALL YOU NEED IS A TUBE OF

## DU PONT DUCO CEMENT

REG. U. S. PAT. OFF.

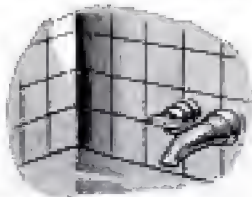

**LOOSE BATHROOM TILES** can be put back in to stay with tough "Duco" Cement. It's waterproof, too.



**DROPPED GLASSES** Save the day by anchoring lens or replacing chips with transparent "Duco" Cement.



**TRAIN IVY** on walls for distinctive decoration. Fasten string to wall with waterproof "Duco" Cement.



**UMBRELLA HANDLES** will come off . . . but they go back on to stay when fastened with strong "Duco" Cement.



**BUILD STRONGER MODELS.** Quick-drying "Duco" Cement is standard equipment with most model builders.



**BROKEN FINGERNAILS** get first aid with transparent "Duco" Cement to stop further damage.



**SCUFFED SHOES,** leather heels and inner soles can be repaired in a wink with Du Pont "Duco" Cement.



**CRACKED LENSES** on flashlights will hold fast until replaced, if they're mended with "Duco" Cement.



**DU PONT** BETTER THINGS FOR BETTER LIVING  
... THROUGH CHEMISTRY

(Continued from page 14)

it is impossible to guess where the half horn ring is located. By the time this half-ring section is located, it is too late to use it.

A horn signaling device is one of the most important safety helps on a modern car. It is of utmost importance that the control which operates or blows the horn is located in such a position that it is always in the same place. I cannot understand why a half or a whole horn ring was ever placed on a car because it is too close to itchy fingers who prefer to use the horn instead of their brakes and brains. Too many drivers seem to think that a little touch on the horn button leaves the responsibility of an accident entirely to the other fellow, so what chance does a pedestrian have? According to statistics, we kill and maim more people with our automobiles than in our wars. A horn is so small an item, but still it does so great a job if applied in the right way.

Could it be possible to have our automobile manufacturers abolish the horn-ring situation and make a useful horn button where it is available at all times?

William Bakker,  
Chicago.

### If You Drink, Don't Drive

And a Munich, Germany, inventor has a device to enforce that warning. Alfons Siedenhaus has built an alcohol meter attached by electric cord to the dashboard of his automobile. Before he can start the car, the driver must breathe into the meter. If the breath is too alcoholic, the car will not start; if only moderately tainted, the meter permits the driver to proceed at not more than 35 miles per hour.

★ ★ ★

Not many tourists have seen this road sign. It marks one of America's newest communities, a town being built some 400 miles north of Seven Islands on the St. Lawrence river, to house 500 men and their families. This is the "capital" of the new Ungava iron field, whose fabulous story is told in a feature beginning on page 118.



ENJOY BUILDING  
YOUR OWN

**RADIOS  
TRANSMITTERS • AMPLIFIERS  
TEST EQUIPMENT**

*Heathkit*

**COMMUNICATIONS  
RECEIVER KIT**



Build your own world-wide radio or choose from over 50 other top quality Heathkits. Easy to build from clear, step-by-step instructions. No specialized knowledge required. Low Kit prices include tubes and all necessary parts. Save money—buy directly from manufacturer.

MODEL AR-2  
**\$25.50**  
SHIP. WT. 12 LBS.

WRITE FOR CATALOG



**HEATH COMPANY** BENTON HARBOR 17,  
MICHIGAN

**MAK-A-LITE!**

**PERMANENT ASSEMBLY TO MAKE  
POWERFUL, PORTABLE LIGHT**

No moving parts; one minute to assemble. With screwdriver, hook up with 6-volt battery and a 95,000 c.p. light. Light draws 4% amp; battery lasts indefinitely. Assembly illustrated . . . . . \$1

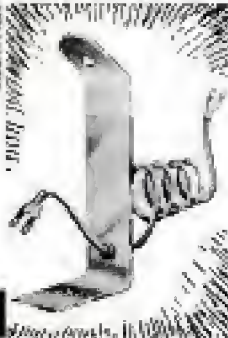

BARNES-DIVINE MFG. CO., INC.  
425 S.W. 24 Oklahoma City, Okla.



**SMALL! POWERFUL!**

America's finest low cost tractor. Ruggedly built. Easy to operate. No belts, no chains. Borg-Warner clutch, trans. and diff. 140 to 1 reduction. 25% more drawbar pull than ordinary tractors. 3-1/4 H.P. engine—gasoline or kerosene. 20 quick change implements.

Write for complete details.  
**ENGINEERING PRODUCTS CO.**  
915 N. 9 Niagara St.  
Waukesha, Wis.

**ARMSTRONG**

**Drop Forged "C"—CLAMPS**

Buy once, for life. These famous drop-forged, heat treated clamps will not creep, spring, spread or break. Screws have close fitting smooth operating threads. Available in heavy duty, medium service, extra deep throat and welding types. Recognized throughout industry as the very finest.

Write for catalog.

**ARMSTRONG BROS. TOOL CO.**  
"The Tool Holder People"  
5288 W. Armstrong Ave., Chicago 30, U.S.A.

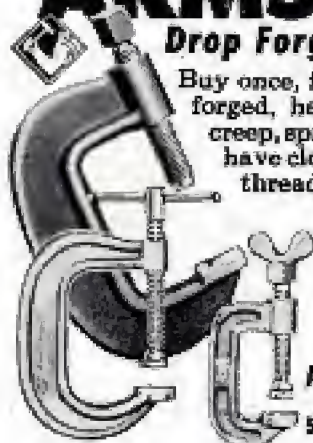

**for fast,  
clean boring**

*Greenlee 22*  
SOLID-CENTER AUGER BITS

Here's the auger bit that makes good workmanship come easy! Smooth, accurate holes are bored swiftly because solid-center design gives extra strength and provides fast, positive chip clearance. Every GREENLEE 22 Solid-Center Auger Bit has accurately sized, perfect cutting edges that last through long use. "Induction Heat Treated" for uniformity, long life . . . "Plastic Sealed" to reach you factory-sharp. Available in 18 sizes: from 4/16" diameter through 24/16". Buy singly or in sets attractively packaged in handy plastic rolls, steel boxes or metal holding panels. Stocked by leading hardware and building supply dealers.

**SPECIAL OFFER — GREENLEE  
WOODWORKING CALCULATOR—ONLY 25c**

Converts linear to board feet, gives nail specifications, tool sharpening tips. Compares woods, gives bit sizes for screws, concrete mixes, painting information, etc. Convenient . . . simple to read. 6" diameter circular shape . . . heavily varnished cardboard. Send 25c (no stamps please).



**GREENLEE TOOL CO.**  
2102 Columbia Ave., Rockford, Ill.

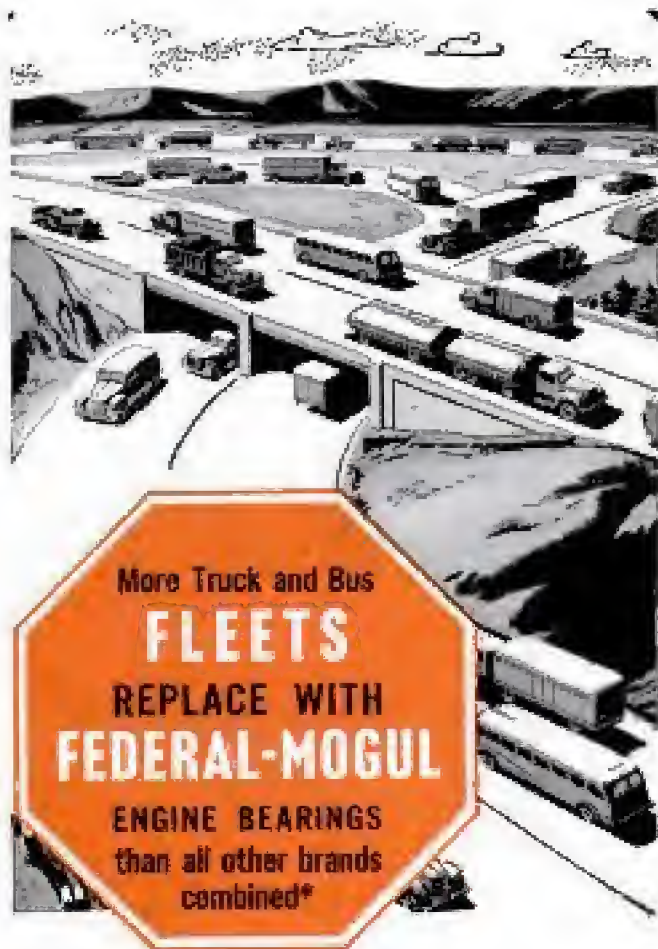

More Truck and Bus  
**FLEETS**  
 REPLACE WITH  
**FEDERAL-MOGUL**  
 ENGINE BEARINGS  
 than all other brands  
 combined\*

## To restore Full, Clean Power in Your Car

do as the Fleets do . . . replace  
 with Federal-Mogul Bearings

\*The men who run America's great truck and bus fleets know how to recondition engines for best results. In a recent survey of these experts, 53% of the replies stated that they used Federal-Mogul engine bearings in service work. Take advantage of the experts' experience! In reconditioning your car engine, restore full, clean power, pick-up and economy—install Federal-Mogul oil-control bearings! They cost no more, yet have been the best sellers in the replacement field for 30 years . . . because of quality! Federal-Mogul Service, Div. of Federal-Mogul Corp., Detroit 13, Michigan.

for New Power . . .

**FEDERAL-MOGUL**  
 Oil Control Bearings

BEARING  
 MANUFACTURERS  
 - TO THE  
 AUTOMOTIVE  
 INDUSTRY  
 SINCE 1899



## Parade of 1954 Cars

(Continued from page 154)

### THINGS to look for during 1954:

Buick, Oldsmobile and Cadillac advanced their 1955 plans up to 1954, bringing out costly new bodies, improved engines and other mechanical changes. Ford showed its new overhead-valve V8.

Transparent automobile roofs made their first production appearance in Mercury and Ford cars.

General Motors disclosed its experimental gas-turbine engine.

It is generally conceded that while 1954 will be a "good" sales year, it also will be competitive and even "rough."

There are distinct possibilities that the industry, or at least some of its members, will introduce 1955 models much earlier than in previous postwar years. Sales managers would like to get back to the fall introductions traditional in prewar years.

Engineers who are informed on such matters estimate that the new plastic Corvettes are costing as much as \$10,000 each to produce (they sell for about \$3500). However, production costs are expected to drop sharply after full output gets under way in St. Louis, where they will be mass-produced.

"The end of the lush market," a merchandising expert declared, "will come this year with the end of Cadillac's independence from depreciation schedules. Since the end of the war, Cadillac owners have been getting by on Chevrolet depreciation losses each year. But soon such owners will have to figure a depreciation of \$1500 or more on an annual trade in."

Sports cars are expected to become increasingly popular during 1954 with Dodge's "Firearrow" rumored as going into production. This will be somewhat different from the model unveiled at the Chrysler show, but with much the same body lines and power plant. Ford's sports-car entry should appear in 1954 also.

The V8 engine is a "comer" and while the only additional user in 1954 is the Buick Special, the rumors are that there will be a wholesale switch in 1955 and 1956. There are even rumors of midyear change-overs to V8. Mentioned in this category are Pontiac and Plymouth.

After that the only holdovers will be Chevrolet, Nash, Packard, Hudson and Kaiser-Willys and there are many indications that they will soon join the parade.

If there isn't a merger before summer among certain independents, you can expect to see a pooling of production facilities to save money in the competitive battle against the Big Three.



**GIGANTIC  
SAVE-TO-70%**

# MAIL SALE

**WAR SURPLUS  
EXCESS INVENTORY  
BANKRUPT STOCK**

## POWER PLANTS & GENERATORS

Note: all AC plants are 115-v 60-c.

- Plants 25 KW A-C.....\$1190
- Plants 15 KW A-C.....\$695
- Plants 3 KW A-C.....\$349
- Plants 2 KW A-C.....\$289
- Plants 1 KW A-C.....\$189
- Plants 3 KW 115-v D-C.....\$169
- Plants 1.5 KW 32-v D-C.....\$72
- Plants 1 KW 32-v D-C.....\$64
- Generator 3 KW 115-v A-C.....\$149
- Generator 2 KW 115-v A-C.....\$139
- Generator 1 KW 115-v A-C.....\$104
- Generator .6 KW 115-v A-C.....\$79
- Generator 3 KW 115-v D-C.....\$49

Save to 70% — See our catalog.

## WATER PUMPS & SYSTEMS

- Centrifugal 3/4".....\$19.95
- 1".....\$29.95; 1 1/2".....\$38.65
- Rotary. Bronze, rubber paddle. Self priming. Pressure in 30 lbs. 1 1/2".....\$14.75; 3/4".....\$18.89; 1".....\$28.
- Rotary. Bronze-steel roller. Self priming. Pressure to 100 lbs. 1 1/2".....\$17; 3/4".....\$24; 1".....\$32.
- Auto Water System. Lifts to 22 ft. 110-v 300 Gals. per hr. 40 lb. pres. Compact. Easy to install.....\$70

Gauges, valves, couplings, hose, etc. Closeout prices.

## SUPER CROCKET BARGAINS

- Famous make \$200 Tame Recorder \$149.00
- Winch, 1500-lb. cap. 1-4 ratio.....\$19.95
- Mechanics Tool Chest, 4-drawer.....\$19.75
- Gas Chain Saws, leading make.....\$139.00
- Electric Chain Saws.....\$89.25
- Rural Magneto Phones.....\$69.95
- Tarps, 10x12, 12x12, 12x16, 12x20, 20x30, 24x36.....\$21.95
- Revolver, Automatic, .38 cal.....\$39.99
- Electric Drill, 1/2" 110-v.....\$26.95
- Electric Drill, 3/4" 110-v.....\$18.89
- Drill Set, 20-Piece, 1/16" to 1/2".....\$8.99
- Air Corps 6-v Searchlight.....\$4.39
- Revolver, 6 shot 11 and 11 1/2" .22 c.....\$28.95
- City Wall Telephones.....\$4.99

Hundreds items, more lists than info. cost.

## BURDEN PAYS ALL SHIPPING CHARGES

## Watches—Optical—Precision Units

- Fully guaranteed 10-year top-quality leading makes—Save to 50%!
- Binoculars, 7x30 coated with case.....\$42.95
  - Microscope, 3-turret 100-200-300X.....\$9.95
  - Engineers Hand Level Army type.....\$2.19
  - Surveyors Tripod Level & Rod.....\$37.95
  - Weather Unit, barometer, hygrometer, thermometer.....\$12.50
  - Car Altimeter, 0-10,000' (Tagdon).....\$9.00
  - Wrist Watch, 17-jewel, "Executive" Gem-Union Engrs. Specify man's or lady's.....\$18.15
  - Knobs, Stop Watch, precision 1/10 sec.....\$12.95
  - Inspection Magnifier, 2"x4" lens.....\$2.80
  - Deluxe Auto Compass, 11mm. type.....\$5.40
  - Hand Tally Register, records 0000.....\$4.95
  - Drawing Set, 11-sheet 13-1/2" in case.....\$9.78

## HYDRAULIC EQUIPMENT

- Savings to 80%. Bulk loaders, diggers, presses, etc. Marvaco values.
- Pump, 1000 lb. 12 gal. 500 RPM.....\$49.50
  - Cylinders, 1-way 3"x8".....\$11.95; 2-way 2" x10".....\$22.89; 2-way 3"x24".....\$39.00
  - Valves, hand control, 1 or 2-way.....\$18.00
  - Gauges, 1400 psi., 1500 lb. or 3000-lb.....\$3.49

Many other items—see our catalog.

## AIR COMPRESSOR UNITS

- Paint, clean, for tires, control terminals, etc. Build your own or ready built units.
- Deluxe Kit, Tank, compressor, gauges, valves, paint gun, regulator, fittings, etc. "How To Build" instructions.....\$70 value.....\$45
  - Economy Kit, same, smaller tank, no regulator.....\$32
  - Components, Compressors, 220. Tanks \$5.78. Auto Press, Switch \$4.95. 1000 lbs. \$1.89. Pop-Off Valve \$1.95. Paint Gun \$2.95. Dust Gun \$1.29.

Many air tools, see catalog.

## SPECIAL For The Month!

### Precision Binoculars 8x25

- Powerful, 8x25 coated achromatic lenses and prisms. Old world precision craftsmanship. Ship. Crystal clear. Guaranteed. Equipment to 87.5 planes.
- Complete with attractive case, leather carrying straps, etc. Tax paid \$26.78 Ppd.

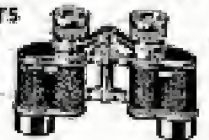

### TRACTOR WEED SPRAY OUTFITS

- Finest stainless steel 20' Trow boom, tractor pump, push button control, hose, gauge, etc. Only 41 available. List \$225. Ppd. \$129.50



Save 50% on spray eqpt. Write for spray catalog.

### GENERATOR—3000W—115V

- Dir. Current ball brg. compound-wound Delco unit. 1" dia. shaft, 3800 RPM. Ideal for portable tools, lights, hoists, etc. Guar. List over \$100. Prepaid.....\$49.50



### GOVT. AIR TANK UNIT

- Large 10"x18" 400 lb. test tank with gauge, hose, air chuck, liquid nozzle, etc.
- PSI tires, blow dirt, spray yard. Cost \$90. \$14.95 Ppd.



### ARMY PARTS CLEANER

- Amazing air-solvent cleaner. Makes dirty Army parts shiny bright in secs. For garages, factories, farms, etc.
- Heavy galv. tank 35x30x20". Air jet valve, hose, hyd. lid raiser. Cost over \$100. Ppd. \$29.95.



ORDER FROM AD or write for big FREE CATALOG 1000s of items! Motors, sporting goods, hand and electric tools, clothes, clothing, watches, toys, winches, etc. Write for your copy of Free Catalog — today!

### FARM-CONTRACTOR LEVEL

- Precision unit. Complete with tool tripod. For terracing, ditching, foundations. \$70 value. \$37.95 Ppd.



### AIR CORPS SEARCH LIGHT

- 11" Intensity 6-v mirror beam. With case, colored filter. Cost over \$20. \$4.39 Ppd.



### CITY EXT. TELEPHONE

- Standard wall phone used on city systems. Many uses. Such as extension, inter-comm., etc. Cost over \$27. Sale \$4.99 Ppd.



OUR 30-YEAR POLICY • EVERYTHING GUARANTEED TO SATISFY • WE PAY ALL SHIPPING CHARGES IN U. S.

**BURDEN SALES COMPANY**  
816 "O" ST. LINCOLN, NEBRASKA

WELD

BRAZE

SOLDER

CUT

**4WAY**  
ONLY \$14.75  
f.a.b. factory

**WELDER**  
Complete with Twin Carbon Arc Torch and accessories... to handle all metal-craft work.

Acclaimed by thousands of Homeowners, Mechanics and Hobbyists as the welder of 1001 uses. Easily operated from properly wired 115 volt AC or DC line. The ideal gift with a life-long use....Order today on 10 day money back guarantee.

**FOUR-WAY WELDER CO., Dept. F2-B**  
2326 S. Michigan Ave. • Chicago 16, Ill.

## EVER GLASTING

FIBERGLAS BOAT ARMOR

### FOR ALL BOATS

New easy method designed for simple application. New laminator X-97 (pat. pend.) needs no experience. It's safe! Assures perfect job first time. X-97 is ready mixed! Requires no curing or sunlight. Can be used in normal temperatures. Has unlimited shelf life. Applied in morning, ready for use same day. X-97 available in colors, also clear, which can be painted. Apply glass cloth yourself! Make hulls watertight. Permanently stop leaks on decks & roofs. Keep new boats new longer, used boats in use longer. Save money on upkeep and repair bills.

**TRY IT! CONVINCCE YOURSELF!**

Send \$5 for complete repair kit postpaid (refundable on first order) or 10¢ for illus. booklet.

**EVER GLASTING** • DEVELOPED BY U-MAK-IT PRODUCTS  
709B— WHITTIER ST., Bronx 59, New York City

## FILE SAWS FOR PROFIT!

- BeMaCo Rapid Saw Filer
- **MAKES SAW FILING EASY.** Opens the door to extra profits. A power driven filer that takes the work out of saw filing. Anyone can operate it. Gives full control to the operator. Priced Right. Write for literature today!
- BeMaCo Automatic Saw Set — Uniformly sets 400 teeth per minute on hand or band saws. Perfect hammer and anvil action. Acclaimed by saw shops across the country.

**START EARNING TODAY!**

- **BEAVER MFG. CO.**
- Saw Machine Div. B-C
- 300 S. ISIS AVE. • INGLEWOOD, CALIF.

## REMOVE RUST EASILY

from chrome and other metals



**METAL TREAT** is also an excellent rust preventive and metal pre-primer

Just rub on concentrated Metal Treat and unsightly, damaging rust comes right off automobile chrome, tools, outdoor furniture, machinery and other metal surfaces. And, before you paint any metal surface, prime it with diluted Metal Treat to prevent rust and make paint stick (12 oz. bottle makes full gallon). Metal Treat is sold by most paint and hardware stores.



### METAL TREAT

Another quality product of  
**THE KLEAN-STRIP CO., INC.**  
2364 S. Lauderdale, Memphis 6, Tenn.

## BOAT KIT BUILDERS!

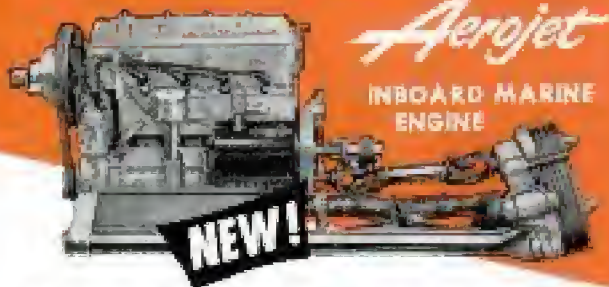

**Aerojet**  
INBOARD MARINE  
ENGINE

**NEW!**

4 cycle—26½ h. p. motor and Vee-drive. Weighs only 220 lbs. drives 12-20 ft. boats ½ m. p. h. to 30 m. p. h. Cuts fuel costs 50% compared to outboards of comparable H. P.

- Vee-drive reverse and reduction drive
- 9 to 1 compression
- 24¾" L x 17½" W x 19½" H.
- Overhead camshaft
- Overhead valves
- 4 hours to install

**\$695<sup>00</sup>**

State and  
Federal  
Taxes  
extra

WRITE FOR FREE BOOKLET

**AEROJET-GENERAL CORPORATION • Cincinnati 14, Ohio**

Gentlemen: Send me information on new Aerojet Inboard marine motor, and name of your nearest dealer.

NAME \_\_\_\_\_

ADDRESS \_\_\_\_\_

CITY \_\_\_\_\_ STATE \_\_\_\_\_ 6

**AEROJET-GENERAL CORPORATION • Cincinnati 14, Ohio**



### Aluminum Inside Storm Sash

Casement windows can be weather-proofed by a new type aluminum storm sash that attaches to the inside of the frame. Each panel is held by clips screwed into the holes which already exist in all casement frames. A vinyl plastic weatherstrip gasket forms an airtight seal between the window and the frame. Ventilation is provided by a special panel that is suspended from the top of the primary frame by two attachments while the lower edge acts as a hinge. Interior aluminum screens can also be attached in the same fashion.

### Trigger Lock

Firearms can't be discharged until a new trigger lock is removed. The lock fastens securely over the trigger guard with a key and can't be removed without using the same key again, thereby preventing children from accidentally or intentionally pulling the trigger. The lock will fit any standard revolver, pistol, rifle or shotgun.



If you have  
a hammer



You'll do a more professional job with Plastic Wood. Fills nail holes, covers hammer marks. Handles like putty, hardens into real wood.

You need "PLASTIC WOOD"

Stronger—resists weather—  
sands to a smooth finish.



**NEW HULL AUTO COMPASSES  
ARE EASIEST TO INSTALL**

• Greater accuracy and a patented, more positive means of compensating against magnetic interference have long kept Hull Auto Compasses first with America's motorists. Now, choice of a new vacuum cup mounting bracket with special adhesive, or the original clamp type, gives greater-than-ever ease of installation.

Write for local dealer's name, free literature



Beaconite 1/8 in.  
SPECIALTY 1/4 in.

**HULL MFG. CO.** P.O. Box 246, D1  
WARREN, OHIO

**SILVER SOLDER TORCH & KIT \$7.95**

JOINS ALL METALS PERMANENTLY  
Do your own repairing. KIT includes one tube silver solder (paste and 10 dots), lengths silver solder pipe, Hottest ALUMINUM TORCH known. 2700° F. flame. Operates in any position, indoors or out. Tank of special fuel included. Complete outfit ready for use \$7.95 postpaid. TORCH alone with pipe of special fuel \$4.95. KIT alone \$1.05. Instructions included.

AMERICAN PRODUCTS CORP., 422 S. Dearborn, Dept. 3-B, Chicago



**DR. GRABOW PIPES**



BECAUSE THEY'RE  
**PRE-SMOKED**

\$7.50  
TO  
\$5.00

GARDENING SHOULD BE

*Fun*

NOT DRUDGERY

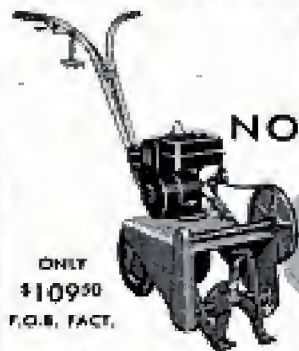

SELF-PROPELLED  
**TERRO  
TILLER**

ONLY  
\$109.90  
F.O.B. FACT.

Dept. B WRITE FOR ILLUSTRATED BROCHURE  
COMMUNITY INDUSTRIES ASSN. • SULLIVAN, ILL.

**FREE GOLD BOND  
ROCK WOOL  
INSULATION BOOK!**

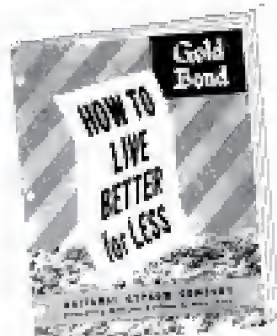

Your key to a  
**\$25-\$100**  
yearly saving

• Mail the coupon right away for the big, fact-packed Gold Bond Rock Wool Insulation Booklet... absolutely free! Tells you how Gold Bond Rock Wool Insulation can slash your present heating bills as much as 25%—save you \$25-\$100 every year! Shows you where and how to insulate to keep your house warmer in winter, cooler in summer. Tells you how Gold Bond Rock Wool Insulation quiets your rooms and gives you fire protection! Mail coupon now!



Tells how to install Gold Bond Rock Wool Blankets between joists of unhoored attic.



Shows how to apply rugged Gold Bond Rock Wool Blankets between rafters of floored attic.



If room already built, shows how easy to insulate with Gold Bond Rock Wool Blankets.



In attic with joists not of standard spacing, shows how to use Gold Bond Pouring Wool.

**SEND FOR FREE BOOKLET TODAY!**

**NATIONAL GYPSUM COMPANY**  
Dept. PM-24, Buffalo 2, N. Y.

- Send me, absolutely free, your 24-page booklet on Gold Bond Rock Wool Insulation.
- Send me the name of my nearest Gold Bond Dealer.

Name \_\_\_\_\_

Address \_\_\_\_\_

City \_\_\_\_\_ Zone \_\_\_\_\_ County \_\_\_\_\_ State \_\_\_\_\_



*car stall?*

**get  
instant starts**

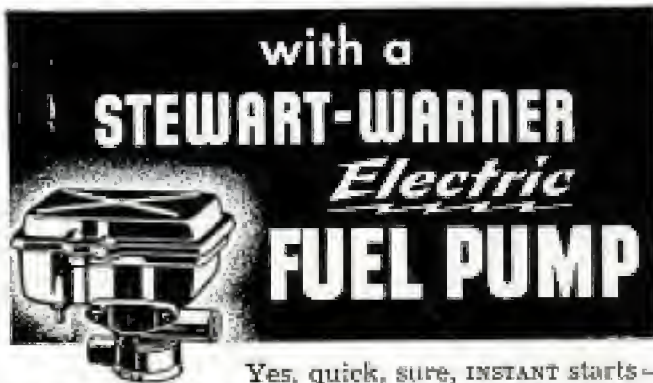

with a  
**STEWART-WARNER**  
*Electric*  
**FUEL PUMP**

Yes, quick, sure, **INSTANT** starts—every time—in any weather. No more stalling! This Stewart-Warner Electric Fuel Pump delivers all the gas your engine can use the second you turn on the ignition. Operates independently of the engine. Saves your battery. Easy to install on any car or truck.

**STEWART-WARNER**

Instrument Division, Dept. N-24  
1840 Diversey Parkway, Chicago 14, Ill.

**CORBIN PADLOCK**  
withstands burglars'  
.45 cal. bullets!

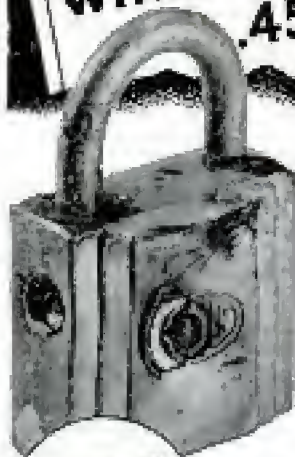

Here's proof that **CORBIN** padlocks are the safest, strongest you can buy!

Mr. Robert M. Chester, 10721 Tabor St., Los Angeles, Cal., writes:

"Burglars placed two .45 cal. bullets into my Corbin padlock at vital points to force it open—without success! My congratulations to you on the production of such high quality in a popular priced article."

**INEXPENSIVE  
—BUT WHAT  
A BUY!**

When **YOU** want to be sure . . . safe . . . really secure, insist on a **CORBIN** padlock.

55c up at better hardware stores everywhere.

**CORBIN CABINET LOCK** Division

The American Hardware Corporation  
New Britain, Connecticut, U.S.A.



### Portable Heater Matches Warmth From Furnace

Furnishing as much warmth as the average furnace, a new portable gasoline or oil heater is the size of an orange crate and weighs only 114 pounds. Its one motor, which can be run from any 110 volt AC or 24 volt DC source, operates a blower that provides both ventilating and combustion air. The blower delivers maximum heat through long runs of ducts or hoses without the aid of additional fans or blowers. A glow plug vaporizes and ignites the fuel and a single operating switch provides manual control of high or low-speed operation. The heater holds enough fuel for five hours of high speed service. Although primarily intended for industrial stand-by, emergency or area use, the unit can provide central heating for homes with little or no basement space. When not permanently installed it can be moved about to heat "cold spots" developing because of a change in the wind direction or the weather.

### Custom-Made Insecticides

Insecticides custom-made to kill certain insects, yet harmless to other forms of life, are reported to be more effective than DDT. Developed at the University of California, the hydrocarbon chemicals combine with enzymes in the insect's body to stop their action. Different chemicals are needed for different insects. One is 100 times as deadly as DDT for the flour beetle—another equals DDT in destroying mosquito larvae but is harmless to other species.

## DO MORE PLANING JOBS WITH LOW COST BELSAW

Exclusive MONEY-MAKING features:

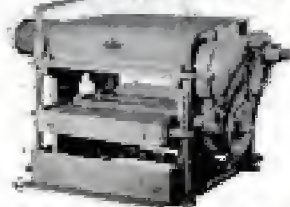

- Full 12 1/4 in. x 6 in. capacity
- Power feeds at 24 ft. a minute. (Easily adjusted for lower feed rate)
- Machined cast iron bed; adjustable rolls, total bed length 42 in.
- Provides for Grinding Knives in the Cutterhead.
- Attachments for Jointing, Rabbeting, Tongue, Groove, Matching.

Belsaw Multi-Duty Planer for cabinet shops, builders, lumber yards, woodworking plants and spare time work shops... Now you can convert low cost rough and random size lumber into high priced cabinet finished stock... Easy to make flooring and popular patterns. Belsaw quickly returns cost with savings on raw material... profits on finished stock.

Send Today for FREE literature on Belsaw, the LOW COST, high speed production planer.

**BELSAW MACHINERY CO**

1010 Field Bldg. • Kansas City 11, Missouri

LOW DOWN  
PAYMENT  
EASY  
TERMS

## More people use

For more than 50 years 3-IN-ONE has been America's most popular household oil. If it works better with oil, it will work best with 3-IN-ONE.



## "3-IN-ONE" OIL

### GERMAN STEEL HIGH TEMPERED TWIST DRILLS — Set of 9—90c

Quality made by German Craftsmen of finest tool steel. For electric or hand drill 1/16-3/4" ingenious plastic combination case & stand for safe storage — easy handling. 3 for \$2.50; 6 for \$4.90. Add 10c for postage & handling.

**STANDARD SALES CO.**

Dept. PMD, Box 18, Bowling Green Station, New York 4, New York

### "SHOOPER" GEIGER COUNTER

Super-sensitive! Only 1 1/2 lbs! Fits pocket—uses flashlight battery. Find a fortune in uranium. Order Now! Send \$5.00, balance C.O.D. MONEY BACK GUARANTEE. FREE CATALOG—stimulator and larger uranium and metal detectors. DEALERS WANTED.

**2995** **PRECISION RADIATION INSTRUMENTS**  
2235 PM S. LA BREA, LOS ANGELES 16, CALIF.

## SAVE HUNDREDS OF DOLLARS with HOME-A-MINUTE "KIT"



Design and build your New Home, Attic Flat, Extra Bedrooms or Remodeling—IN MINUTES—with over 100 transparent plastic partitions, Doors, Windows, Kitchen Cabinets, made to scale same as blueprints. Then, believe it or not, you, the layman, who knows nothing about building, can estimate your own costs—IN

MINUTES—after you adjust charts to local prices. Don't build anything until you get this "KIT". If you want to save money, Handbook tells you how. This information should not pass you by. Complete "KIT" \$9.95 ppd., or C.O.D. plus postage. \$1 deposit required on C.O.D. orders. Handbook without "KIT" \$2.95 or free literature. Money back guarantee. Return in 10 days. Dealer inquiries invited.

**R. J. HALL & CO.** 3824 W. ROOSEVELT DR. MILWAUKEE 16, WIS.

## WOODCRAFTSMEN'S

## ENCYCLOPEDIA

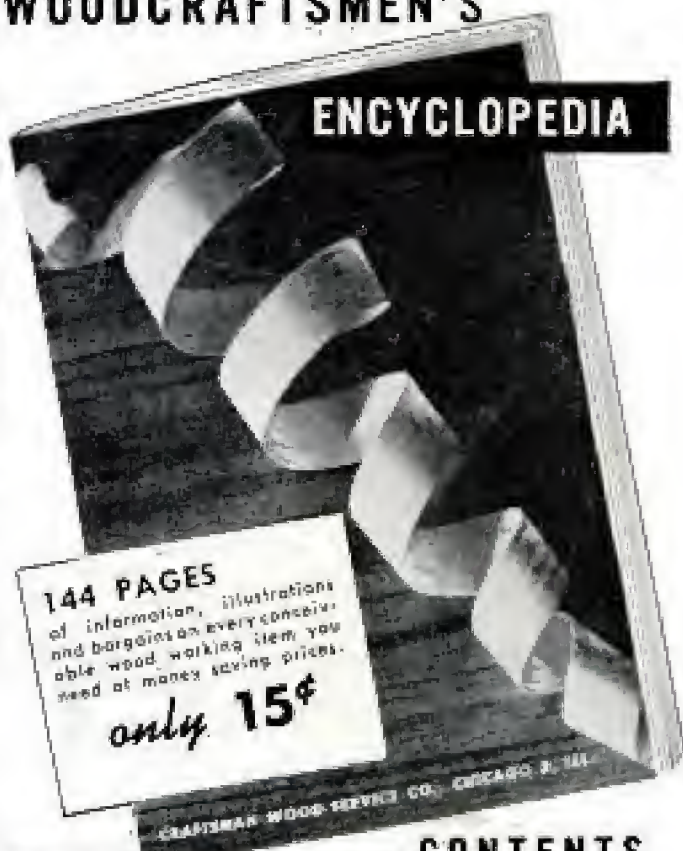

144 PAGES of information, illustrations and bargains on every conceivable wood working item you need at money saving prices.

only 15¢

CRAFTSMAN WOOD SERVICE CO. CHICAGO 8, ILL.

### CONTENTS

Rare and fancy woods, domestic and imported woods, panels, matched plywoods, veneers, multicolored inlay bandings, beautiful natural color inlays and overlays. Embossed mouldings, carved ornaments, hundreds of scroll saw patterns, woodworking tools and equipment, cabinet hardware and fittings, more than 1500 items, HOW-TO-DO IT information, projects and ideas. Send for your copy today, the biggest 15c worth ever offered.

MAIL THIS COUPON

**CRAFTSMAN WOOD SERVICE CO.**

Dept. A-2 • 2729 S. Mary St. • Chicago 8, Ill.

Gentlemen: Enclosed find 15c. Please send me your big book No. 20.

NAME \_\_\_\_\_

ADDRESS \_\_\_\_\_

CITY \_\_\_\_\_ STATE \_\_\_\_\_

TODAY

**Non-Blister ~~Hand~~ Handle**  
**Speeds Your**

**P & C**  
**Screwdriver**



Fluted amber plastic, shaped to fit your hand. Won't shock, burn, chip or mushroom. Acid, grease-proof. Polished alloy steel bit scientifically heat treated, hardened and tempered. Every P & C tool is guaranteed — "the best tool money can buy". Ask for the P & C screwdriver at your dealer's.

**P & C HAND FORGED**  
**TOOL COMPANY**

Dept. H-254, Box 5926  
 Portland 22, Oregon

Buy it from this P & C Display in your favorite tool store. TODAY—Send 10c for P & C's big catalog. Over 500 tools fully described.



### Radiation Locket

Some sailors in the United States Navy will soon add an atomic-radiation locket to their dog tags. The plastic pendant contains a phosphate-glass detector sensitive to radiation. When it is inserted in a small computer-indicator it activates a meter telling how much the wearer has absorbed.

### Radioactive Safety-Control System

Radioactive crystals and Geiger tubes make a punch press at a United Air Lines maintenance base accidentproof. Operators of the press wear wristbands containing the "hot" crystals. Three Geiger tubes enclose the punching area. If hands stray into danger, the tubes pick up radiation from the wristbands and instantly halt the machine—even in midstroke. The machine will not run unless the operator wears the bands.

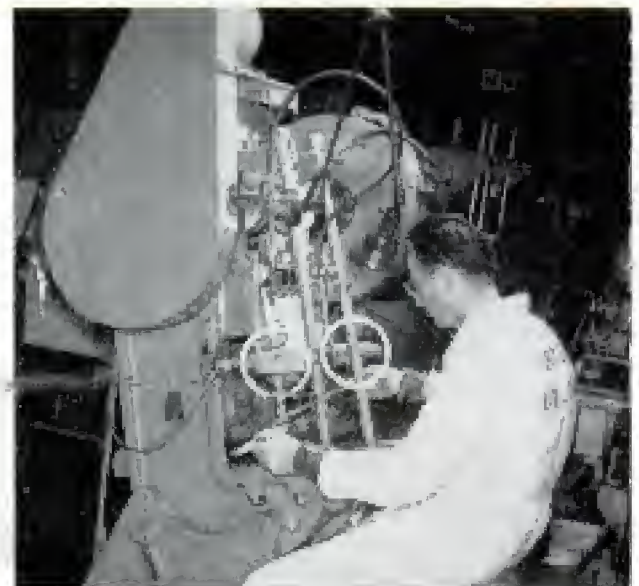

**Can You Equal This Home for 3128**

Shipped  
 Direct  
 from Our  
 Mill



*Save 30% to 40%  
 on Your New Home..*

Don't pay several hundred dollars more than necessary when you build a home! Buy direct from our mill at our low factory freight-paid price. We ship you the lumber cut-to-fit, ready to erect. Paint, glass, hardware, nails, etc., all included in the price — no extra charges. Plans furnished — also complete building instructions. No wonder our customers write us that we saved them 30% to 40%. Architecturally approved construction. (Not prefabricated.)

**BIG BOOK**  
 of  
 House Plans  
 in Colors  
 25¢

### Handsome Big CATALOGUE

Pictures wonderful homes in colors at money-saving prices. Designs to suit everyone. Send 25c for catalogue today.

**LEWIS MANUFACTURING CO.**  
 1242 LAFAYETTE AVE. BAY CITY, MICH.



## Stutz SAFETY STABILIZER

STOP SKIDS ON ICE, SNOW, WET OR DRY SURFACES!

Easy to install — Fits all cars!

If you drive a car, here's a safety device you can't afford to be without! It's the Stutz Stabilizer . . . a gyrostatic balance control unit developed by a sports car-racer to offset skidding, swaying, vibration on any road surface . . . icy, snowy, wet or dry! Tested on the track in actual races . . . used by state and local police. Just bolt to chassis. Order today! Satisfaction guaranteed! \$34.50 prepaid. Check or Money Order, no C.O.D.'s. Dealerships available.

### STUTZ STABILIZER COMPANY

Dept. M, Boston Post Road, Orange, Conn.



### NEW! EXCITING! JET EXHAUST CUT-OUT

Now your car can sound off those exciting, dynamic tones — easily controlled mechanically from your dashboard. Channel your exhaust through special pipes or muffler without removing your original muffler. Easily installed. **MONKEY BACK GUARANTEE.**

- MADE OF HEAVY PLATE STEEL
- UNIVERSAL—FITS ALL EXHAUSTS

Send \$1.95 (prepaid) check, cash, money order (add \$1.00 for postage outside of U.S.A.) to:  
Fur Sales, Dept. PM2, 1840 S. Michigan Ave., Chicago 16, Ill.

Dealer inquiries invited

## BOAT KITS

Models from  
39.25 complete

19 Ft.  
Runabout

- Assemble your own boat
- No experience necessary
- Save 1/3 to 2/3 "factory built" prices
- Prices include freight and paint



Marine Hardware & complete accessories.

Free Catalog of all models

## LUGER INDUSTRIES

Kit Division 3207 FREMONT AVE. SO. MINNEAPOLIS 8, MINN.

### MACHINE SHOP EQUIPMENT

The NEW edition of the famous Center Tool Co. Catalog is now ready! Every workshop owner should have a copy. 240 pages full of illustrations, descriptions, and prices of the latest tools made by best known manufacturers in U.S. You pay the cost of printing — \$1.00. We refund your \$1.00 with first order of \$25.00 or more. Prompt delivery on most tools. Send check or money order today!

CENTER TOOL CO.

152 Centre St., Dept. C, New York 13

## DON'T BE CAUGHT WITH A DEAD BATTERY



Amazing "New Life" battery rejuvenator stops build-up of plate sulfates . . . keeps battery automatically charged. Use lights, heater, radio, as much as you like! Get faster starting! Greater power! **RECHARGING IS UNNECESSARY!** Only one treatment needed! Money back guarantee. Rush \$1.00 to:

JSM PRODUCTS CO. • 1118-D Castleton Rd., Cleveland 21, OHIO

## SAW TREES FAST!



Saw down trees. Cut to lengths. — Cut fence posts. Clear land. Saw cordwood quick, easy. Hide while you work. Get facts on this Amazing Tractor Saw. Write for **FREE FOLDER, LOW PRICES!**

SUNFLOWER MFG. CO., OLATHE, KANS.

PATENTED  
SUNFLOWER ROTO SAW

# FREE PLAN

Tells How to Start  
Your Own Business

## FILING SAWS

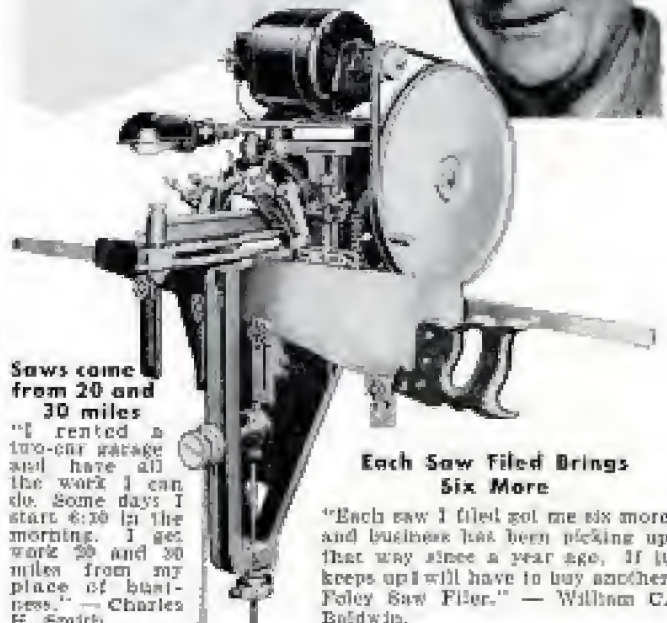

Saws come from 20 and 30 miles

"I rented a two-car garage and have all the work I can do. Some days I start 6:30 in the morning. I get work 20 and 30 miles from my place of business." — Charles E. Smith.

Each Saw Filed Brings  
Six More

"Each saw I filed got me six more and business has been picking up that way since a year ago. If it keeps up I will have to buy another Foley Saw Filer." — William C. Baldwin.

### FOLEY FILED SAWS BRING NEW CUSTOMERS

Here is a steady repeat CASH business you can start in your own basement or garage in your spare time. Every saw you sharpen with the machine accuracy of the Foley Saw Filer is an ad that brings you more customers. E. M. Hollingshead wrote to us: "I am doing very well with my Foley Filer, and I am glad I invested in your machinery. It is very satisfactory and works very well in the small community in which I live."

You can file all hand saws, also band and cross-cut circular saws on the Foley Saw Filer. The adjustments are simple — there is no eyestrain — and you can start right away to turn out perfect cutting saws. "The first saw I sharpened with my Foley Filer came out 100%. I think it is a marvel of perfection." — writes Clarence E. Parsons.

### FREE BOOK Shows How To Start in Spare Time

#### "MONEY MAKING FACTS"

explains how you can set business from hardware stores, home owners, farmers, carpenters, schools, mills, factories, etc. Just think — with a modest investment, no overhead, no stock of goods to carry, you can start right in on a cash business that will help pay the rent, buy groceries, or a new car. Start now — send coupon today. No salesman will call.



Send for **FREE BOOK**

FOLEY MFG. CO., 216-4 Foley Bldg.  
Minneapolis 18, Minn.

Send me free book "MONEY MAKING FACTS."

Name \_\_\_\_\_

Address \_\_\_\_\_



Ductile cast iron twists without breaking. Behind vise is machined casting. Multiple-exposure photos show ordinary cast-iron and ductile-iron trivets being dropped on marble slab. First one shatters. Second one is intact

## Ductile Cast Iron Combines Advantages of Iron and Steel

Cast iron that bends instead of breaks results from alloying cast iron with small amounts of magnesium which control the size of graphite particles in the casting. Low in cost, the new ductile metal is used where the strength and toughness of steel and the complex casting ability and machinability of cast iron are desired. Ductile cast iron corrodes less than does steel and resists

heat better than ordinary cast iron. Crankshafts for diesels, automotive pistons and clutch plates, jet-engine support rings, and many applications in heavy industry are among its uses. In a recent demonstration, a strip of the ductile cast iron was twisted nearly two full turns without cracking. Other tests illustrated the machinability and toughness of the new metal.

# It's easy to make these REPAIRS

You can make loose metal, wood, or plastic parts tight; anchor bolts in concrete to stay; seal cracks in metal; tighten loose screws and fixtures in wood, metal or tile—with Smooth-On No. 1, the iron cement of many uses. Just mix, and fix. Smooth-On No. 1 hardens quickly like iron, and expands as it sets. Forced into any opening, its unique expanding action makes the repair. Keep a can on hand, it will not deteriorate. Smooth-On No. 1 is at your hardware store.

## FREE Repair Handbook

40 pages, many illustrations, easy directions for ingenious time and money saving repairs you can make yourself. Write for your free copy.

SMOOTH-ON MFG. CO., Dept. 37C  
570 Communipaw Ave., Jersey City 4, N. J., U.S.A.

# SMOOTH-ON

THE IRON CEMENT OF MANY USES

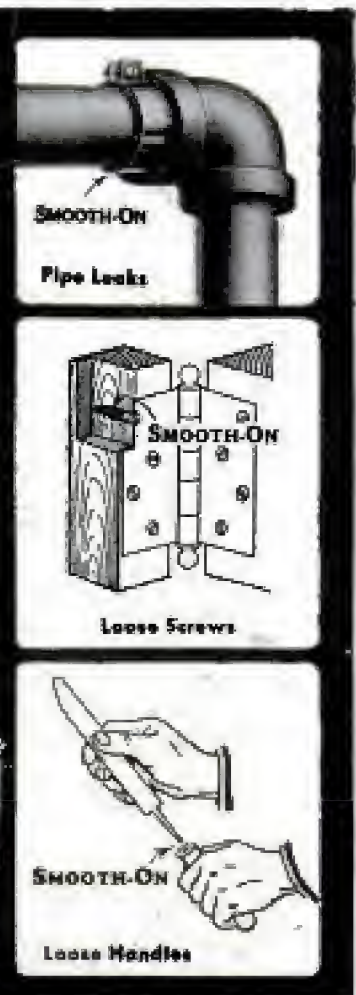



**DOES EVERYTHING A PIPE-  
WRENCH WILL DO, AND MORE!**

**THE AMAZING  
RATCHETING CHAIN  
WRENCH**



Takes the place of 4 pipe wrenches. Gets into tight places where a pipe wrench cannot be used... capacity  $\frac{3}{8}$ " to  $4\frac{1}{2}$ ". For jobs around the home, garage or service station.

A must for farmers, steam-fitters, plumbers, electricians.

Grips anything round or hex, in corners or up against a wall.

**AT HARDWARE, PLUMBING, AND AUTO SUPPLY DEALERS OR WRITE DEPT. P. M.**

**Owatonna Tool Co., Owatonna, Minnesota**



**ONE-MAN SAWMILL LOW \$50.00 DOWN AS...**

Take BELSAW Portable Sawmill right to the trees — turn out valuable lumber for home and farm — sell to local yards — make up to \$50 a day custom sawing for neighbors. BELSAW lasts a lifetime. No crew needed. Power with tractor or auto engine. Beginners get excellent results. Send today for FREE BOOK, "HOW TO MAKE LUMBER".

**BELSAW MACHINERY CO**  
8118 Field Bldg., Kansas City 12, Missouri

**FREE BOOK**

**"HYDRAULICS PLANS 10¢"**

LEJAY's 10¢ plans show how to build loader, hoist, dozers, etc. We have necessary hydraulic parts. Included FREE: are welder plan and electrical catalog listing hundreds of bargains in war surplus, "assemble-your-own welder kits" and "build-yourself" hydraulic kit. **SEND DIME TODAY** for both PLANS and catalog.

**LEJAY MFG. CO., 1547 LeJay Bldg., Minneapolis, Minnesota**

**AUTO DEALERS  
TOY STORES  
WRITE US  
FOR DEALER  
PRICES  
ON YOUR  
LETTER-  
HEAD**

**ESHELMAN 70 MILES PER GAL. GAS  
CHILD'S AUTO WITH MOTOR**

Sturdy, Safe for kids 5 to 10 years. Also pulls Mowers, Cars and Power Tractors, Lawns, Pumps, Saws, etc. Write for literature.

**ESHELMAN, Dept. CM-82, 140 Light St., Balto. 2, Md.**  
333 N. Michigan Ave., Chicago 4, Ill.  
7070 H'wood Blvd., Los Angeles 28, Cal.

**2 H.P.**



**SLIDE RULES**

**Guaranteed Accurate Slide Rules Regularly Sell for \$4.00 and Up**

World's most useful tool for fast, easy calculating. Multiplying, proportions, division, roots. Full 10-inch A, B, C, D, CI, and K Scales. "Clearsite" hair-line indicator with metal frame. Ideal for

- Bookkeepers
- Salesmen
- Farmers
- Mechanics
- Students
- Draftsmen
- Housewives
- Armed Forces
- Everyone



**FREE** Complete Instructions on how to get correct answers instantly without pencil or paper

**98¢** postpaid

**SLIDE RULE MAN, Dept. 102-A**  
2031 Shore Blvd., Astoria, L. I., N. Y.

**8-INCH TILT ARBOR SAW \$19.95**

**Save \$20.05**



\$21.95 West of Mississippi

Extensions, guard, blade extra

**PRECISION GROUND CAST IRON TABLE**

Miter Gauge and rip fence included — standard equipment.

- Rips, Miters, Bevels, Dadoes, Miter Mouldings.
- Patented blade tilt mechanism and patented ball bearing motor mount.
- BIG CAPACITY — CUTS 2 x 4's AT 45°
- TIME PAY PLAN

Write for FREE information

**15 DAY FREE TRIAL**

**POWER TOOLS INC.**

101 Yates Ave. Beloit, Wisconsin

**"THE NAME THAT MADE BOAT KITS FAMOUS"**

**U-MAK-IT BOAT KITS**

**MOST COMPLETE LINE**  
8 TO 23 FEET

**PRAMS—ROWBOATS—OUTBOARDS**



**18 FT.—21 FT.—23 FT. Outboard & Inboard Cabin Cruisers**

**BIG ILLUS. CATALOG**

44 PAGES, shows construction details for everything to build your own — hardware, engines, conversions, paint & color chart. Also Fiberglass covering for all Kit Boats, ideal for Cabin Roofs.



**SEND 35¢ COIN TODAY**

**U-MAK-IT PRODUCTS**

703P—WHITTIER ST., Bronx 59, N. Y. City

## Atkins Silver Steel Pruning Saws

for quick and easy pruning of small limbs and branches.

## Atkins Silver Steel Hand Saws

Get a 12 point saw for fine finishing. Picks up where power tools stop.

*For Hobby or Profit*

## Use ATKINS, the Experts' Choice!

Whatever you need in saws, there's an Atkins *Silver Steel* for the job! Yes, Atkins complete line offers exactly the correct choice for the hobbyist, the home craftsman and the professional carpenter. Nearly 100 years experience goes into Atkins production of the right saw for every cutting job. Ask for Atkins at hardware stores and building supply dealers—you'll get the saw you want at the price you want to pay!

THE CHAMFER

*New Atkins*

## Chamfer Chain!

U.S. PATENT NOS. 2,326,854 & 2,632,636

The greatest saw chain development ever! And—"It's The Chamfer That Does It"—an Atkins exclusive. Cuts smooth, fast and straight—stays sharp much longer. Get Atkins Chamfer Saw Chain for the easiest cutting you've ever known—available now for every make of chain saw.



# ATKINS



ATKINS SAW DIVISION, BORG-WARNER CORPORATION  
INDIANAPOLIS 9, INDIANA



## Canvas Car Basket

All the odds and ends which don't seem to fit into a suitcase are contained in a light-weight canvas basket with a steel-rod frame. The big basket has a leather-bound rim, two reinforced canvas handles and a wood-runner base. Made to fit into the trunk of an automobile, it can also be shipped by mail or express. Various sizes are manufactured.

## Basement Drain Sealer

Basement drains fitted with a new sealing disk are closed against sewage backflow, sewer gas, vermin and bugs. The bottom ring of the two-piece unit is cemented into a standard drain after the perforated cover has been removed. The actual closing disk screws down onto the ring, its rubber facing forming an airtight seal when the drain is closed. When drainage is desired, the lid is unscrewed a few turns or removed.



## LASTING PROTECTION



### GUARANTEED NOT TO CRACK, CHIP OR PEEL!

"How it lasted!" say boat owners who use BoatLIFE Durable Plastic Finish. Beautiful glossy BoatLIFE, tested for years under the most severe weather and water conditions has been found to be the toughest, most flexible, finest finish your boat can have. BoatLIFE is WATERPROOF, unimpairedly flexible and elastic. Resistant to marine growth . . . protects against rot.

So Easy To Apply! Flows on smoothly, even over other finishes. Dries tack free in damp weather. Use on wood, metal or canvas. On metal, use primer first. BoatLIFE outlasts and is superior to the finest spar varnish!

Whether you choose glistening Plastigloss, or any of BoatLIFE's brilliant colors, Blue, Red, Green, Gray, Black, Ivory, and new yellowing Flat or Gloss White, you'll be delighted with its smooth glossy surface. Ask for BoatLIFE at your dealer. Or order direct. THINNER FREE with each can. \$3.85 qt., \$12.80 gal., postpaid. West of Mississippi add 25¢ qt. or 90¢ gal., to cover shipping costs.

WRITE TODAY FOR FREE FOLDER WITH COLOR SAMPLES

Boat Builders! Send 10¢ for folder "How to Select the Right Boat Lumber." Helpful for construction and repairs.

M. L. CONDON CO., INC. (Est. 1912)

(Specialists in Marine Finishes and Boat Lumber)

266 Ferris Avenue

White Plains, N. Y.

**Motor coupling included**

**DRAINS** cellars, laundry tubs;  
**FILLS** tanks; **CIRCULATES**  
**oil**; **IRRIGATES** gardens, fields.

Original "Type 1" All-Purpose Pump has 2400 GPH capacity, 1000 GPH 7 1/2" high, or 1500 GPH from 25" well. Use one 1/4 to 1/2 HP motor. **DOES NOT CLOG!** 1" intake, 3/4" outlet. Only \$6.95 postpaid if cash with order. West of Miss. add 50¢ MONEY BACK GUARANTEE.

Also Gear Pumps in all sizes.

**LABAWCO PUMPS \$6.95**  
BELLE MEAD 2, N. J.

**YOUR TICKET TO THE ATOMIC ERA**

Write today for FREE valuable literature from the world's leading supplier of Strategic Metal & Mineral Detectors. RADIAC's descriptive literature will open up a new profitable field for all Treasure-Hunters and Prospectors. There are Geiger-Counters, Scintillation Counters, D.V. Lights, Electronic Mineral Detectors & Big Sirens for URANIUM, GIL & STRONTIUM MINERAL PROSPECTING. Electronic Metal Detectors for finding Buried Treasure and locating, tracing buried pipes, cables, etc. These winners of modern electronics may mean a fortune to you.

RADIAC CO., Inc., 489 Fifth Ave., Dept. PM-2, New York 17, N.Y.

### SAY YOU SAW IT IN POPULAR MECHANICS

**MORE JOBS EASIER QUICKER**

With Gear-Driven "RED-E" GARDEN TRACTORS

**NO BELTS! NO CHAINS!**

Proven For Over 30 Years

**NEW 1954 MODELS**

Thousands of satisfied users say "RED-E" has solved their tractor problems. You, too, will like its smooth, powerful, easy-to-operate, gear-driven action—with power twisting clutch for 4 1/2 and 6 H.P. WALKING MODELS and automotive type differential for 3 1/2 H.P. RIDING MODEL. Our 2 and 3 H.P. Walking Models low as \$169.00. Attachments for plowing, sowing, cultivating, wood-sawing, snow-plowing, etc.

**EASY TERMS—Factory-To-You discount. Write for FREE Catalog.**

**RED-E TRACTOR CO., Richfield 470, Wisconsin**

Buy Direct from Manufacturer and SAVE

WRITE FOR FREE CATALOG

# TIPS for the HANDYMAN

## ON USING L-O-F SUPER-FINE FIBER-GLASS

Here's a new insulating product of "1001 uses." Wonderfully easy to handle and apply. And so versatile, so effective, you'll find uses for it in a dozen places 'round the house.

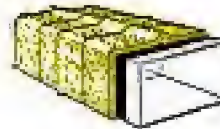

Save fuel by wrapping fire-resistant Super-Fine around your heating ducts! Highly efficient heat insulation. Flexible, lightweight, easy to install.



Reduce dripping from cold water pipes. Reduce heat loss from hot water pipes. Spiral wrap them with Super-Fine. Will not mildew or rot.

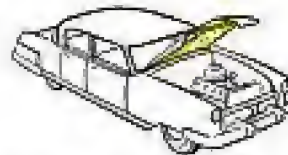

L-O-F Super-Fine installed under the hood of your car reduces airborne noise, tire whine and air-stream whistles.



Sound-insulate your home workshop! L-O-F Super-Fine provides excellent sound absorption. Cuts easily with scissors or knife.



Get L-O-F Super-Fine at your favorite hardware dealer's, where this rack is on display. If your dealer doesn't have it, write Libbey-Owens-Ford, Fiber-Glass Division, 4824 Wayne Building, Toledo 3, Ohio.



## FIBER-GLASS

Send For Your Copy of the  
**FREE** NEW 1954 4-Color  
**CATALOG** of  
**MIDWEST**  
**TELEVISION** and **RADIO**  
 Receivers Featuring **BIG 21"** and **27"**  
 TV Consoles, Table Models and  
**Complete CHASSIS**

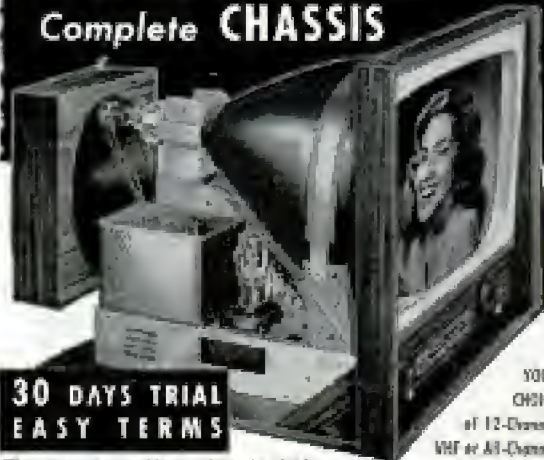

**30 DAYS TRIAL  
 EASY TERMS**

The most magnificent line in Midwest's 34 years of radio and television manufacturing. Your choice of genuine Mahogany veneer, Walnut finish, or Blond Lined Oak cabinets. **FACTORY-TO-YOU.**

YOUR  
 CHOICE  
 of 12-Channel  
 VHF or All-Channel  
 VHF-UMF Models

**MIDWEST** World-  
 Ranging **RADIOS**



SEND THIS COUPON ON 3¢ POST CARD FOR NEW 1954 FREE 4-COLOR MIDWEST CATALOG

**MIDWEST RADIO & TELEVISION CORP.**  
 Dept. K-25, 909 Broadway, Cincinnati 7, Ohio

NAME \_\_\_\_\_  
 ADDRESS \_\_\_\_\_  
 CITY \_\_\_\_\_ ZONE \_\_\_\_\_ STATE \_\_\_\_\_

## HELPFUL BOOKS

Send post card asking for **FREE** catalog  
 Popular Mechanics Press, 200 E. Ontario, Dept. 801, Chicago 11

TRIPLE ELECTRODE

### LUTHY AERO SPARK PLUGS

with ALUMINUM OXIDE INSULATORS  
 Just what your car needs—for extra "zip and go" and lasting power. **THREE TIMES LONGER LIFE.**

Give better performance and last longer because of these features:

- **3 POINT ELECTRODES.** Tapered points for hotter spark and 3 times longer life.
- **"LUM-OX" INSULATORS.** Used exclusively in the LUTHY AERO SPARK PLUG. First used in combat aircraft during World War II. Keep plugs cool by fast thermal conduction. Highly resistant to mechanical shock, too.
- **CHROME PLATED.** For resistance to rust.
- **NO GAP SETTING NECESSARY.** Every set perfectly engineered for your make and model at the factory.



Pat. App. For

SET \$5.34  
 GP \$7.12  
 Postpaid

**LUTHY AERONAUTICAL SALES COMPANY**  
 3023 COOPER ST., JACKSON, MICH.  
 CANADIAN ADDRESS: BOX 394, HAMILTON, ONTARIO

Send me a set of \_\_\_\_\_ plugs. Enclosed is \$ \_\_\_\_\_  
 Check here for C.O.D.

Name \_\_\_\_\_  
 Address \_\_\_\_\_  
 Year of car \_\_\_\_\_ Make and Model \_\_\_\_\_



### Flashbulb Belt

Flashbulbs are carried conveniently in a plastic belt that is hung around the neck or across the chest. Both hands are left free for picture taking and bulbs are quickly removed and loaded into the flashgun for multiple shots. The spacing of the bulbs keeps them from rubbing against each other and breaking.

### Bicycle Shock Absorber

Cobblestones and bumpy roads don't bother French cyclist Jean Arhan since he installed a "cushioned ride" in his bike. The bicycle seat is mounted on a rod attached at the bottom to the frame. A spring enclosed in an aluminum tube holds the rod in position and absorbs road shocks. It also brings the seat forward to help support the rider when he is pedaling hard.



**75 YEARS MAKING GLUE**

**LEPAGE'S STILL THE BEST!**



**LEPAGE'S INC. GLOUCESTER, MASS.**

**STICK WITH LEPAGE'S**

Guaranteed by Good Housekeeping

**Durra-James POWER TOOLS**

*Better Than Ever!*

WRITE for CATALOGS

**TOOLKRAFT CORP., SPRINGFIELD 1, MASS.**



**ELECTRIC WELDER** AC or DC 110 Volts

The "Little Marvel" all-metal welder. 5-year written guarantee. Welds 1/4" metal or money back. Repairs tanks, tools, fenders, machine parts, etc. Complete with everything—rods, unit, eye shield, directions.

\$8.45 plus 50c postage. Flame torch accessory for soldering, cutting, brazing \$3.95 complete with carbons, brass rods, flux. Sorry no C.O.D. Buy direct and save.

**ESSAY MFG. CO., Dept. 51, Quincy 49, Mass.**

**\$6.45** Complete



**CRESCENT TOOLS**

*Give Wings to Work*

ASK YOUR HARDWARE DEALER

**SURPLUS SALE!**

**ROTARY FILES**

MADE OF HARDENED HIGH SPEED STEEL

Regular price \$13.45. For plaster, magnesium, steel, brass and aluminum working. Guaranteed. (All other sizes available.) Order by check, money order or C.O.D.

**PULASKI METAL PRODUCTS CO., INC.** Pulaski, N.Y.

**\$5.00 for all 6**

Sizes 1/4, 3/8, 1/2, 5/16 and 3/16. All 1/4 inch shank.



**GLASS FIBER PAD FILTERS FURNACE AIR!**

Trap grime, grease, dust with economical disposable 1" thick Glasfloss filter pads! Long glass fibers catch grease vapors from cooking, too, and purifies air. FITS ALL TYPES GRILLE REGISTERS. Save house-cleaning time, money, temper. Install it yourself. Simply remove grille, cut pad to size, place under register. Replace as needed. Carton of 10 sq. ft.; enough for several registers. \$2.50

Postpaid. No C.O.D. Satisfaction Guaranteed.

**ELRON 219 W. Chicago Ave., Dept. 950, Chicago 10, Ill.**



**CUT FUEL BILLS**

**UP TO 40%** with

**TORIDHEET'S**

*Direct Heating Action*



Unlike conventional heating units TORIDHEET'S flames actually contact the walls of the combustion chamber, communicating their tremendous heat directly to the surfaces which heat the water or air.

This direct heating action insures the maximum efficiency from your fuel. Think what this means to you—in dollars and cents.

**COMPARATIVE EFFICIENCY TABLES**

Conventional Coal Furnace	Oil in Ordinary Burner	Oil in Toridheet Burner
Heat	Heat	Heat
Wasted Gases	Wasted Gases	
Soot and Carbon	Carbon	
Ashes and Clinders		Wasted Gases

Complete furnaces or conversion burners—oil or gas.

**For Fuel Savings up to 40%**

**MAIL THIS COUPON TODAY!**

**TORIDHEET DIVISION**  
Cleveland Steel Products Corporation  
7312 Madison Avenue • Cleveland 2, Ohio

Please send me complete facts on the TORIDHEET Wall Flame burner with direct heating action.

Name \_\_\_\_\_

Address \_\_\_\_\_

City \_\_\_\_\_ Zone \_\_\_\_\_ State \_\_\_\_\_

**YOU CAN START A**

**\$40 A DAY  
BUSINESS  
IN YOUR SPARE TIME**



Andy Phillips says: "MyBELSAW Sharp Smith gives me big profits at low expense — I can run 35 to 40 circular saws in an 8-hour day — that makes me \$40 cash."

"I also get BIG EXTRA PROFITS... up to \$4 an hour... by grinding planer and jointer knives — there's always a demand for this kind of work."

You can start this REPEAT CASH business in your own home or garage while you are working at your regular job. Easy to operate, no experience needed. "Pays for itself from just 65 jobs." — *Harvey Jensen*

For as little as \$15 down payment, you can get your BELSAW SHARP SMITH rushed to you.

**FREE book tells how**

YOU can start making money the very day your BELSAW SHARP SMITH arrives. Earns \$4 to \$5 an hour in your SPARE TIME sharpening and setting circular saws for builders, lumber yards, factories... Plus BIG EXTRA CASH, precision grinding planer and jointer knives, plane irons, wood chisels and drill bits. Hundreds of jobs in your own neighborhood. No extra equipment needed, no canvassing. Send today for your Free copy of "Life-Time Security."



**BELSAW MACHINERY CO**

3705 Field Building

Kansas City 2, Mo.

**PRINT postcards like MAGIC**

**5 in up to  
COLORS  
AT ONCE**



without  
inks  
or  
stencils

Yes it's true! With the new Post Master Spirit Postcard Printer, you can reproduce anything, you can write, type, or draw in up to 5 colors — at a small fraction of normal printing costs!

It's fast, it's clean and so easy to use. Prints with Spirit Solution from carbon masters. Uses no messy inks or stencils — Prints with no waste — you get bright, clear copies every time. Ideal for postcard advertising, church or club mailings, printing labels, tags, and many other uses.

Order yours today from your office supply dealer. If he can't supply you, we'll ship direct on a money-back guarantee.

**Master Addresser  
COMPANY**

6500-P West Lake Street  
Minneapolis 16, Minnesota

**\$11.95**

INCLUDING  
MASTER UNITS, COLORED  
CARBONS, FLUID AND  
STORAGE CASE

\$12.95  
West of  
Denver, Colo.

**PLYMOUTH  
SAVE  
MONEY!** Owners



Learn How to Make Your  
Car Run Better . . . Last  
Longer . . . and Save Hundreds of Dollars!

Get this book, written especially for you, without one penny of risk and get more out of your car. Mail coupon for MANUAL FOR PLYMOUTH OWNERS today. When the book comes, skip through the pages and see how your investment in one of America's most popular automobiles can be even a better investment than you thought. If you don't agree, send the book back and you'll get your money back.

**A Popular Mechanics  
Book Written Just for You**

Not a re-hash of service manuals. A complete new Popular Mechanics book written for the Plymouth owner by an outstanding automotive authority with the full cooperation of Plymouth engineers and service directors. It will save you money on repairs and service; make your Plymouth last longer; give you safe, economical and trouble-free motoring. And this is true whether you take your Plymouth to a regular service station or service it at home.

**Prevents Trouble. Cuts  
Down on Repair Bills**

Nothing like this manual anywhere. It covers all phases of operation, service and maintenance. It has entire chapters on the individual parts of your Plymouth — battery, ignition, starter, generator, regulator, lighting, fuel system, engine, lubrication, gasoline quantities, cooling systems, transmission, differential, rear axle, brakes, wheel alignment, tire care, body maintenance, trouble shooting on the road, etc. It covers your Plymouth, new and older models, step by step — bumper to bumper — showing you how parts operate; what can go wrong; how repairs and adjustments should be made and how to avoid all types of troubles.

**Money Back  
if Not Satisfied**

Mail the coupon today. Send only \$3.50 or you can pay postman. Money back guarantee protects you.

**Official, Authoritative,  
Practical Information**

Written by C. E. Pacher, formerly service school instructor and auto show lecturer for automobile manufacturers, Member Society of Automotive Engineers, Special Services Editor of Automobile Digest, contributor to leading magazines, author of some of the biggest selling books on Automotive subjects. Prepared with the full authority and active cooperation of the Plymouth Division of the Chrysler Corporation.

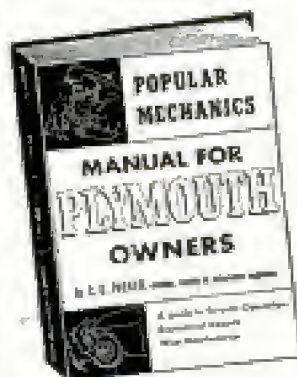

**288 Pages. Hundreds of How-  
To-Do-It Illustrations and  
Diagrams**

The entire book follows Popular Mechanics famous easy-to-read and easy-to-understand style. While primarily intended for the Plymouth owner, to help him get more out of his car at lower cost, it can be worth its weight in gold to the auto mechanic and service station operator who works not only on Plymouths, but on all other makes as well, to which the information in the book can be easily applied.

**Order on this Handy Coupon**

**POPULAR MECHANICS PRESS**  
200 E. Ontario St., Chicago 11, Ill.

Send Manual for Plymouth Owners at once. If not satisfactory I will return it within 5 days and you will refund full purchase price.

Remittance for \$3.50 enclosed.  Send C.O.D.

Name \_\_\_\_\_

Address \_\_\_\_\_

City \_\_\_\_\_ State \_\_\_\_\_

POPULAR MECHANICS

Copyrighted material

**Get Our Big Manual of  
"HARD-TO-GET" ITEMS**

For home craftsmen, wood workers, industrial art departments, furniture repair men, hobbyists, cabinet makers, etc.

A few of the items we sell include, fancy cabinet wood, lumber, Masonry, Bells, Dimension cut lumber,ignum Vitræ, Carving Blocks, Turning Squares, 124 kinds of screws, Abrasive papers, archery bows, ball-bearing chains, brass pins, bed fasteners, Dampriana, Chair bruce, brass chain, brass ferrule, Craftman blocks, candle stick holders, candlestick sockets, card table hardware, casters, Chair cane, ceramic tiles, clamp balls, crib hardware, Dovels and dowel pins, dovetail centers, drawer cutlers, felt, Flock finishes, foam rubber, furniture clamps, complete professional finishing materials, Fobbing tablelegs, hand tools, furniture pulls, modern and period, chest and ornamental hardware, all types of hinges and locks, small box hardware, inside picture kits, inside card table tops, leather working tools, Micarta, revolving Laser Saws, musical instruments, musical wood carvings, Metalcraft material, Moto Sander, nut bowl hardware, Picture frame moldings, Pre Cut Wood Plx, perforated steel panels, plaster standards, plastic and plexiglass, internal curved bits, plastic polishing compounds, Electric routers, sanders, tool sockets, hand drills, grinders, revolving fixtures for television tubes, chairs, etc. Fibre rust, screw hole buttons, spiral saw blades, shiling shoe track, sharpening stones, home owners specialties, 100 woods, oil woods, platform rocker springs, Table leaf supports, tack bags, upholstered cards, turned furniture legs, wood chisel fixtures, Complete upholstery supplies, Vacuum presses, wood turning pens, wood working instructions, black and copper wrought iron hardware, zipper wire.

Send fifty cents today (included on 1st order) for your copy of the Country's leading Catalog, "Constantine Manual for Craftsmen" to

**ALBERT CONSTANTINE & SON, Inc.**  
Dept. PM-20 797 East 135th St. New York 56, New York

**PLYWOOD BOAT KITS**

(Freight Included) 12 FT. \$9700  
14 FT. \$12900



Build these 12 or 14-ft. sport runabouts from readycut parts. Kits include all hardware, etc., to complete the boat shown. Send for free folders of all models as low as \$32.00 freight included.

**TAFT MARINE WOODCRAFT**  
Dept. J, 638 39th Ave., N. E., Minneapolis 21, Minn.

**SURPLUS SALE**

**\$39.50** NEW TOOL POST GRINDERS  
REGULAR PRICE \$125.00

1-1/2 H. P. MOTOR  
13000 RPM UP TO 1/2" x 1/4"  
CERAMIC WHEEL EXTENSION OR  
INTERNAL \$49.50  
MORSE RACE GUARANTEE

Less Grinding Wheel

**EDWARD J. NOLAN, POLASKI, NEW YORK**

**VARIABLE SPEED** HYDRAULIC POWER TRANSMISSION



It has infinite speeds 0 to 500. Reversible, Automatic Overload Protection, Adjustable Torque up to 150 inch pounds, 3/4" Input and Output Shafts. It will handle 1/2 to 1 1/2 H.P. Motor. Case measures 7 1/2" long, 7" high, 6 1/2" wide, VALUE OVER \$200. Shipping Wt. 22#. On C.O.D. Orders we require a 10% only. **\$54.50**

Dept. Chicago

**DURZIUS MACHINE SHOP "K" 1423-75 So. 52nd Ave., Cicero 50, Ill.**

**TOOLS AT FACTORY PRICES**  
Save up to half on Fully Guaranteed New Tools

6 pt. 12 pt.

6-PIECE DEEP SOCKET SET  
1/2" Drive, 8 pt. at 12 pt. Deep 1/2" **\$4.00**  
Be sure to specify whether you want 6 pt. or 12 pt.

**MATCHED SETS**

1/2" Drive: 12 sockets, 3/16" to 3/4"; 4-handle, flex-handle, 7 extensions, steel box **\$ 5.00**

1/2" Drive: 8 sockets, 1/4" to 1/2"; reversible ratchet, flex-handle, speeder, universal joint, 4 extensions, steel box **\$12.00**

3/4" Drive: 12 sockets, 1/4" to 1 1/2"; reversible ratchet, flex-handle, speeder, universal joint, extension, steel box **\$15.00**

3/4" Drive: 16 sockets, 1/4" to 3"; reversible ratchet, flex-handle, 7-bar, 2 extensions, steel box **\$40.00**

See page catalog free with order; or send 10c for catalog only. Send money order, check or currency to

**MECHANICS TOOL CLUB 5319 HORTON STREET OAKLAND 8, CALIF.**

**ONLY 7" SAW  
to rip 8 feet  
in 7 1/2 seconds!**

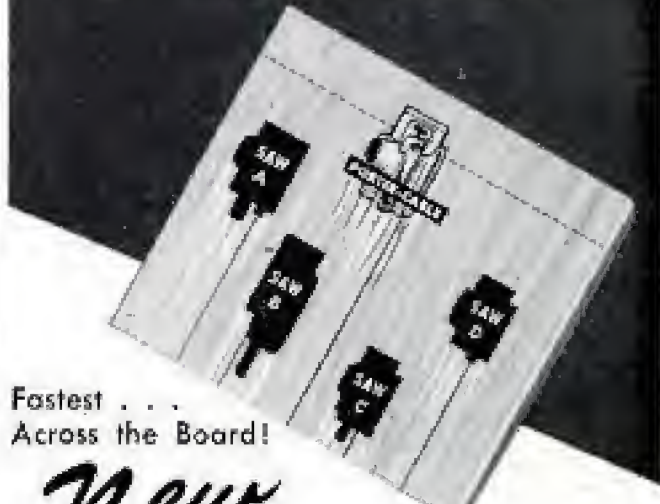

**Fastest . . .  
Across the Board!**

**New  
Porter-Cable 7" Saw**

In a recent series of on-the-site ripping tests comparing leading 7-inch saws, Porter-Cable's new "Contractor's Special" turned in this amazing speed record:

18.6% faster than Saw A      51.6% faster than Saw C  
41.7% faster than Saw B      38.7% faster than Saw D

Regardless of the depth of cut or type of wood used, the new "Contractor's Special" in every instance finished the cut for faster than any of the other saws tested! For example, on 3/4" Fir Plywood, the "Contractor's Special" averaged 7.5 seconds per 8-foot cut!

**"The Contractor's Special"**

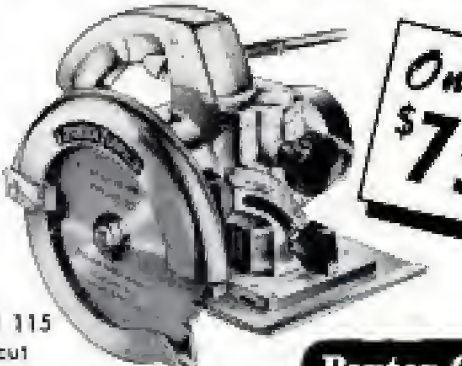

**Only \$75.**

Model 115  
2 3/8" cut

**Porter-Cable**  
Quality Electric Tools

See this remarkable new 7" saw at your Porter-Cable Dealer's. Or mail coupon for full details.

**PORTER-CABLE Machine Co.,**  
2642 N. Salina St., Syracuse 8, N. Y.  
(In Canada, send to: Strongbridge, Ltd., London, Ont.)

Please send complete information on your new Model 115 Saw . . . also name of nearest dealer.

Name . . . . .

Address . . . . .

City . . . . . County . . . . . State . . . . .

Manufacturers of SPEEDMATIC and GUILD Electric Tools

# WISE-GRIP HELD OUR CAR TOGETHER FOR 400 MILES ON THE ALCAN HIGHWAY!



"On the 2,000 mile return drive from Alaska to the U.S., a main lead on our front spring broke . . . left us stranded 400 miles from civilization! I clamped the springs together with my Vise-Grip. It HELD — over 400 miles of washboard roads to the next garage. Hats off to Vise-Grip!" — Mr. C. E.



# WISE-GRIP WRENCH

DOES MORE JOBS EASIER THAN ANY OTHER TOOL!

True stories like this show why Vise-Grip is the **HANDIEST** tool of all! A squeeze of the hand locks these powerful jaws onto work with **Ton-Grip**. Pulls, bends, turns, twists, ratchets, cuts — **WON'T SLIP**. A whole tool kit in one trim tool! At your dealer.

7-W, 7" \$2.75  
10-W, 10" \$2.60

Made only by PETERSEN MFG. CO., DEPT. M-2, DE WITT, NEBR.

## TV PICTURE INTERFERENCE

"Vid-tropic" TV WAVE TRAP stops PICTURE interference instantly. No more annoying wavy lines, jumping pictures, streaks, etc. caused by autos, appliances, power lines. Easy! Attaches to set in 30 seconds.

# STOP INSTANTLY

## RADIO and TV NOISES

New electronic design "Bell-tropic" line filter eliminates NOISES caused by all motors, appliances, autos, air burners, etc. Simply plug radio or TV cord into filter & filter into wall socket.

**\$298**

Add 35c P.P. & Imp.

**TUBE WHOLESALERS CO.**  
BOX 364, DEPT. PMA  
ROCKVILLE CENTRE, N. Y.

**\$100**

Add 25c P.P. & Imp.



No C.O.D. — Try 5 Days Money Back Guarantee  
**SPECIAL OFFER \$400** For Both  
Don't Accept Inferior Imitations

Make Money SELLING Eshelman Tractors and doing GARDEN WORK

KARL PLOWS CULTIVATES HARROWS HAULS SPRAYS SAWS DOZER MOWS CUTS ROLLS TILLS SNOW FLOW

## ESHELMAN

FOR BETTER LAWNS and GARDENS

1 1/2 H.P.

Also Power Mowers, Lawnmowers, etc.

ESHELMAN, Dept. 52  
119 Light St.,  
Baltimore, Md.  
333 N. Michigan Ave.,  
Chicago 1, Ill.  
7020 Hollywood Blvd.,  
Los Angeles 28, Calif.

## Find HIDDEN TREASURES



GEIGER COUNTERS (as shown) for Uranium Detection. TREASURE DETECTORS for gold, silver, etc. Lightweight, ultra sensitive. Best at any price. Also mineralights.

**INFORMATION FREE**  
Detectron Co.  
5420 Vineland, North Hollywood, Calif.

# CUTS ALL WITH SAME BLADE

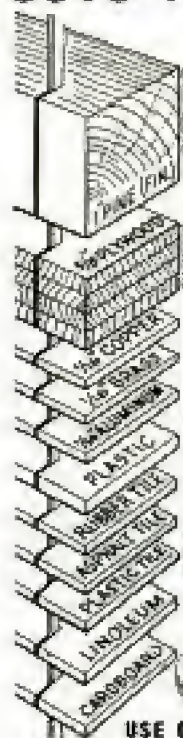

The amazing Synco Magnetic Jig Saw cuts all the different materials pictured with the same blade so smoothly no sanding is needed and without "splintering." 15" throat clearance. Adjustable arm takes any length cut. Quiet. Portable. Safe for children! Built-in reciprocating electric motor guaranteed against burn out. Used in schools, homes. 60 Cycle, 110-120 Volt AC. Only \$24.95 at dealers or post-paid. Free Circular.

**MOST POWERFUL SAW OF ITS KIND!**

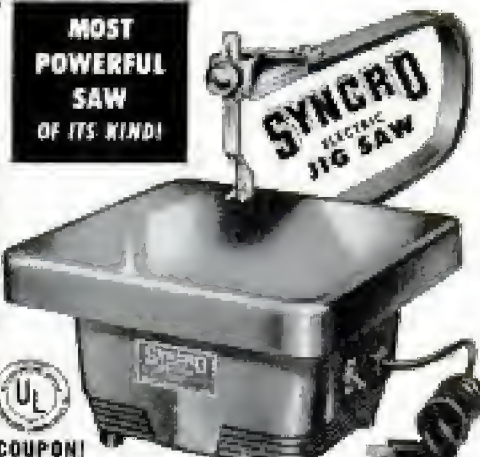

USE COUPON!

SYNCO CORP., DEPT. D-24, OXFORD-MICHIGAN, U.S.A.

- ORDER. 1 enclosed \$24.95. Send No. 201 Saw postpaid on 16 day money back trial. Built-in Motor included in price.
- FREE SAW & BANDER CIRCULARS.

(WRITE NAME, ADDRESS IN WHITE SPACE BELOW!)

# OWN A... FORD?

## FIX IT YOURSELF!

Popular Mechanics Magazine has just published a new Owners Manual covering all 1941 to 1952 models of Ford cars . . . So accurate mechanics use it . . . so simple a woman can understand it.



Save money on your Ford car repairs. Prevent trouble. Enjoy care-free driving. Increase trade-in value. Avoid major repairs by fixing minor troubles before they get serious. Get sparkling performance at all times. Has 232 pages, more than 300 photos, diagrams, tables, charts, breakdown drawings, plus clear, non-technical directions that make all repairs simple as A B C. Written by Ed Packer with the assistance of the Ford Motor Company. Shows you how to diagnose all Ford troubles by feel, sound, sight, smell and performance. Simple trouble shooting. Permanent repairs. Emergency repairs. Plus, "How to get value from garages."

## MONEY BACK IF IT DOESN'T SAVE MORE THAN IT COSTS!

One minor repair will save the cost ten times over. Read it. Then you decide. If you don't see that you'll save more than the cost, send it back for refund. SEND NO MONEY. Send postpaid. Ask for the Ford Manual. Postman will deliver U. O. D. for \$3.50 plus postage. Or, save postage by sending \$3.50 with order. Send today. Save its cost on your next repair.

**POPULAR MECHANICS PRESS**  
200 E. Ontario, Dept. 90, Chicago 11, Illinois



**DRILL SAW REAM CUT**

**INTERNATIONAL**

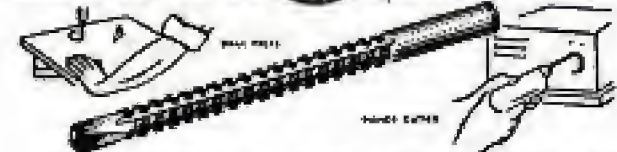

DRILL, SAW, REAM . . . metal, pipe, wood, plastic, Transite, etc. Use with any electric drill, slow drill press, lathe or milling machine. Drills own starting hole—upper part of bit is used to cut, saw or ream circles, oval, squares or scrolls. Easy to operate. Ideal for carpenters, mechanics, electricians, plumbers, hobbyists, many others. Abrasive resistant, high speed steel. Flutes ground from solid. Will withstand severe continuous use without breaking. Resharp-ened at no charge. Takes place of up to \$50 in tools. 1/2" diameter, 2" cutting sections, total length 3 3/4". Available in three types—All Purpose, Wood, Heavy Metal. Specify type needed. Set of 3, \$11.50. Details on request. Shipped same day. Money-back guarantee. Dealer inquiries invited. **ORDER NOW! SEND CASH, CHECK OR MONEY ORDER.**

only **\$3.95** POST PAID

Manufactured and distributed by **INTERNATIONAL TWIST DRILL CORP.** 518 Wyandotte, Rm. 633, Kansas City 5, Mo.

**LIVE LATHE CENTER WITH TIMKEN DOUBLE ROW TAPERED ROLLER BEARING**



- No. 1 Live Lathe Center, the 1 Series type available as optional
- Flared Flanges
- Reamed and Ground 1/2" Flange to Accept
- 1/2" x 1/2" Flange Bearing Assembly to 100 lbs.
- 1/2" overall length. Combined Total 3 Flange Total
- Bearing Housing 1/2" x 1/2" dia.
- Shipping 20-25 lbs.

ONLY **\$9.50** POST PAID (Reg. 27.50) Send Check or M.O. No C.O.D.

Ideal for lathes, milling machines, grinding, wood turning. **SKA TOOL & SUPPLY CO.** Dept. M, 238 Rounford Rd. PHILADELPHIA 19, PENNA.

**EXTRA VALUE** Built to give extra service and extra satisfaction. Free Catalog. **GERSTNER TOOL CHESTS** 454 Columbia St. Dayton 7, Ohio

**Catalog of 3000 Novelties 10c**

Send 10c for amazing catalog of novelties, live animals, scientific novelties, hobbies, sunrakers, planes & boats, toys, magic tricks, joke articles, unusual seeds, gadget time-savers, cameras, optical goods, projectors, movies, lucky jewelry, religious novelties, disques, musical instruments, stamps, coins, puzzles, fortune tellers, radios, auto & bike accessories, telescopes, magnifiers, compasses, banks, smokers' gadgets, artists' supplies, printing sets, airplanes, motors, shockers, knives, billboards, pens, rifles, sports, books, games, plants, etc. Send name, address & 10c to:

**JOHNSON SMITH & CO., Dept. 786, Detroit 7, Michigan**

Regular Price of a Slide Rule \$4 and up

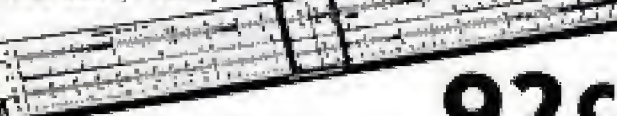

**Slide Rule 92c** and this coupon Add 8c Postage

If you can see a pencil you can use a slide rule. For bookkeepers, accountants, salesmen (figuring commissions, cost, etc.), farmers, housewives, etc. For Armed Forces highly important. Man's most useful tool. Easy to calculate instantly. Multiplying, proportions, division, roots, etc. "High Vision" Clear View Scales. Full 10" Rule. A, B, C, D, C1 and K scales. **FREE** 28-page instruction book on how to get correct answers instantly without pencil or paper.

**Gene Loewy, 545 5th Ave., Dept. 43-K, N.Y. 17** Limit three rules to each coupon.



You can do those **BIG PAY Jobs** with this **LOW COST HOBART**

**"Husky Boy" arc welder** air-cooled engine drive

**Welds Anywhere!** In or out of the shop, the "Husky Boy" can earn bigger profits for you. And you save more on the purchase cost. Lighter weight makes it ideal for using on small service truck for quick emergency calls. For use in the shop, wheels and handles are available at a slight additional cost.

Check these **Low investment HOBART welders too!**

**Full 200 amps. (not skimped)** Specially built for smaller shops requiring lighter weight and lower investment, the "Bantam Champ" gives full 200 amp.

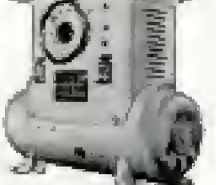

200 Ampers Bantam Champ

**You can "Build Your Own"** You can save even more by "Building Your Own" with this Hobart generator. Just connect the "Build-Your-Own" to your own used auto engine . . . it's perfect for small operations which do not justify a complete, factory built outfit.

**AC Welder with AC Power for tools** The AC-AC Welder and Power Unit lets you do numerous repair jobs where no power is available . . . also furnishes emergency power for electric lights and power tools. 200 or 300 amp. size plus 5KW AC power.

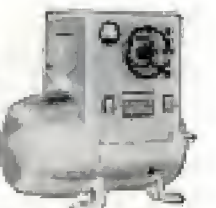

Generator for "Building Your Own"

**AC Transformer type** For improved AC welding performance. Operates on single phase 220 power lines.



Transformer Type AC Welder

**HOBART WELDING SCHOOL** Be your own boss! Learn profitable arc welding at the non-profit Hobart Trade School. Skilled instructors give you on-the-job training. Complete or partial courses with latest equipment. G. I. bill approved. Write for free booklet.

**HOBART BROS. CO., BOX M-24, TROY, OHIO** "One of the world's largest builders of Arc Welders" Phone 21223

**Vest Pocket Guide FREE!**

**Hobart Brothers Co., Box M-24, Troy, Ohio**

Please send additional data on items checked:

"Husky Boy"  "Bantam Champ"  Welders' Vest Pocket Guide

Transformer Type AC  "Build Your Own"

Hobart Welding School  Welding Lessons, \$1.00

NAME \_\_\_\_\_

ADDRESS \_\_\_\_\_

CITY \_\_\_\_\_ STATE \_\_\_\_\_

## NEW CAR

**WIPE** it off every nice day and you'll *never* have to hose it. KOZAK will even DRYwash a nice car that is so dirty you can hardly tell the color of the paint. Been doing it for 28 years now. For people whose cars are *always* clean. This \$2 investment will return you fifty in car-wash savings. And has been so Guaranteed to 10 million buyers since 1926.

Mail Coupon to:

The ORIGINAL  
**KOZAK**

Auto Dry Wash  
REG. PAT. OFF. U.S. and CANADA

99 S. Lyon St., Batavia, N. Y.

... Mail me  1 for \$2  
Postpaid  3 for \$5

City.....Zone.....State.....  
 cash  check enclosed  
GUARANTEED or MONEY BACK

**\$500** in 4 months' spare time

### is what I made with the FOLEY LAWN MOWER SHARPENER

... and I can sharpen all power mowers. No one can go wrong with the Foley machine."—V. J. Patterson wrote us.

Get in this profitable business where you take in CASH right from the start. — and build a steady repeat business too. 99¢ of every dollar you take in is YOUR profit! The Foley handles all makes of hand and power mowers. Leave handles on — with the Foley you can turn out more mowers per hour.

**FREE PLAN** shows how to start — no experience needed. Foley prices are low — easy payments available. Get set now for big profits this Spring and Summer. Send coupon today — no salesman will call.

Send For  
**FREE BOOK**  
HOW TO  
SHARPEN  
POWER  
MOWERS



"In my home town of 5000 I paid for the Foley 4 or 5 times over the first season. I also put a \$1000 bill forward in my new home."  
J. Mathews  
"We sharpened nearly 1000 mowers our first season and gained a reputation for the best work."  
J. W. Kemper

FOLEY MFG. CO.

207-4 Foley Bldg., Minneapolis 18, Minn.

Send FREE BOOK "How to Sharpen Power Mowers", and FREE PLAN on lawn mower business.

NAME.....

ADDRESS.....



### Heated Jacket for Blood Bottles

Lives may be saved in future sub-zero warfare by a new device that keeps bottles of blood warm. Combining a chemical heating pad and an insulating jacket, it was developed by a Marine pilot who saw whole blood freeze while flowing into a wounded man during the Korean fighting. One teaspoonful of water in the chemical heater maintains bottled fluid at 90 degrees in zero weather.

### Two-Wheel Skate

Roller skates with only two wheels provide some of the thrills of ice skating the year 'round. The two large wheels are center-mounted and are made of plastic-rubber. The skate is adjustable in length and has a cushioned ankle strap.



# STOP CHANGING MOTOR OIL!

End this needless expense forever with

**RECLAIMO** Today's most advanced OIL RE-REFINING filter FOR CARS, TRUCKS, TRACTORS.

Continuously cleans and RE-REFINES motor oil as you drive by utilizing motor heat — keeps oil in high grade lubricating condition at all times.

### "RECLAIMO"

- REMOVES SOLIDS (by filtration)
- REMOVES WATER (by distillation)
- PREVENTS Excess fuel dilution
- PREVENTS Acid and Sludge Formation
- ADDS Thousands of Miles to Engine Life

**MAINTAINS** Stable Viscosity **ELIMINATES** All Oil Changes  
 FREE 32-page book "OIL FACTS" with valuable \$1,000.00 offer on page 300. Give us your complete "Reclaimo" story and details of our extraordinary 90-DAY NO-RISK TRIAL OFFER. Write for your copy today!

## RECLEAN FILTER CO.

5023 Elston Ave., Dept. M-2, Chicago 30, Ill.  
 Wm. Schwabge, U.S. Pat. 1,757,923, 1,804,054, 2,008,478.

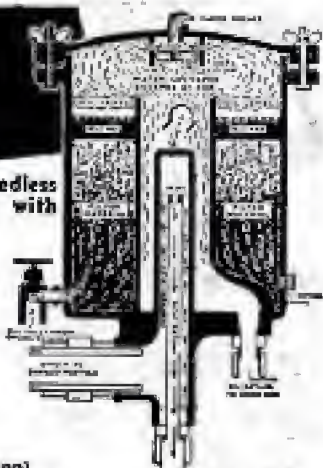

DEALERS WANTED

U. S. BUREAU OF STANDARDS, Bul. 86 States, "Oil does not wear out mechanically."

## 1954 CATALOG — Send 25c

41 models for '54! See World's finest line before you buy. Rated tops in design, styling, performance by 40 experts. '54 Catalog plus booklet "Boat Selection, Operation, Maintenance" \$1.00.

# Custom-Craft

THE ORIGINAL "PACKAGED"

## BOAT KITS

## BOAT PLANS AND FULL-SIZE PATTERNS

Over 100 Modern plans and full size patterns. Racing classes, cruisers, inboards, outboards, sail boats. By famous designers. 6' to 30'. DESIGN CATALOG only 35¢. For Design Catalog plus boat building handbook send \$1.00.

CUSTOM-CRAFT (DEPT. A) BUFFALO 7, N. Y.



## RADIO CONTROL YOUR MODELS

Control Model I - Radio control model of motor race transmitter & receiver. Radio & control equipment. Long range for Alvin, Bear, Jack Models. All three only \$24.95 assembly with our parts & plans. \$29.95

Book - "RADIO CONTROL OF MODEL AIRCRAFT" \$2.95

ONLY \$4.95 RADIOMODELS BOX 36 DEPT. PM BALTIMORE 4 MARYLAND

## RELINE YOUR OWN BRAKES

\$5.25 EACH SAVE UP TO \$25.00!

Buy direct from manufacturer at wholesale prices and save. COMPLETE INSTRUCTIONS sent with ready lined BONDING BRAKE SHOES—no rivets—up to 50% longer wear. High quality brake lining, heavy back substrate. Remit \$2.00 with order—shipped 1-1-1-1. Add 75¢ per shoe deposit on drive shaft. REFUNDABLE promptly when your old rebuildable brake shoes are returned to us within 45 days. F.O.B. Los Angeles. (IMPORTANT) Specify car make, year, model, number of axles. We will mail you printed 1/2 inch square front axle, or rear axle.

### CALIFORNIA BRAKE SHOE EXCHANGE

Dept. P, 1325 S. La Cienega Blvd., Los Angeles 35, Calif.

# PAGE Garden Tractors

## 1954 MODELS

More Work! Less Cost!

• 2100 HP walking and riding machines • Over 60 attachments available! • All enclosed gear with reverse. No belts—no chains!

Also new one-wheel "Danton" model. Low prices — Easy terms. 25 years' experience behind every PAGE — fully guaranteed!



Plows, discs, tills, seeds, cuts grass and weeds, and many other jobs!

Shows over 60 attachments  
 Free Catalog

**PAGE** 1904 S. Bist St. Milwaukee, Wis.

# Build A FIREPLACE



around this scientifically designed steel form which also provides circulating heat and assures perfect Fireplace operation.

## free folder tells how

TELLS HOW TO BUILD YOUR FIREPLACE—Step by Step

- Foundation
- Steel heat-circulating form
- Cold and warm air ducts
- Chimney and flue construction
- Mantel or decorative front



Foundation

ASK FOR BOOK "100 FIREPLACE IDEAS"

Beautiful fireplace designs modern and conventional—shows artistic use of available material.

Enjoy circulating heat and the radiance of an open fire in your Home, Playroom, Cottage or Camp.



Fireplace form set on foundation includes firebox, damper, down draft shelf and smoke dome.

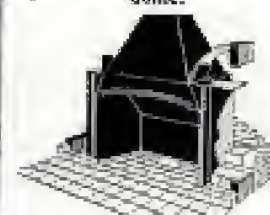

Brick, stone or cement block can be used around the form.

- Send free directions for building heat-circulating fireplace.
- Send Book "100 Fireplace Ideas." Pocket size book, sent free.
- Send larger book, 8 1/2 x 11, beautifully illustrated, 25c.
- Send outdoor fireplace folder with 10 beautiful designs Free.

Name .....

Street .....

City .....

Sold Through Leading Building Materials Dealers

**PRICE FIREPLACE HEATER & TANK CORP.**  
 181 W. Austin Street, Buffalo 7, New York

# THE NEW MODEL TV-11 TUBE TESTER



## SPECIFICATIONS

- Uses the new self-cleaning Lever Action Switches for individual element testing.
  - Because all elements are numbered according to pin-number in the RMA base numbering system, the user can instantly identify which element is under test. Tubes having tapped filaments and tubes with filaments terminating in more than one pin are truly tested with the Model TV-11 as any of the pins may be placed in the neutral position when necessary.
  - The Model TV-11 does not use any combination type sockets. Instead individual sockets are used for each type of tube. Thus it is impossible to damage a tube by inserting it in the wrong socket.
  - Free-moving built-in roll chart provides complete data for all tubes.
  - Photo Jack on front panel for plugging in either phones or external amplifier will detect microphonic tubes or noise due to faulty elements and loose external connections.
- Operates on 105-130 Volt 60 Cycles \$ **47** 50  
A.C. Hand-rubbed oak cabinet complete with portable cover.

**SHIPPED ON APPROVAL  
NO MONEY WITH ORDER - NO C. O. D.**

Try it for 10 days before you buy. If completely satisfied send \$11.50 and pay balance at rate of \$8.00 per month for 6 months—**No Interest or Carrying Charges Added.** If not completely satisfied, return to us, no explanation necessary.

**MOSS ELECTRONIC DISTRIBUTING CO.**  
Dept. D-12, 3849 Teuth Ave., New York 34, N. Y.  
Please rush 1 Model TV-11. I agree to pay \$11.50 within 10 days after receipt and \$8.00 per month thereafter.

Name \_\_\_\_\_  
Address \_\_\_\_\_  
City \_\_\_\_\_ Zone \_\_\_\_\_ State \_\_\_\_\_

## HELPFUL BOOKS

Send post card asking for **FREE** catalog  
Popular Mechanics Press, 200 E. Ontario, Dept. 601, Chicago 11

### BUILD YOUR OWN ARC WELDER OR LIGHT PLANT



**D-C GENERATOR**  
\$15.50 used, good cond.  
Instruc. Incl. 100 amp. weld.  
7' & light plant. 200 amps. 24  
Volts. 200 to 400 H.P.M. Of  
Brand New.....Price \$21.50  
E.M.E. P.O.B. K.C. MO.

CONVERTS TO ARC WELDER 200-250 AMP.  
OR LIGHT PLANT 100, 1000 5000 WATTS

Stock #513 A.C./D.C. Generator, Mfg. by  
General Electric. Rated 1250 Watts, 10.9  
Amps., 115V. A.C. 2000 Amps. 20V. D.C.  
Converts to dependable 115V. A.C. light  
plant and D.C. battery charger. Gov't. cost.  
\$300.00. Instructions incl. Wt. 60 lbs.  
Good, good condition... **\$25.50 NEW \$35.50**

**SOME INTERVOMETER.** Applicable for 24V. D.C.  
and 115V. A.C. To operate lights, displays,  
radio, etc. Can be set to release  
at fixed time interval or split  
timing. Size 3"x6"x3 1/2".  
\$50.00 value. Brand New... **\$8.95**



**CUNO OIL FILTER—BRAND NEW**  
Aircraft type. Filters oil without car-  
tridge replacements. Jet turn handle  
the oil cartridge is clean. Std. 3/4"  
inlet & outlet ports. **\$4.95** incl.  
instructions incl....

Send check or M. Order. Prices  
Inc. h. N.Y. Excise when marked  
outside U.S.A.

GENERAL SALVAGE CO., Dept. 724, 2922 E. 37 St., Kansas City, Mo.

### BEAM ROTATOR MO- TOR

New, reversible,  
geared motor,  
applicable for  
110V. A.C. of  
24 V. D. C.  
Powerful  
geared motor  
for TV aerials,  
Ham. FM an-  
tennas, etc.  
Approx. 9  
H.P.M., free swing.  
Instructions incl.  
Stock #A351 **\$7.95**  
\$50.00 value.

Stock No. 711 D. C.  
Generator R-1 Jack &  
Handle, rated 300 Amps.  
30 Volts. Gov't. cost  
\$300.00. Instruc. for  
converting to welder  
or light-plant incl. **\$27.50**

Photog.  
current  
recorder  
**\$8.95**

**RHEOSTAT #R-27**  
Heavy duty for regu-  
lating the voltage on  
the converted P-1,  
11-1, Welder, & A.C.-  
D.C. type **\$6.95** post  
paid



Lockheed Aircraft Co. photo

## Work Apron Can Stop Bullets

Made of glass-coated cloth, a new light-weight apron protects workers against metal particles that may be thrown from high-speed milling and cutting machines. It can stop a .38-caliber bullet fired from eight feet away. Laminated with a special resin, the aprons vary in thickness from 3/8 to 1/2-inch and weigh less than three pounds. The 25-percent resin content of the laminate cushions the shock.

## Slide Projector

Slides are revolved backward or forward to the lens in a new projector that holds four slides on a narrow metal drum. Light shining through a translucent glass screen below the replacement slot gives the operator a right-side-up preview of the next picture as he replaces each slide at the top of the drum. Glass, plastic or paper slides are automatically positioned.

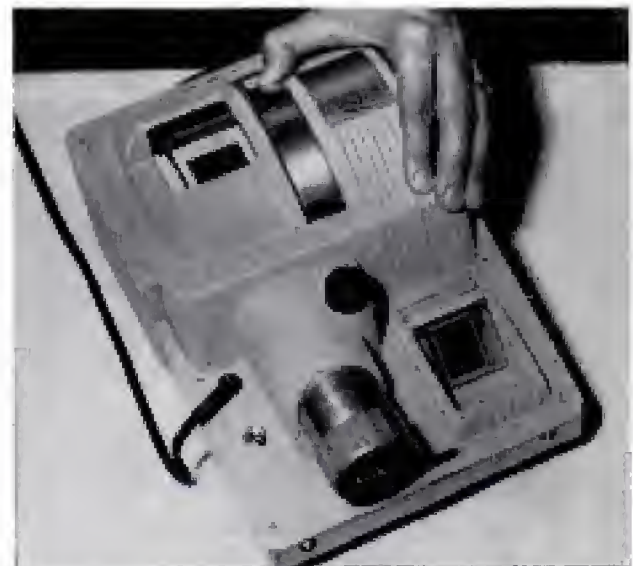

# MODERNIZE YOUR WALLS quickly and easily!

INSTALL NEW MARLITE PLANK AND BLOCK Remodeling a kitchen or bathroom . . . a recreation room or extra bedroom? Do-it-yourself the easy, economical way with new Marlite Plank and Block. This easy-to-handle paneling is installed quickly over old walls or furring strips. Exclusive tongue and groove joint conceals all fastening.

## Marlite saves you money, too!

The soilproof baked finish never needs painting; cleans with a damp cloth. Planks (16" x 8") and Blocks (16" square) are available in beautiful "companion colors" styled by Raymond Loewy Associates, plus 4 distinctive wood patterns. See your building materials dealer or mail coupon for free full-color folder.

MARLITE PLANK AND BLOCK PATENT APPLIED FOR

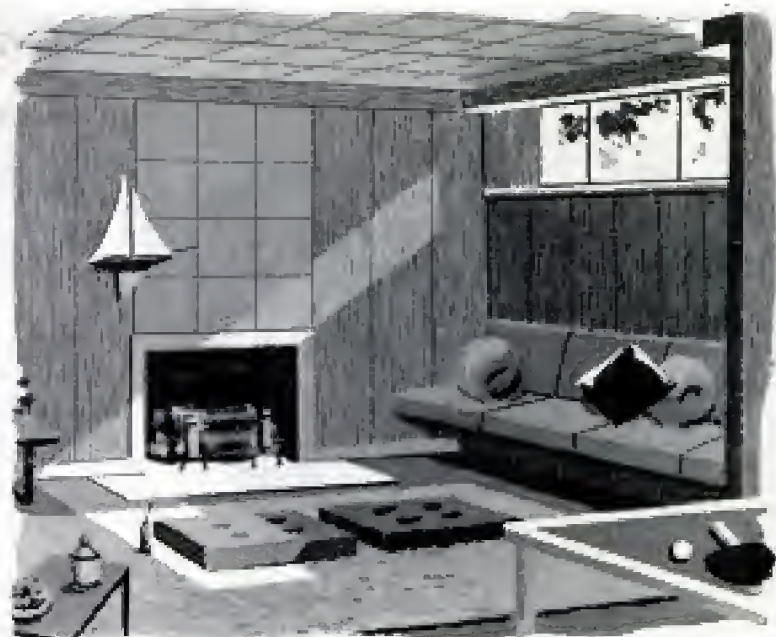

MARSH WALL PRODUCTS, INC., DEPT. 242, DOVER, OHIO  
Subsidiary of Masonite Corporation

Please rush free full-color folder showing how I can modernize with new Marlite Plank and Block.

Name \_\_\_\_\_

Address \_\_\_\_\_

City \_\_\_\_\_ State \_\_\_\_\_

**Marlite**<sup>®</sup>  
PREFINISHED  
WALL AND CEILING PANELS

## BUILD YOUR OWN POWER MOWER



**With Parts We Furnish**  
Why break your back mowing field or lawn? Now anyone can save time, money and effort by building their own Power Mower. Build it to fit your needs, in a short time without special tools.

**PULLS ITSELF, STEERS ITSELF**

WRITE FOR FREE BUILDING INSTRUCTIONS—NO OBLIGATION

T & H Mfg. Co., 811 E. 31 St., Dept. M2, Kansas City, Mo.

Say You Saw It in Popular Mechanics

## CAUSE OF STARTING FAILURE... AT A GLANCE!



**MAGIC EYE AT YOUR FINGERTIPS**  
**IGNITION CONTROLLER** — Amazing new simple invention, a wonder of modern electronics fits easily into your dashboard. Instrument panel lights up RED the moment you press ignition if you have stalled due to ignition failure. No battery or metal connections. This simple instrument electronically picks up magnetic waves from ignition circuit without plug-in. Enhances dashboard appearance and works mess-free. Full simple directions—anyone can easily install. Don't be without **IGNITION CONTROLLER**.

Thousands of cars have it, only \$4.95 postpaid. Rush check or Money Order for immediate delivery.

### IGNITION CONTROLLER

128 WEST 87TH ST. (APT. 21) NEW YORK 24, N.Y.

**MALL Model 143T**  
1/4" ball bearing drill—\$36.00, f.o.b. Chicago.

## ONE MALL DRILL AND ATTACHMENTS GIVE YOU A COMPLETE HOME WORKSHOP

These are just a few of the many MALL attachments available to mechanize your home workshop. Get a good drill...a MALL drill. Then add attachments as you go along. Pretty soon, your shop will be complete...ready for 1001 different jobs.

**MALL TOOL COMPANY**  
7805 S. Chicago Ave., Chicago 19, Illinois

Send me more information about MALL drills and attachments.

Name \_\_\_\_\_

Address \_\_\_\_\_

HO-66

REPLACE YOUR OLD WORN  
OUT CHUCK WITH A



- ENTIRE CHUCK BODY HARDENED
- JAWS NICKEL CHROME MOLY ALLOY STEEL
- INDIVIDUALLY TESTED FOR ACCURACY
- STURDY ONE PIECE CONSTRUCTION

**SOLD BY HARDWARE DEALERS**



SUPREME PRODUCTS, INC., 2222 S. Columet Ave.  
Chicago 16, Illinois  
The chuck that lives up to its name... SUPREME

Say You Saw It in  
**POPULAR MECHANICS**

building?

... use

**FIR**  
**PLYWOOD**

Gives you more house for your money. Best for sheathing, siding, paneling, built-ins. For "Plan with Plywood", send 10c to Douglas Fir Plywood Assoc., Tacoma 2, Wash., or see your lumber dealer today!

Buy Only DFPA-Graded Panels



### Sound-Tape Album

Three reels of sound-recording tape are stored in a book-style album that lists its contents on the cover. A slip-out card in the front summarizes the contents, while full cataloguing space for each recording is provided on the side of the pack. Bound in durable leatherette, the album is available in two sizes, for five-inch reels and seven-inch reels. The reels rest on their edges, a recommended practice for magnetic-tape storage.

### Two-Way Snooper Flashlight

Ever try to poke your flashlight around a corner to find what dropped behind the refrigerator? There wasn't room for both you and the flashlight to peer down the narrow crack. A new two-called flashlight with a tough plastic case solves this problem. With everything locked, it operates like a standard flash, throwing a 1000-foot fixed focus beam. But along one side, a flexible side extension arm rests in a socket. Raise the arm and the front light goes off. A tiny bulb on the end of the flexible arm goes into action, pin-pointing light where you want it.





# LIFE-LONG...

The WORLD'S ONLY  
10 YEAR GUARANTEE BATTERY



## AMAZING EUROPEAN INVENTION

- 1 Gives up to 2000 Amps
- 2 Instant Power Output
- 3 Self Recharging

### FEATURING:

Galvanic Cell Shields • Cadmium Alloy Grids • Capillary Separators • Plates Hydro Set with activated oxides • European Valtic Plate Construction • Built-in water recapturing device • Baffle Plate Vents • Deep Well Water Reservoir.

Notarized Independent Lab reports and automotive editor prove the following facts on LIFE-LONG BATTERIES:

- ✓ 300% Greater Capacity.
- ✓ Self Generating—Recharge in 10 seconds after discharge.
- ✓ Instant Amperage Output of 2000 Amperes at 40° below zero.
- ✓ Amazing Watt-Hour Capacity.
- ✓ Develops full rated capacity of 6 volts at 250 amperes at 40° below zero.
- ✓ Only battery with a money back free replacement feature in Guarantee.
- ✓ Longest guarantee of any battery in the world (full 10 years).

6 VOLTS . . . \$29.95      12 VOLTS . . . \$34.95

**IMMEDIATE DELIVERY . . . . . NO DELAY**  
DEALER INQUIRIES INVITED. MAIL AND PHONE (415) 8-4655 ORDERS ACCEPTED.

## LIFE-LONG BATTERY MFG. CORP.

11766 W. Pico Blvd., Dept. P-2      Los Angeles, Calif.

**Life Long Battery Mfg. Corp.**  
11766 W. Pico Blvd., Los Angeles, Calif.  
Gentlemen:  
After having read the report of the test at the independent testing laboratory, conducted by an institute would be wise to test it ourselves. These results, as you already know, were even better than the ones submitted to us. We have then decided to hire the services of the laboratory you have ever used to verify the results. These results again verified our opinion you have ever held about our battery. We are sending you a certified and notarized copy of the tests. In our opinion you have an excellent battery and with normal care should last your guaranteed period of 10 years. The recuperative characteristics of the Life Long Battery are amazing.

Sincerely,  
**JOHN WERNER**  
Technical Editor of  
*Motor Life Magazine*

### WE PAY ALL SHIPPING COSTS

#### LIFE-LONG BATTERY MFG. CORP. DEPT. P-2

11766 W. Pico Blvd.  
Los Angeles, Calif.

- 6 volt \$29.95 (including tax)
- 12 volt \$34.95 (including tax)

for \_\_\_\_\_  
Western Union, Telegram Co.  
 I enclose cash, check, or money order, you pay shipping cost.  
 NAME \_\_\_\_\_  
 ADDRESS \_\_\_\_\_  
 CITY \_\_\_\_\_ STATE \_\_\_\_\_

### ALLEN 1-TON POWER BENCH TYPE PUNCH PRESS

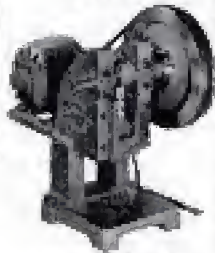

A RUGGED, RELIABLE PRESS FOR SMALL WORK  
Cuts cost and saves money on stamping, forming, drawing, etc.  
Overall height—17 1/2"  
Base size—8 1/2" x 30"  
Die bed—5 1/2" x 31 1/2"  
Ram face—1 1/2" x 3 1/2"  
Ram stroke—3 1/2"  
Positive 3/4" ram adjustment.  
Sturdy, single pin, non-repeat hand lever clutch. V-belt drive. Total weight 165 lbs.

Price **\$125.00**  
F.O.B. Clinton, Mo.  
(less motor)

**30-DAY MONEY-BACK GUARANTEE**  
Full year warranty against defects. Send your order today. Price includes motor bracket, V-belt, motor pulley. Free Circular.  
Alva F. Allen, Dept. PM, Clinton, Mo.



### Here now for 1954

"Home Is Where You Take It" with America's leading all-steel insulated mobile home, the new HOWARD for 1954! Time-tested from Alaska to Florida, now better by far—for you and your car. For details write HOWARD Industries, Box 2188 . . . Dept. 21, Saginaw, Mich.

## Howard MANSION COACH

HOWARD INDUSTRIES INC., SAGINAW, MICHIGAN

### 2 DRILLS in 1



\$13.95  
plus post

This attachment gives you two drills in one. It converts any 1/8 inch electric drill to 1/2 inch capacity. Reduction gears reduce the drill speed 5 to 1, the average speed of a 1/2 inch drill, and thereby increases the power. Absolutely indispensable for all shop work and home craftsmen.

Send check or Money Order  
Satisfaction guaranteed  
Order yours now

**G. M. CO. MANUFACTURING, INC.**  
1308 43rd AVE.  
LONG ISLAND CITY 1, NEW YORK



### earn BIG PROFITS

#### Sharpening Hand Saws

The Foley Saw Remover cuts perfect new teeth right over old ones in less than 1 minute, without removing saw handle. Saves you HALF your filing time. Takes all hand saws 4 to 16 points per inch. Relieves eye-strain. No experience needed.

**FREE** Foley Price Guide of saw sharpening charges. A valuable chart of actual prices. Send coupon today. No substitution with call.

**FOLEY MFG. CO.** 270-4 Foley Bldg.,  
Seed PRER Price Guide and Foley Remover circular.  
Name \_\_\_\_\_  
Address \_\_\_\_\_

## 20X Coated Lens TELESCOPE

IN GENUINE  
PIGSKIN CASE

**\$7.95**

postpaid

**Mk. II**



Our most universally popular telescope with hunters, sportsmen, boat owners. A superior quality all metal instrument, finely finished, rust and salt spray resistant. Full coated oversize objective lens, pinpoint extension focusing. A big, powerful scope, a lifetime possession. Shipped in lined and fitted, genuine pigskin carry case. Send check or M.O. 1/2 deposit on C.O.D.'s. 10-day money back guar. Calif. resid. add 8% state tax.

**FREE — 44 PG. OPTICS CATALOG**

Down-to-earth prices on all optics—made to our field specs. by the Japanese optical industry. Free on request or with your order.



**The AKRON** 72 Akron Bldg., 4979 Sunset Blvd.  
Los Angeles 27, California



*"I Love to Garden  
with my  
ROTO-HOE"*

You, who enjoy using the easy-operating ROTO-HOE. And it's still easy to own—fits for the low 1947 price of only \$13.95, complete, ready to work for you.

**ROTO-HOE**

**EXTRA DIVIDENDS.** Besides the low first cost, there's extra saving because you use the same basic Lawson power unit to operate a complete line of low cost attachments—all easily interchangeable in minutes, and thoroughly "action proven." You can pump, spray, saw wood, throw snow, mow, trim, and edge lawns as well as till and cultivate.

**GET THE FACTS** in our new color catalog, with name and location of nearby dealer.

**START YOUR OWN BUSINESS.** If you are a merchant-cally-minded young man who would like to start his own dealer business selling and servicing ROTO-HOES, there may be an opportunity for you in your community. Write us today.

**ROTO-HOE & Sprayer Co., Box 19, Newbury, Ohio**



**BUILD FIBERGLAS-PLASTIC BOATS**  
(without using molds)

New patented process — write **SPEED-CRAFT**, 2450 Emerson Ave., Off Square Lake Road, Pontiac, Michigan.

*Say You Saw It in Popular Mechanics*

**How to  
cut glass**



Simple instructions make glass cutting easy and easy. Free booklet tells how, shows many uses. Limited printing. Free copy is yours if you write now. Send handy coupon today!

**FREE**

**MAIL THIS HANDY COUPON RIGHT AWAY**

**Red Devil Tools, Irvington 11, N. J.**

Please send free copy of Booklet HT-806

"How to Cut Glass."

NAME \_\_\_\_\_

ADDRESS \_\_\_\_\_

CITY \_\_\_\_\_

STATE \_\_\_\_\_



## Twisted Lines Grip Wash

Clothespins are eliminated by a device that fastens laundry to a special clothesline. As the small cylinder is moved along a double, twisted line, it opens the wires so that clothes can be slipped in and then closes them to hold the laundry. Removal entails the same process in reverse. On a pulley line, the device is anchored to the pulley and automatically operates the line as it passes through. To remove clothes, the pulley handle is simply cranked and clothes drop into the waiting basket.

## Pocketknife "Chow Kit" *See Letter*

Campers and picnickers can unfold all their eating utensils from a new kit that looks much like an ordinary pocketknife. The kit is built in three sections which are held together by lugs that slide into slots. When the sections are slipped apart, one unfolds to form a spoon, another a fork, and the third a knife. An extra blade in the knife section serves as a can and bottle opener.





## STOP THAT SQUEAKY FAN BELT for only 50c



★ A few drops of Cling-Surface stops slipping, stops squeaks, makes belts last longer. Good for all belt driven power tools and appliances, too! Sold at service stations, auto parts and hardware stores. If your dealer can't supply you

Send 50¢ to:

**CLING-SURFACE CO., INC.**  
1047 Niagara St. Buffalo, N. Y.  
CANADIAN READERS SEND 75¢

## 72" Flexible Shaft WOVEN WIRE CORE



USE AS ELECTRIC DRILL

**REAL BARGAIN**—cannot be duplicated for \$13.00. Coupling fits 1/2" or 3/4" motor shaft (state which); other end fits standard chuck. Durable, heavy. Use it for grinding, polishing, buffing, drilling, etc. Chuck for same — \$1.25.

**only \$6.95**

SEND NO MONEY—ORDER TODAY. This low price can't last. Pay postman—plus postage. Send check or money order and we will ship P.P. prepaid. Money refunded if not satisfied.

**L. C. DOWNEY—Dept. P.M.**  
8004 Tramore Ave. • Phila. 18, Pa.

### "HANDY TIPS FOR HANDY MEN"

BOOK OF HINTS to make home repairs and hobby projects easier. Send 25 cents in coin to: THE BLACK & DECKER MFG. CO., Dept. H2M, Towson 4, Maryland.

### What to Make with CONCRETE



Even little concrete jobs cost big money — mostly for labor. Get Popular Mechanics' **WHAT TO MAKE WITH CONCRETE** and save all the labor cost while making your home or farm shabby-shops. Book shows all—in all — how to make the right mixture, plans, apply and gives 50 professional short cuts. Hundreds of pictures. Only \$2.00 postpaid. Order today. Money back if not pleased.

POPULAR MECHANICS PRESS, Dept. PM9, 200 E. Ontario St., Chicago 11

Say You Saw It in Popular Mechanics

## MEMO

Clean the carburetor with GUMOUT and KIT...



**Eliminate hard starting, rough idling, stalling, bucking and high gas consumption caused by a dirty, gummed up carburetor.**

It's easy to clean the carburetor on your car with GUMOUT and KIT. Do it yourself—WITHOUT TAKING THE CARBURETOR OFF THE ENGINE. Engine performance will improve immediately. GUMOUT and KIT includes a pint of GUMOUT and a life-time service kit to feed quick-cleaning GUMOUT directly into the carburetor. Sold by leading AUTO SUPPLY STORES. If local dealer can't supply you, order direct. GUMOUT and KIT, complete, \$3.95 postpaid. GUMOUT refills, \$1.50 per pint can.

**GUMOUT DIVISION**  
Pennsylvania Refining Company  
2671 Lybun Road, Cleveland 4, Ohio

## D. C. ARC WELDER

AT A.C. TRANSFORMER WELDER PRICE



**\$350.00 VALUE**  
**ONLY \$85.00**  
Fully Guaranteed  
200 Amps. Belt Driven  
Model No. LG-200 Brand New!

**WELDS—CUTS—BRAZES** anything from Tractor frames to Sheet Metal

- For stationary or portable use
- Operates at 3000 RPM from 60/50 HP Electric Motor or 7 1/2 hp greater Gas Engine
- Reactor-type series winding for EVEN ARC
- Rheostat for pin-point heat control
- Output is 30 to 200 Amps.
- Straight or reverse polarity
- Uses 1/16" to 3/16" Electrodes
- Includes 2-groove V Belt and simplified instructions

**COMPLETE WITH ACCESSORIES** shown, including two 15 ft. cables plus sample rods (8 lbs. wt. 98 lbs.)... **\$98.50** f.o.b.

---

## AIR COMPRESSOR

SURPLUS! NEW Release!  
Original Gov. Cost \$350.00



Finest 2 HP TWIN CYLINDER Industrial Unit ever built! **\$129.00** f.o.b.

Portable! Fully Guaranteed 6.3 C.F.M. Handles largest industrial and commercial applications

- BENDIX-WESTINGHOUSE Twin-cylinder compressor
- HIGGINS & STATION 2-HP. 4 cycle "Kick" or rope start engine
- TWO independent air outlets (one for high pressure to 200 lbs.—one controlled by regulator from 0 to max.)
- Large Two Gauge • Safety release Valve
- Automatic governor and unloader keeps pressure constant without stopping engine
- Hollow frame acts as air reservoir assures fast large supply of OIL-FREE air with absolutely NO PURSATION!
- TWO 15 ft. heavy-duty hoses included

ALSO AVAILABLE! Same built with 1-HP Electric Motor, 110-220 volts, 60 cy. . . . . **\$129.00** f.o.b.

ORDER DIRECT FROM THIS AD! Satisfaction Guaranteed!  
Send for CATALOG of Motors and Electrical equipment  
ROBERTS ELECTRIC CO., Dept. 139, 849 W. Grand, Chicago 22, Ill.

## FREE BOOK CATALOG

Everything—shop tools, hunting, fishing, making money at home, concrete work, welding, mail order, plastics, painting, carpentry, photography, boat building, gardening, auto repair, hobbies, home building—is listed in the new 40-page 1954 catalog of easy-to-understand Popular Mechanics books. Write for your free copy now! Dept. CT2.

Popular Mechanics Press, 200 E. Ontario, Chicago 11

# LOW COST WOOD PANELS GUARANTEED FOR LIFE!



**Beautiful Weldwood Plankweld®—easy to install—see it at your lumber dealer's now!**



**DO IT YOURSELF** Plankweld is genuine wood wall paneling, factory prefinished to soft deep lustre. Ready for immediate installation; each package contains special metal clips which are nailed to wall to hold panels in place. Panels are edge grooved and overlap to conceal clips and nailheads. If

you can hit a nail or saw a piece of wood you can install Plankweld easily. Can be installed on any nail-holding wall or directly to studs without furring. *Plankweld is guaranteed for the life of your home!*

**CHOOSE THE WOOD YOU WANT.** 16 $\frac{1}{4}$ " x 8' Plankweld panels come prepackaged (108 $\frac{1}{2}$  sq. ft. to package) and are available in birch, Philippine or Honduras mahogany, plain sliced oak, and walnut,  $\frac{1}{4}$ " thick. Now you can have a beautifully paneled wall for less than you think. See them all at your lumber dealer's or at any one of the 60 United States Plywood or U.S.-Mengel Plywoods showrooms located in principal cities, or write for complete information.

## **Weldwood®**

Plankweld Paneling



**UNITED STATES PLYWOOD CORPORATION**

World's Largest Plywood Organization

Weldwood Building, 55 W. 44th St., New York 36, N.Y. and

U.S.-MENDEL PLYWOODS, INC., Louisville, Kentucky



## **Tiny Typewriter**

Built in Germany, a new typewriter is so small the operator can hold it on his lap during use. The midget machine fits in a case about the size of an ordinary briefcase. The case also holds stationery and other writing equipment.

## **Electric Stamp Vendor**

Postage-stamp sales are speeded with a post-office machine that is dialed like a telephone to produce the denomination and quantity of stamps a customer wishes. The dials are connected to a unit under the stamp-window counter. The stamps pop out from slots in the counter and are torn off by the customer. Up to six different kinds of stamps can be dialed.



Millions Enjoy His Program Every Week on TELEVISION!  
More Will Enjoy His New Popular Mechanics Book!



Make Boys and Girls Happy While They Learn

give them

# Mr. Wizard's Science Secrets

by TV's Famous Don Herbert



**FREE!**

Name Stamped on Cover  
in Gold Letters  
Give Mr. Wizard's Science  
Secrets as a gift with re-  
cipient's name stamped in  
gold FREE.

## 150 Mystifying Experiments With Everyday Things That Help in School and All Through Life!

Millions of children enjoy Don Herbert's science experiments on television. Now they can enjoy them more in his own brand-new book, *Mr. Wizard's Science Secrets*, with Mr. Wizard himself and his helpers, Willy and Betsy. Get this fascinating, entertaining and instructive book for your young people. Let them learn exciting scientific facts by doing Mr. Wizard's experiments themselves, using only simple materials, most of it in your kitchen and bathroom cabinets. Never before such a book. It entertains as it educates. It makes fun out of learning facts. Give your children—your friends' children—the educational advantages and joyous pastime which Mr. Wizard's book affords. See special gift offer—books will be personalized with recipients' names in gold FREE.



Above: Mr. Wizard in a demonstration of oxygen and combustion. Center: With helpers, Willy and Betsy, watching bottle fountain and action of carbon dioxide in bubbles, Willy and Betsy in a test that proves sound isn't so easy to locate. Hundreds of pictures like these in Mr. Wizard's book.

### Some of 150 Projects and Experiments Explained and Pictured for Boys and Girls to Do at Home

- |  |  |
|--|--|
| Why salt melts ice.                        | How to make . . .                      |
| Experiments with vacuum.                   | Static electricity                     |
| What is air, oxygen, atmospheric pressure? | Water boil with an ice cube            |
| What makes an airplane fly?                | Your own telephone with tin cans       |
| What is gravity?                           | Music boxes                            |
| Why does hot air rise?                     | Compasses                              |
| What is steam?                             | Your own telegraph set.                |
| Why does corn pop?                         | Water boil in a paper box              |
| What are molecules?                        | Fire extinguishers                     |
| What is carbon dioxide?                    | How to carry sound in your finger tips |
| How to write with invisible ink.           | And more than a hundred others         |

264 Fascinating Pages • 249 Illustrations — Made for This Book

### Answers Hundreds of "How" and "Why" Questions

Mr. Wizard answers most of the questions children ask. They're all in his book. His answers and demonstrations are so fascinating that youngsters actually have fun learning the facts they should know and they never tire of learning. Parents and teachers will find the book a helpful treasure.

### Science, Physics, Chemistry in Fascinating, Joyous Form

Mr. Wizard makes games out of science, physics and other subjects that keep young people occupied and interested for countless hours. He has special appeal to both boys and girls of all grammar school ages and imparts information that will be helpful to them now and throughout their lifetimes.

## Order Today! Use Coupon to Get Mr. Wizard's Book, Include Name for FREE Gold Stamping.

Order this big, beautifully illustrated, printed and bound book now. It is the GIFT BOOK of the hour, with the added feature of the recipient's name in gold. Give it to all young people for birthdays, Christmas and other gift occasions—for merit awards—for good conduct—or just to help a boy or girl advance. Only \$3.00 postpaid. Order on the handy coupon.

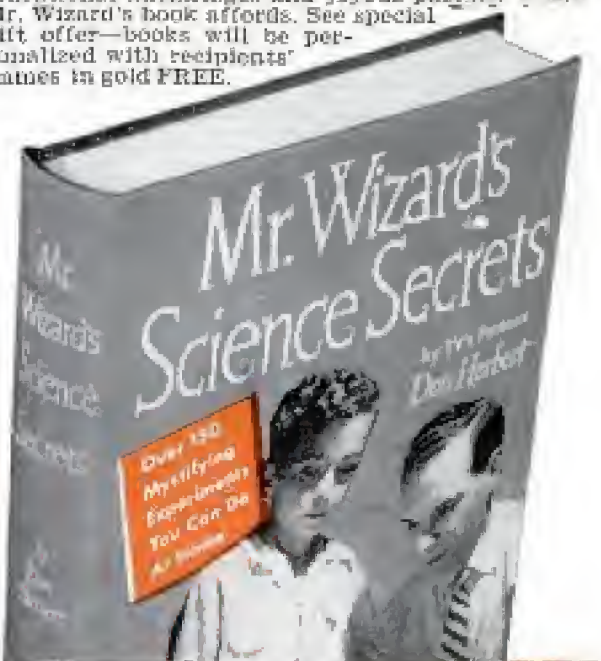

### POPULAR MECHANICS PRESS

200 East Ontario St., Chicago 11, Ill.

Please send at once, delivery prepaid, \_\_\_\_\_ copies of *Mr. Wizard's Science Secrets* at \$3.00 each. Stamp names in gold without extra charge under your special FREE offer. Remittance enclosed \$\_\_\_\_\_

Name \_\_\_\_\_

Address \_\_\_\_\_

City \_\_\_\_\_ State \_\_\_\_\_

Print name for gold stamping on this line. Use margin for extra names if required.

# At Last! A PORTABLE Motor-Welder

9 TOOLS IN 1



**Motor-Weld Model 1A**

—Recommended for hobby and home work. Comes on three-trial above. Plugs into any 110 Volt AC or DC Line. Amperage Output: 30, 50, 75, 100 Amps. Size: 10" deep, 8 1/2" high, 17" wide. Shipping Weight 45 lbs. Price P.O.B. Chicago, Ill. Less Accessories \$49.95. Complete with Accessories \$54.95. Post Battery Charger Attachment \$5.00 Extra.

## HAS SELF-CONTAINED MOTOR GENERATOR JUST LIKE BIG PLANT UNITS

**MOTOR WELD** is the only known motor-generator type unit that has its **Motor-Generator** in self-contained, yet has light-weight "Pickup" Portability and sold at transformer price levels. Low cost, universal operation. No special wiring—just plug into any 110 volt AC or DC line (any style) and it's ready to test. Its portable **POWER** UNIT can be used to connect saws, grinders, etc. Other models 1100-2200 amp.—Cart Models, etc. available.



**Porte-Weld Model 2A**

—Amperage Output: 50 to 140 Amps. Input: 110-220V AC or DC. Line Draw: 24 Amps. 60, 240 or 3 Phase Line. Straight or Reverse Polarity. 3 Welding Heads. Size: 12 1/2" x 12 1/2" x 15". Shipping Weight 55 lbs. Price P.O.B. Chicago, Ill. Less Accessories... \$85.00. Complete with Accessories \$95.00. Post Battery Charger Attachment \$5.00 Extra. Accessories include—300 Amp. Electrode Holder, Helmer, Ground Clamp, Sanding Buffer, Sample Electrodes, V-Paltes, 3" Welding & Ground Cables, and Instruction Booklet.

Send for **FREE Literature**  
**10-DAY FREE TRIAL**  
**90-Day Warranty**  
**On All Machines**

Send resistance with order: will ship C.O.D. 10 deposit!

- ✓ WELDS
- ✓ BRAZES
- ✓ GRINDS
- ✓ SANDS
- ✓ POLISHES
- ✓ BUFFS
- ✓ BRUSHES
- ✓ POWER UNIT
- ✓ CHARGES BATTERIES



**GENERATOR SALES CO. • 1627 N. Damen Ave. • Dept. P • Chicago 47, Ill.**

## SAVE MIDDLEMAN'S PROFITS ...buy DIRECT from C&H

### LIGHT PLANTS

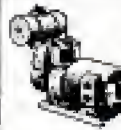

1000-1200 w AC, 115 V, 60 cyc. Powered by rugged 2 1/2 hp easy-starting Continental gas engine. No 30% for just plug in, ready to go. Complete with 12 v starting winding. Easily connected for push-button battery starting. Fully guaranteed, easily worth \$325. Your Factory Price only \$184. Other bargain price models in stock, 300, 1500, 2500, 5000 w etc. SEND FOR FREE BROCKET WITH VITAL FACTS ON HOW TO SELECT PROPER SIZE FOR YOUR JOB.

### BOOSTER FANS



Fit any 8" to 12" furnace pipe. Mounting frame, 7" blades, 110v motor, 60 cyc, 1550 rpm with 6" cord. Silent operation. Easy to install. Warm those rooms with long runs. List \$14.95. Our price... \$6.95; 10w for \$11.95; 30w for \$14.95. Buy one for each room! REGISTER FAN for hot or cold air with bracket holder to mount motor, 7" blades, 6" cord ONLY... \$7.50; two for \$12.95; three for \$16.95.

Here are only a few big 5 5 5 savings! More in our catalog!

- |                 |                   |                  |                   |
|-----------------|-------------------|------------------|-------------------|
| Air Compressor  | Electric Motors   | Hand Truck       | Rubber Cable      |
| Air Tank        | Electric Switches | Hydraulic        | Rubber Wheels     |
| Blow & Tackle   | Elevator          | Cylinder         | Saw Tables        |
| Blowers         | Drawing           | Hydraulic        | Shower Sprays     |
| Bomb Trailer    | Elevator Incline  | Jack             | Starters          |
| Buzz Saw        | Fans, Exhaust     | 1 Beam Trolley   | Tools             |
| Compressor      | Fans, Heat        | Lawn Mower       | Transformers      |
| Accessories     | Booster           | Sulky            | Whiting Roll      |
| Clutches        | Gas Engines       | Magnetic Starter | Wilson Vice       |
| Conveyors       | Generators        | Mail Chain Saw   | Wrench, Electric  |
| Delta Tools     | Grinders          | Mail Grinder     | Wrench, Hand      |
| Drop Cords      | 1/2 Ton Wagon     | Pumps            | Fire Extinguisher |
| Electric Hoists | Male Fire Pump    | Reduction Gear   | 4 Wheel Trailer   |

Get this catalog! 72 pages packed with useful charts, information, more than 1100 text and equipment items at money-saving, factory-to-you prices. Send 25c (refund with first order) or write on company letterhead for free copy.

## C&H ELECTRIC MACHINE Co. Inc.

434 Q W. Juneeu Ave., Milwaukee 3, Wisconsin

## \$2.95 OR 2 FOR \$5.00!

Complete tested and guaranteed. Write for list on all types of telephones and parts. All shipments F.O.B.

**TELEPHONE ENGINEERING CO.**

Dept. 2A Simpson, Pa.

## 275 DO-IT-YOURSELF BOOKS—CATALOG FREE

Do-it-yourself books on painting, home repairs and improvements, carpentry, house planning and remodeling, interior decorating, concrete work, gardening, garage building, home workshop, power tools, television, plumbing, electricity, boat-building, automotive repair, hobbies, upholstery, furniture building, photography, etc. Dept. DN-1 Popular Mechanics Press, 200 E. Ontario, Chicago 11

## Save on all PLUMBING JOBS

When You Build - When Making Improvements - Repairs - Maintenance



### Get POPULAR MECHANICS Home Plumbing Guide



How to plan plumbing installations, select materials and fixtures.

How to save money on all plumbing jobs using approved methods.

Easy to Do Professional-Like Jobs and Save Over One-Half

Get the Popular Mechanics HOME PLUMBING GUIDE. It shows how you can do every kind of plumbing job yourself and save from a few to hundreds of dollars. Covers plans, layout, installation, maintenance and repair. Shows what materials to get and use, where to get them and how to do a proper job with approved methods. Few, other than the simplest tools are required and

some of these can be rented. Don't pay high prices for work you can do yourself. Get the HOME PLUMBING GUIDE for only \$3.50. You will be amazed how jobs you thought difficult are simplified.

Clip This Ad and Mail. Money

Back if Not Pleased

Invest only \$3.50. Use the book for 7 days. Then if you are not satisfied return it for full refund of your money. Sent C.O.D. U.S.A. only if you prefer.



### 15 Ways to Save Money

- All about modern home plumbing
- How to use plumbing tools
- Getting acquainted with pipe
- Planning home plumbing systems
- Installing and maintaining home drainage systems
- Private sewage disposal systems
- Causes and cures of drainage troubles
- Installing home water lines
- Private water supply systems
- Water heaters
- Water Conditioning
- Water system troubles and cures
- Installing and caring for fixtures
- What to do with valves and faucets

Over 500 How-to-do-it Pictures Guide You

POPULAR MECHANICS PRESS, Dept. HPG-10, 200 E. Ontario St., Chicago 11

## HELPFUL BOOKS

Send post card asking for FREE catalog

Popular Mechanics Press, 200 E. Ontario, Dept. 601, Chicago 11

## Look... 3000 MILES OF TELEPHONE WIRE at 1947 PRICES!

**7th ANNIVERSARY SALE**  
We were the original National dealer in surplus telephonic equipment and have specialized continually in phone equipment since 1947. During our Anniversary Sale... our wire is rolled back to 1947 PRICES. At today's real phone wire per 1,000 ft. is approximately \$32.50 wholesale. Buy 1 mile (5,280 ft.) for \$16.00. COMPARE THIS PRICE!  
**ALL PURPOSE—ALL WEATHER** Designed for tough usage by U.S. Signal Corps, perfect for Telephone companies, industry, engineering projects, ranches, etc.  
W-108 2-1/2 gauge, 2-conductor, each cond. copper-steel constructed rugged insulated for weatherproofing.  
Send Check or M.O. • No C.O.D.'s • All Prices F.O.B. Sacramento

GR. 1 Unused, excellent condition, mile reels 15,280 ft., 1 1/2 lbs. \$16.00, 7 1/2 mile reels 12,440 ft., 1 1/2 lbs. \$9.00.  
GR. 11 Unused, good condition. Mile reels, \$11.50, 1/2 mile \$6.50.  
W-130 2-1/2 gauge, New 2-conductor, copper-steel, plastic insulation wire, 10,560 ft. reels \$16.00, 3,500 ft. reels \$16.00.  
**EASY TO INSTALL TELEPHONES, RING AND TALK UP TO 20 MILES**  
EEN Army Field Telephones, factory conditioned—like new... per pair \$42.50.  
EE-01 Field telephones, factory checked... per pair \$34.50.  
SACRAMENTO, CALIFORNIA

ORDER BY AIRMAIL TO DAY—no wait's fast at these prices—  
Write for free folder—MANY LOW-COST PHONES FOR THIS SPECIAL SALE.  
**AS LOW AS . . . \$11.50 Per Mi.**

Perfect  
TV Pictures—  
ON ALL CHANNELS

# 150

Miles or more  
from TV Stations  
UHF and VHF

**FINCO® 400-A**  
Double CO-Lateral  
TV ANTENNA

WRITE TODAY FOR  
Interesting Free  
LITERATURE.

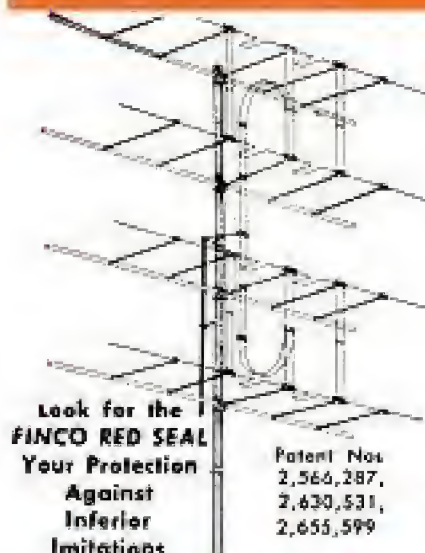

Look for the  
**FINCO RED SEAL**  
Your Protection  
Against  
Inferior  
Imitations

Patent Nos.  
2,566,287,  
2,630,531,  
2,655,599

Perfect Pictures— ALL CHANNELS — UHF and VHF  
Perfect Pictures— TESTED AND PROVED RIGHT HERE  
IN TOWN — IT'S THE BEST!  
Perfect Pictures— ONE TRANSMISSION LINE,  
NO SWITCHING!  
Perfect Pictures— ALL YEAR 'ROUND — WEATHERPROOF,  
ALUMINUM CONSTRUCTION!

**THE FINNEY COMPANY** Dept. PM-2 • 4612 St. Clair Ave. • Cleveland 3, Ohio

Enjoy the Fascinating Story  
of the Horseless Carriage in

Popular Mechanics  
**AUTO ALBUM**

The most intriguing book about the automobile ever printed. It's terrific, fast, fascinating and informative. From the very first gasolines-powered buggy to the cars of today and the atomic cars of the future. The first cars — the men who made them — the scrambled start and the development of the fabulous auto industry — the story of auto racing — the growth of the Nation's highways. 166 thrilling action pictures — all-time cars — racing cars — early auto advertising — automobile accidents. Full roll of names of more than 2000 autos made in the U.S. included. Great gift book. Cloth bound, only \$3.00 by mail. Money back if not pleased. Paper covered edition \$1.00 at newsstands.

POPULAR MECHANICS PRESS, Dept. PM14  
200 East Ontario Street Chicago 11, Illinois



166  
Illustrations



Do a Real Professional-Like Job  
Yourself and SAVE

**HOW to PAINT**  
With Brush and Spray

Covers All Painting Methods and  
Materials

You can do professional-like painting and finishing jobs yourself and save about two-thirds of the cost. Sam Brown, noted craft authority, makes it so easy for you in his book: **HOW TO PAINT WITH BRUSH AND SPRAY**. Order your copy now and enjoy this tremendous saving. It covers exterior painting, wall and interior decorating, furniture finishing, concrete painting — every use of painting with brush, spray gun, roller and other methods. Tells what finish is best, what materials to use, etc. No previous experience needed. Fully illustrated. Order by mail. Only \$2.50. Money back if not pleased.

POPULAR MECHANICS PRESS, Dept. PM18  
200 E. ONTARIO ST., CHICAGO 11, ILL.



OWN A...  
**PLYMOUTH?**

**FIX IT YOURSELF!**

Popular Mechanics Magazine has just published a new Owners Manual covering all 1941 to 1952 models of Plymouth cars. So accurate mechanics use it . . . so simple a woman can understand it.



Save money on your Plymouth repairs. Prevent trouble. Enjoy care-free driving. Increase trade-in value. Avoid major repairs by fixing minor troubles before they get serious. Get sparkling performance at all times. Has 472 pages, more than 350 photos, diagrams, tables, charts, breakdown drawings, plus clear, non-technical directions that make all repairs simple as ABC. Written by Ed Packer with assistance of Chrysler Corporation. Shows you how to diagnose Plymouth troubles by feel, sound, sight, smell and performance. Simple trouble shooting. Permanent repairs. Emergency repairs. Plus, "How to get value from garages."

**MONEY BACK IF IT DOESN'T SAVE MORE THAN IT COSTS!**

One minor repair will save the cost ten times over. Read it. Then you decide. If you don't see that you'll save more than the cost, send it back for refund. **SEND NO MONEY.** Send postcard. Ask for PLYMOUTH Manual, Postman will deliver C.O.D. for \$2.50 plus postage. Or, save postage by sending \$3.00 with order. Send today. Save its cost on your next repair.

POPULAR MECHANICS PRESS  
200 E. ONTARIO DEPT. 18 CHICAGO 11, ILLINOIS

# IT'S DYNAMIC!



## NOW ANYONE CAN WELD FOR PLEASURE OR PROFIT

Enjoy countless hours at home, making beautiful wrought iron furniture and metal knick-knacks. Build or repair all metal equipment around the home, garage and garden. Do professional type work in a matter of minutes with the Dynamic Transformer 110 V. AC Arc Welder. Complete as illustrated—\$38.50 f. o. b. factory. Order NOW and receive \$8.00 twin carbon torch FREE. Write for details.

### DYNAMIC WELDER CO.

Dept. D2-E—1808 So. Federal St., Chicago 16, Ill.

# FORD Owners SAVE MONEY



Learn How to Make Your Ford Run Better . . . Last Longer . . . and Save Hundreds of Dollars!

Get this book, written especially for you, without any taking of risk and get more out of your car. Mail coupon for **MANUAL FOR FORD OWNERS** today. When the book comes, skip through the pages and see how your investment in one of America's most popular automobiles can be even a better investment than you thought. If you don't agree, send the book back and you'll get your money back.

### A Popular Mechanics Book Written Just for You

Not a re-hash of service manuals. A complete new Popular Mechanics book written for the Ford owner by an outstanding automotive authority with the full cooperation of Ford engineers and service directors. It will save you money on repairs and service; make your Ford last longer; give you safe, economical and trouble-free motoring. And this is true whether you take your Ford to a regular service station or service it at home.

### Prevents Trouble, Cuts Down on Repair Bills

Nothing like this manual anywhere. It covers all phases of operation, service and maintenance. It has entire chapters on the individual parts of your Ford—battery, ignition, starter, generator, regulator, lighting, fuel system, engine, lubrication, gasoline qualities, cooling systems, transmission, differential, rear axle, brakes, wheel alignment, tire care, body maintenance, trouble shooting on the road, etc. It covers your Ford, new and older models, step by step—bumper to bumper—showing you how parts operate; what can go wrong; how repairs and adjustments should be made and how to avoid all types of trouble.

### Money Back if Not Satisfied

Mail the coupon today. Send only \$3.50 or you can pay postman. Money-back guarantee protects you.

### Official, Authoritative, Practical Information

Written by C. E. Packer, formerly service school instructor and auto show lecturer for automobile manufacturers. Member Society of Automotive Engineers, Special Services Editor of Automobile Digest, contributor to leading magazines, author of some of the biggest selling books on Automotive subjects.

### Entire Chapters on Fordomatic and Overdrive

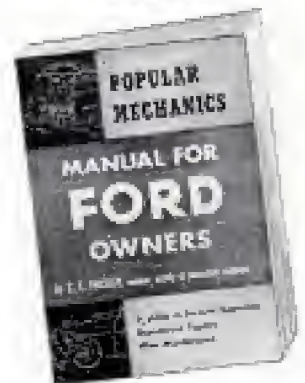

### 304 Pages. Hundreds of How-To-Do-It Illustrations and Diagrams

The entire book follows Popular Mechanics famous easy-to-read and easy-to-understand style. While primarily intended for the Ford owner, to help him get more out of his car at lower cost, it can be worth its weight in gold to the auto mechanic and service station operator who works, not only on Fords, but on all other makes as well, to which the information in the book can be easily applied.

Make Money SELLING Eshelman Tractors and doing GARDEN WORK



## ESHELMAN ROTARY TILLER

ONLY \$99.95 Turns virgin ground into a garden bed in one operation. Replaces plowing, discing, and mudding. Works on wet earth. Also 1 to 8 H.P. POWER MOWERS & RIDING TRACTORS from \$89. Free Catalog. Write:

ESHELMAN CO., Dept. T-52  
119 Light St., Balto. 2, Md.  
332 N. Michigan Ave., Chicago 1, Ill.  
7070 Hollywood Blvd., Los Angeles 28, Cal.

Say You Saw It in Popular Mechanics

## PROOF! Toilet Tissue Makes Ideal Oil Filter Refill... Costs Only 10¢

Install Retlif Adapter Plates in YOUR CAR oil filter and you can use ordinary toilet paper roll for the filter element! Laboratory tests, thousands of motorists, proved conclusively that toilet paper cleans dirty motor oil faster and better than popular makes of filter elements! And costs only 10¢! Now get these advantages with Retlif Adapter Plates. Easily installed. Write today for facts, proof, descriptive literature.

**RETLIF CORPORATION, Dept. 124**  
915 N. Highland Ave., Los Angeles 38, Calif.



## Order on this Coupon

POPULAR MECHANICS PRESS, Dept. MF-2  
200 E. Ontario St., Chicago 11, Ill.

Send Manual for Ford Owners at once. If not satisfactory I will return it within 7 days and you will refund full purchase price.

Remittance for \$3.50 enclosed.  Send C.O.D.

Name \_\_\_\_\_

Address \_\_\_\_\_

City \_\_\_\_\_ State \_\_\_\_\_



## Thrill your child with this drop-leaf desk and bookcase!

get complete detail drawings, photograph and directions in

### FREE PATTERN KIT 305

—along with the picture-packed booklet, "Enchanting Homes of Western Pines." Write for it to Western Pine Association, Dept. 305-N, Yeon Building, Portland 4, Oregon.

## the Western Pines

- \* IDAHO WHITE PINE
- \* PONDEROSA PINE
- \* SUGAR PINE

This desk — scaled to a child's proportions — is just like a grown-up's with pigeonholes, pencil racks, drawer, shelves and cabinet. And the mellow woods of the Western Pines\* lend their own special charm to the simple New England design.

It costs so little to build this desk with the woods of the Western Pines. You'll find that they cut clean and accurately with hand or machine tools and take all finishes well.

Ask your local lumber dealer for the woods of the Western Pines — he'll be glad to give you an estimate!

Only \$6 for the LIFE of your Car . Truck . or Tractor 

## Get a MOTALOY Ring & Valve Job While You Drive - for only \$6!

DO IT YOURSELF . . . This proven way . . .

- \* INCREASES GAS MILEAGE
- \* RAISES ENGINE COMPRESSION
- \* STOPS COSTLY OIL BURNING

No work to do. No equipment to buy. Just drop Motaloy tabs in your fuel tank. That's all! Scientifically compounded tablets made of nine metals start immediate action to improve engine performance . . . saves you real money.

### 1954 MODEL CARS

Stop trouble in new cars before it starts and increase engine life. Motaloy helps retain factory compression and performance thousands of miles longer. Proven in over 263,400 cars — ask your mechanic!

MOTALOY IS GUARANTEED — IT WORKS. OR YOUR MONEY BACK!

ORDER TODAY! MAIL COUPON RIGHT NOW!

ROBERT E. OLSON CO., INC.  
Rm. 417, South Texas Bldg.,  
San Antonio, Texas

I enclose \$6. Please rush me passenger-car size Motaloy prepaid. (no C.O.D.'s please). Please send me free literature!

Name \_\_\_\_\_

Address \_\_\_\_\_

City \_\_\_\_\_ State \_\_\_\_\_

### HERE'S HOW AMAZING MOTALOY WORKS

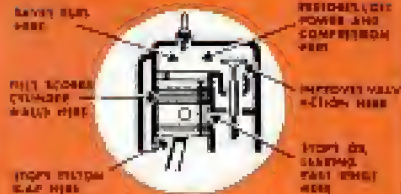

As you drive, Motaloy tabs create a metallic "dust". This passes to combustion chambers where heat creates a carbon-releasing action. Then Motaloy actually replaces pistons, rings, cylinders and valves. This is an anti-friction plating that gives a smoother, more powerful, quieter engine.

### READ THESE LETTER EXCERPTS FROM OUR FILES

- INDEPENDENT LABORATORY, TEXAS: "Performance tests show by use of Motaloy, oil consumption was reduced; compression definitely increased." D.W.C.
- OFFICIAL STATE AGENCY, FLORIDA: "Remarkable improvement in compression, smoothness and quietness since using Motaloy." D.H.R.
- MECHANIC, STATE HIGHWAY DEPT.: "By plating Motaloy in gas tank, noticed improvement in compression and gas mileage; decrease in oil consumption." J.B.S.

Available in 3 sizes. \$6 size for vehicles making more than 8 miles per gallon.



# MOTALOY

REG. U.S. PAT. OFF.

ROBERT E. OLSON CO., Inc.

Rm. 417 So. Texas Bldg., San Antonio, Texas

DISTRIBUTOR TERRITORIES AVAILABLE

**WAR SURPLUS** AND OTHER **BARGAINS** SAVE UP TO 90%

**PRECISION GROUND SQUARES**

Production engineer's Squares. Accuracy guaranteed. Mid. by Wright & Moore, Sheffield, Eng. Square blades hardened & tempered. Individually packed in wood box. Brand NEW. Precision of original cost. 2"-\$2.25, 3"-\$2.50, 4"-\$2.75, 5"-\$3, 6"-\$3.25, 8"-\$4.25, 10"-\$4.25, 12"-\$4.25

**OLDAK DIAL INDICATOR**

Finest Quality. Made to AGD standards except in Range. Continuous or balanced production as required. All parts interchangeable. Made in England. Square available. Totally enclosed case. Detachable contact point with hard steel ball. Model AL318. Reading .001 in.—range 1.000 in. Wt. 2 oz. Only **\$16.95**

**LOW VOLTAGE CIRCUIT TESTER**

Made for U.S. Ordnance. Self-contained device makes complete & rapid check of generator battery circuit. Will check out any 6 or 12 volt system. Garage, mechanic, track fleet owners, boat & marine mechanics. Guaranteed perfect. Shop. Wt. 20 lbs. Approx. GOVT. COST \$175. NEW, complete with steel carrying case & instruction book, WHILE THEY LAST—**\$29.75**

**D. C. GENERATORS—\$14.95**

All these generators will weld plate steel or better. Can be used as combination welder & light plant. Generators like New. Pl. Perfect. 200 Amps. 28 Volts, 2500 to 4500 RPM, Wt. 33 lbs. Approx. Govt. Cost \$350, Now **\$14.95**. Electric Auto-Lite. 200 Amps. 24 Volt. 2500 RPM. Dandy arc welder. Wt. 53 lbs. Approx. Govt. Cost \$450. NEW—**\$20**. Hi Jack & Heinz. Rated 300 Amps. 30 Volts, Wt. 60 lbs. Approx. Govt. Cost \$450. Guaranteed perfect **\$23.90**

**MAKE YOUR OWN ARC WELDER.** Package consists of 1 NEW Auto-Lite J3 generator, 1 plant toggle switch, 1 voltage regulator, wiring diagram chart showing conversion of Aircraft Generator to Arc Welder. SPECIAL—**\$29.50**

**SENSITIVE ALTIMETER IN 10 FT. INCREMENTS** 0 to 35,000 ft. inches of Mercury. Tested and inspected in our own instrument lab. Guaranteed perfect. Ready to install. **\$12.95.**

**NEW IMPROVED MODEL MAUSER- TYPE**

**PRECISION 1/1000" VERNIER CALIPERS**

Quick, handy, accurate. 5" Vernier Calipers. Glass hand-ends, lapped measuring surfaces. Fine engraved scales—1/1000" & 1/10 mm for inside, outside & depth measurements. Friction thumb release. Larger capacity. 2 gth adjustments. Reg. \$25. Now only **\$8.95.** Leather case \$1 extra.

**MICROMETERS** Chrome plated, precision engineered, carefully tooling to give long life. All new 0-1" cap. \$2.25 ea., 1-2" cap. **\$3.50.**

Send 25c for big catalog. Bargains for everyone. Check, Money Order or Cash. 25c deposit on C.O.D. orders. Prices F.O.B. Culver City, Calif. Unless otherwise stated.

**AIRBORNE SALES CO., INC.** Dept PM254  
8501 Stellar Dr., Culver City, Cal.

SAY YOU SAW IT IN POPULAR MECHANICS

**Every tooth in every blade digs the soil like a spade**

**Works as you walk!**

40 Rotating hoe points and 6 cultivator teeth do the job 10 times faster than hoe and rake. Makes gardening easier—more fun—better crops. For extra fine seed beds use—

**RO-HO GARDENER**

Weeds—Hoes  
Mulches  
Cultivates

Easy as mowing a lawn. Kills weeds and mulches soil. Write for Free Folder.

**ROWE MFG. COMPANY**  
1867 Adams St., Galveston, Tex.



**Three of a kind**



There's nothing similar about three books we're bringing out currently except the important fact that they deal with specialized fields and they're done by experts in those fields.

**OLD RAILROAD LORE**

Railroad fans and lovers of Americana alike will hail *Popular Mechanics' Railroad Album*, the story of the iron horse in America. John O'Connell, a lifelong student of railroad history, tells the story in words and pictures—from the first railway in 1826 to the train of tomorrow! Here also is the story of the railroad tycoons . . . the good and bad about Jay Gould, Cornelius Vanderbilt, Edward H. Harriman, Andrew Carnegie, Henry Flagler and others. Those who liked our *Auto Album* and *Aviation Album* will want this third book in our series of American picture histories. It's only \$3.

**OLD AUTOMOBILES**

A treat for those whose true love is the lore of old automobiles will be *How to Restore Antique and Classic Cars* (\$2.95). Here is the first practical how-to-do-it information on the fine art of restoring ancient auto relics to factory finish and running condition, whether it be a 1904 Reo or a 1937 boat-tailed Packard roadster. Hobbyists throughout the country have set down their secrets of restoration for various chapters of this book, while the editors of Popular Mechanics Press have provided other practical tips on getting old motors into smooth-running shape and finishing chassis and bodies to original condition. Whether you've picked up an old Model T or an early Rolls-Royce, this book can help you and save you money.

**OLD-FASHIONED FUN**

The enthusiasm for homemade fun continues right in the face of TV, 3-D and all the other distractions of modern life. So we foresee a wide interest in the *Family Book of Sports and Games*, which is just about the most complete book of fun for all ages that we have ever seen. Here are all the outdoor and rainy-day indoor games for children, plus party games and stunts for adults, plus card games and board games of every description, plus rules and strategy for such games as golf, tennis, badminton, croquet, touch football and hundreds of others. The book was compiled by Helen Joseph of the North Shore Country Day School, and should be a favorite with teachers and librarians as well as being indispensable for the home library. It's well worth \$2.95.

Any of these books can be yours by just stopping at your favorite book store. Or send check or money order to

**POPULAR MECHANICS PRESS**

200 East Ontario Street \* Chicago 11, Illinois



# CUT-TO-FIT HOMES CUT BUILDING COSTS

CHOICE OF 57 DESIGNS

ORDER NOW

SAVE UP TO 1/3

Build your own home and save the builders' profit—plus savings in lumber and labor with Sterling Ready-Cut-Homes. Anyone can assemble with simple, easy to follow plans furnished. Every house complete with all lumber, roofing, nails, glass, hardware, paint, doors and windows marked ready to erect. Freight paid. Complete building plans ready for filing at low cost. Sold separately if desired. Write today!

PRICED FROM \$2150 up  
Five Easy Payment Plans

INTERNATIONAL MILL AND TIMBER CO.  
DEPT. P.M. 24 BAY CITY, MICHIGAN

Send 25c for NEW COLOR CATALOG



## JOINT AND SHARPEN ALL SAWS

SAVE TIME AND \$\$\$

Sensational new Super Filer joints and sharpens both hand and circular saws 6" to 10" with all teeth the correct height, depth, pitch and level. Easy to use—when file hits hardened steel roller, teeth are finished. Saw runs true and smooth with no side pull. Complete with special 8" file \$9.95 ppd. FREE FOLDER.

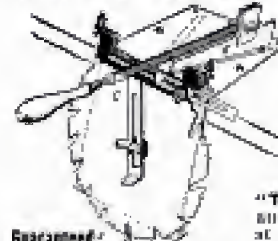

Hand Saw Jointer and Filer, separate . . . \$2.95 ppd.

"TRU-CIRCLE" saw set automatically sets teeth at 10° or more \$2.95.

A. D. MCBURNEY, 5908 Hollywood Blvd., Hollywood 28, Calif., Dept. A-38

## 20 "SEE THRU" DRAWERS!

LOWEST COST — HANDIEST STORAGE

MODEL J-20 . . . . . \$7.95  
Useful in every shop, job, home, office, etc. For nails, T.Y. or ignition work. KEEPS SMALL ITEMS HANDY. No other cabinet can compare in price, construction, strength. "SEE-THRU" durable plastic drawers can't spill, accidentally. PROOF welded steel cabinet. Drawers 5 1/2" L x 2 1/2" W x 1 1/2" H. Divide into 2 or 4 LENGTHWISE or CROSSWISE compartments. Stent removable, restorable. Money back if not satisfied within 10 days. Free catalog on other sizes.

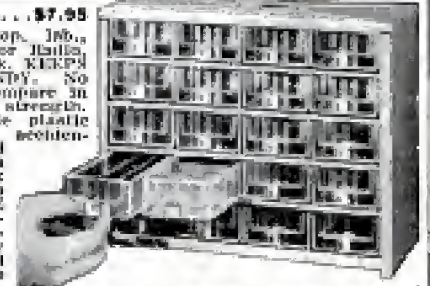

J-24, 24 drawers 5 9.95  
J-32, 32 drawers 12.95  
J-64, 64 drawers 24.95

Contents always fully visible, clean, dustproof, organized and orderly indexed.

MFG. BY AXBO-MILS, INC., 818 E. MARKET, AKRON 5, O.

## BATTERIES! — START

—a factory at home and re-cast junk batteries into new; latest achievement. We supply complete instructions and everything needed. Large daily profits!

BATTERY LABORATORIES, Dept. PM, Minneapolis 4, Minn.



## PARTS FOR MILITARY TRUCKS

and JEEPS 4 & 6 WHEEL DRIVE. WRITE FOR PARTS CATALOG STATING MAKES

**American AUTO PARTS CO., INC.**  
1830 LOCUST—DEPT. PM  
KANSAS CITY, MISSOURI

## THE BEST IN PLIERS? CHAN NEL LOCK

CHAMPION DeARMENT TOOL CO., MEADVILLE, PA.

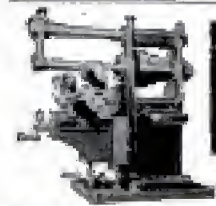

**BUILD YOUR OWN MACHINE TOOLS CASTINGS—DRAWINGS**

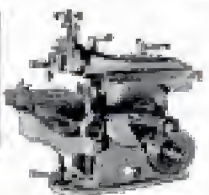

Catalog with complete construction drawings of this No. 2 Bench Miller or six inch crank shaper 25 cents per set post-paid or send one dollar for drawings of shaper, three millers and three lathes. Refund on castings order.  
FOOTATUCK CORPORATION, 100 Sammis Pl., Stratford, Conn.

## The SPEEDY STITCHER

Sews quick and strong, making new or repairing all sorts of leather and canvas articles — boots, shoes, coats, gloves, belts, saddles, golf bags, etc. Football, basketball, skating, hunting, fishing, camping bags, train bags, barbag, etc.



Each stitcher comes ready to use with a reel of waxed thread and 3 needles, assorted sizes. Needles are carried in handle. A handy tool for home or on hunting, fishing or camping trips.

Price Postage prepaid \$1.00.  
**LYMAN BRADFORD CO.**  
Box No. 201 KINGSTON, MASS.

## AUTOMATIC RETOOTHER

MAKES NEW PROFITS

Cut new teeth in 50 seconds in any size 4 to 16 points. Old teeth fall off as chips. Easy to operate. A perfect job.

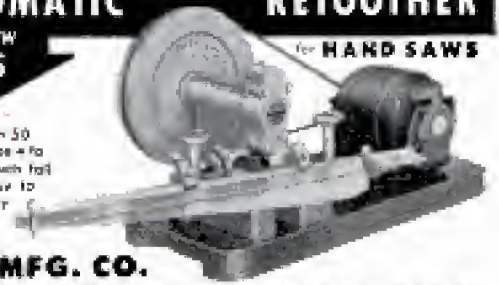

**BURR MFG. CO.**  
8933X VENICE BLVD. LOS ANGELES 34, CALIFORNIA

## AIROLLERS roll your boat ashore on a cushion of air!

Airollers — almost frictionless, large canvas-rubber lined cylinders are inflated to a low pressure by mouth. Rolls even heaviest boats over rocks or soft sand with no damage to hull or paint.

Standard Airoller . . . boats to 1200 lbs. . . . . \$15.00 ea.  
Airoller Jr. . . . boats to 400 lbs. . . . . 9.00 ea.

At Your Dealers, or Write for Descriptive Folder  
**the AIROLLER Co.**  
29 BROAD STREET  
GUILFORD, CONN.



ONE ATTACHMENT FREE

with Viking  
**GARDEN  
TRACTORS**

PATENTED  
ENGINE-  
IN-WHEEL  
DESIGN

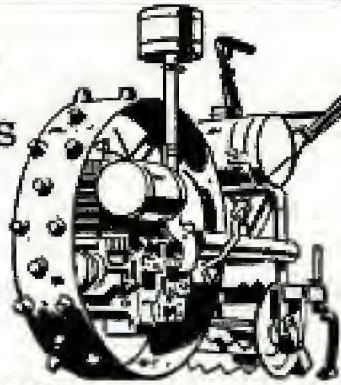

**SAVE UP TO \$37.50**

For a limited time only, we offer absolutely free, your choice of 6 basic attachments (value up to \$37.50) if you order your garden tractor early—help us avoid the last-minute rush.

**VIKING GARDEN TRACTORS** have been known for quality for 30 years by farmers, nurserymen, gardeners, 17 work-saving attachments, easy credit terms, prompt shipment, 30 day money-back guarantee, 1-year parts warranty.

**TWO-WHEEL MODELS** up to 3.6 H.P. for walking or riding, 4-speed forward and reverse gear. Popular, budget-priced **SUB-URBANITE** (engine-in-wheel design) cultivates 12 in. rows, gives amazing new ease of handling, freedom from fatigue. **WRITE TODAY** for prices, colorful new catalog, plus details of free attachment offer.



**TERMS AS LOW AS \$10 PER MONTH**

**American Farm Mach. Co. Dept. F-104**  
1060 33rd Ave. S. E., Minneapolis, Minn.  
43 Church St., Pawtucket, R. I.

**BUILD YOUR OWN POWER TOOLS—GIL-BILT**

**Exclusive GIL-BILT Build-It-Yourself Features**

- No machining—built easily with hand tools only
- No blueprint reading—step-by-step pictorial plans, full scale patterns, actual photographs
- Sturdy wood, aluminum and steel construction
- Capacity and performance of commercial saws setting for \$60 and up
- Proved performance. Nationally advertised and sold for 6 years. Satisfied customers around the world.

**PARTS  
KITS**

**PLANS  
only  
\$1.00  
EACH  
POSTPAID**

**GIL-BILT 10-in. TILT/ARBOR SAW**

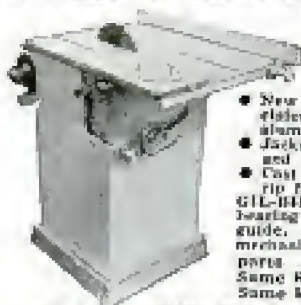

- 22x28 in. table, 15 1/2 in. overhang in front of blade
- 18 in. blade cuts 3 1/2 in. deep, tilts full 45 degrees
- Floor model 34" high, table always stays level

- New Depature ball bearing arbor, 3/4" protrusion that turned down for 5/8" bore blades, sharp, housing, sloped ready to run.
- Jackscrew and 4 1/2 in. dia. handwheel lowers and raises blade
- Cast aluminum miter gauge and self-aligning rip fence guide

**GIL-BILT Metal Parts Kit** includes Plans, ball bearing arbor, miter gauge and bar, rip fence guide, dado insert, lock knobs, jackscrew mechanism and handwheel, and all other metal parts (less blade).....\$22.95  
Same Kit with 10" Combination Blade \$25.95  
Same Kit with 8" Combination Blade \$24.95

**GIL-BILT 12-INCH BAND SAW**



- Cuts to center of 24 inch circle
- Handles stock up to 6 inches thick
- 18x18 inch table tilts 45 degrees
- Lower wheel and drive pulley run on sealed New Depature Ball Bearings. Upper wheel runs on two 1 1/2" bore roller bearings

- Upper wheel housing and tilt mechanism of cast aluminum, completely assembled
- Upper and lower blade guides. Each has ball thrust bearing, self-lub bronze jaws
- Rigid cast aluminum wheels fully machined ready-to-install, heavy rubber tires
- Uses standard 18 inch blades up to 3/4 in. wide
- Fully enclosed mechanism for utmost safety

**GIL-BILT Metal Parts Kit** includes Plans, rubber tires, aluminum wheels, 3/4 in. blade, ball bearing spacers, tilt mechanism, blade guides, table tilt segments, and all other metal parts.....\$23.95

Return kits in 10 days for refund if not satisfied. For shipments up to \$50 value, add 5%; over \$50 add 10%. Amount in excess of actual postage will be refunded. Order kit now, or order Plans at \$1.00 each, and kit later less cost of plans. Write for FREE Catalog.

**ALSO AVAILABLE  
Plans & Parts  
Kits for 18-in.  
Band Saw, Belt  
Sander, 8-in.  
Tilt-Table Saw**

**GILLIOM POWER TOOLS**

P. O. Box 1-108, Lambert Field  
St. Louis 24, Missouri



**Powerful, Pocket-  
Sized Hacksaw!**

**FITS ANY 1/2-INCH DRILL**

The **ROTO B-T** hacksaw is portable, powerful, pocket-sized. Saws wood, plastic, steel and sheet metal, pipe, plaster board, Celotex. Ideal for scroll work. Full 1/2-inch chip clearance. Weighs only 11 oz. Fits up for pocket or tool box, with blade protected. Really a "must" for home craftsmen, electricians, carpenters, plumbers, etc. Hurry and get yours at this low price..... **5.95**

**Rotex Co.**

857 W. Davis St.  
Dallas, Texas

IF YOUR DEALER DOESN'T HAVE THE ROTO B-T HACKSAW, SEND CASH, CHECK OR MONEY ORDER FOR IMMEDIATE DELIVERY.

**WORLD'S BEST SMALL TRENCHERS**



Portable **DITCH-WITCH** digs 2" to 6" deep, even ditches to 36" depth in all types of soil. Complete unit—self propelled—outdigs 8 men. Four rugged models.

Write for illustrated literature. **THE CHARLES MACHINE WORKS**  
620 B Street Perry, Oklahoma



**BRONZE FOUNDRY**

**Schools and Home Workshops**

Make your own castings of aluminum, copper, bronze, silver. Foundry sets are available in three sizes including 2400 Deg. F. blast furnaces. \$22.50; \$29.50; and \$42.00. f.o.b. Kansas City. Free Circular.

**KANSAS CITY SPECIALTIES CO.** P. O. Box 6022, Dept. P-2  
KANSAS CITY, MO.

**All About  
TELEVISION**



**How to  
Replace Tubes  
Install Antennas  
Make Adjustments**



**Cut Down Repair Bills  
... Prevent Trouble**

John Derby, well-known TV engineer, tells and shows you how to save money on the servicing and repair of your TV set. He shows you just how you can locate trouble, and in most cases make repairs yourself in the matter of minutes.

**Special Picture Section SHOWS  
You HOW to Locate Trouble**

A special chapter contains actual photos of defective TV pictures. You merely compare the picture on your screen with pictures in the book, find the trouble at once and directions which tell just how to fix it. The very first time you use **All About Television** your savings will exceed the small cost of the book. Order your copy now. Your money back in 7 days if it isn't entirely satisfactory.

**POPULAR MECHANICS PRESS**  
200 E. Ontario St., Chicago 11, Ill.

Send at once my copy of All About Television. Remittance for \$3.00 enclosed. If it isn't entirely satisfactory I may return it in 7 days for a full refund.

NAME \_\_\_\_\_  
ADDRESS \_\_\_\_\_  
CITY \_\_\_\_\_ STATE \_\_\_\_\_  
D Send C.O.D., U.S.A. only. Postage extra.

# EVERY ELECTRIC DRILL A PORTABLE JIG SAW & CIRCULAR SAW!

THESE TWO AMAZING SAWS HAVE THE SAME FEATURES, DO THE SAME WORK AS OTHER SAWS COSTING \$50 & UP!

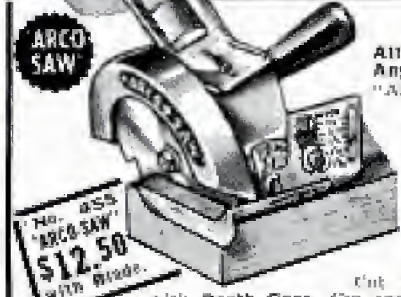

## "ARCO-SAW"

Attaches in One Minute to Any 5/8" Electric Drill. "ARCO-SAW," the only saw attachment to attach these 2x4's in one cut, cuts 8 times faster than hand sawing. Just tighten Safety-Yoke & Clamp around drill and run this powerful saw with one hand. Drill anything from a bookcase to a bathtub!

Cut any depth up to 1 1/2" with Depth Gauge. Cut any angle with Bevel Gauge. Follow a line with Rip Gauge or Visual Guide.

New 5" Safest Blade cuts thru heavy lumber. You'll find "ARCO-SAW" with its tough steel teeth practically indestructible.

BLADES—5" Safest, Rip, Crosscut, or Combination...\$1.75

## "ARCO JIG-SAW"

Does work of Jig, Keyhole, Coping, Rip, Band and Hacksaw! EXCLUSIVE AIR-JET BLOWS AWAY SAWDUST. First for the first time is a Portable Jig Saw that attaches in 1 minute to any 1/2" drill. Cuts intricate patterns, circles—no matter how large—in plywood, wallboard, plastics, etc.—even lumber up to 2x4's! Cuts openings without boring starting hole.

Right Angle Drive makes "ARCO JIG-SAW" easy to handle. Safety Yoke & Clamp give you a vibration-free unit. With Shoe-Plate. Converts to Table Model with

No. 401 "ARCO STAND"—Sturdy casting with clamp...\$2.75

No. 505—Six extra Blades for wood, metals, plastics, etc...\$1.95



AT BETTER HARDWARE STORES EVERYWHERE

No. 500 "ARCO JIG-SAW" \$10.95 complete with blade.

DEALERS Write for nearest jobber.

BUY THE BEST—see your hardware dealer now! If not available, try "ARCO" Tools on our 10-DAY MONEY BACK GUARANTEE. Send us check or M.O. (Postpaid, C.O.D.'s—postage extra)

90-DAY FACTORY GUARANTEE.

**ARROW METAL PRODUCTS CO.** Dept. PM-2, 140 WEST BROADWAY, NEW YORK 13, N. Y.

### MAKE YOUR OWN FOUNTAINS, LAKES, RIVERS, WINDOW DISPLAYS

With New Miniature Water Pump Here's real action for window displays, Xmas tree layouts, or the home job. Pump only 4 1/2" high—1 1/2" wide. Threaded for pipe, or uses 3/8" rubber tubing. 110 A.C. 60 Cycle. 1/250 H.P. 50 gals. per hr. Furnished complete—ready to work—your satisfaction absolutely guaranteed or your money back. **\$9.95**

**MOORE MANUFACTURING COMPANY**  
Swedesboro 15, N. J.

### MACHINISTS-TOOL MAKERS-ETC.

Enhance your tool collection and increase your earning power with 10 VERY USEFUL TOOLS. You build them yourself. They can't be bought anywhere! Real gems, which will help do your work faster, easier, faster and with greater accuracy! Tried and proven successful by the practical men of our trade. Another line more than 20 yrs. of machine shop and designing exp. We have hundreds of testimonials from satisfied machinists. DRAWINGS & COMPLETE INSTRUCTIONS ONLY \$2.00. Money back in 10 days if not satisfied. **PINKHESSEY TOOL DESIGNERS** 2147 So. 76 St., West Allis 14, Wisconsin

MAKE YOUR TOOL CHEST A TREASURE CHEST...

### MAKE MORE MONEY!

Dealers or Representatives Needed for nationally advertised line of Spark Plugs — Oil Filters — Auto Specialties — Liberal Proposition — Full or Part Time — Experience Not Necessary — Write Today

**ENGINE PRODUCTS MFG. CO.**  
3801 E. Beverly Blvd., Dept. 128, Los Angeles 27, Calif.

### BARRON Drill Press TOOLS

FOR WORKSHOP AND INDUSTRIAL USES...

Over 40 precision built woodworking tools and accessories... Hi-Speed Router Bits—Rotary Surface Sanders & Drum Sanders—Safety Shaper Cutters—Oxetail Cutters—Large Auxiliary Metal Tables—All Metal Shaper Fences—Spindle Adapters—Handy Bench Vises. Many other items indispensable for accurate, useful, versatile workshop use. Every tool sold on complete satisfaction or your money back. See your Barron Dealer. Ask for special folder — "24 Extra Uses for Your Drill Press."

Rotary Planer Planes • Habbets Tenons • Panels Routs • Bevels

Only \$8.50 COMPLETE

**BARRON TOOL CO. INC.**  
364 Architects Bldg., Detroit 1, Mich.

FREE Workshop Guide & Catalog

### Our 683rd Advertisement REAL DIESEL ENGINE

**\$3.95**

- for planes, boats, model cars
- 7500 RPM- 1/7 HP; ht. 3 1/2"; wt. 5 oz.
- precision machined for smooth operation

You just can't beat this price for a precision diesel engine! Streamlined, compact, easy to install. Thousands of satisfied users all over the world. Fast delivery if you ORDER TODAY! Sept \$3.95 plus 25¢ postage.

**GOTHAM HOBBY CORP.** Dept. P, 107 E. 126th St. New York 35, N. Y.

### ORDER BY MAIL AND SAVE \$\$\$\$

#### PORTABLE COMPRESSOR UNIT WITH 22 GALLON TANK

1/2 H.P. D.T.S. Only capacitor motor, 110V A.C. Compressor 2" bore, 1 1/2" stroke, piston 1 1/2", splash feed oiling, 1 1/2" x 2 1/2" tank, auto. pressure switch CFM 2.5 at 100 lb. pressure. Check safety valve, air regulator with gauge, filter, 20 ft. air hose, air chuck for inflating tires, 1/2" bolt drive. Ball bearing wheels with 1/2" rubber tires. Shipping weight 90 lbs.

With 1/2 h.p. motor Assembly Unit Yourself and Save \$88.88  
**\$109.50 \$92.95**

Regulator, Gauge, and Filter, sold separately. Price for the 3 items **\$8.95**

### WELLWORTH Compressor Outfit FOR WORKSHOP AND FARM

Both valves finished, bronze bearings, splash lubrication, 1/2" bolt drive, intake muffler and cleaner, 2" hury, 1 1/2" stroke, 2.8 cfm up to 150 lbs. pressure. Need 1/2 h.p. motor or other gas engine. Unit includes: compressor, pressure tank, air gauge, air rount, 20 ft. hose, safety valve, copper wiring with 4 brass flared fittings for connecting compressor to tank, 4 way cross and 2 hoses. **READY TO ASSEMBLE**

M.E. Complete Outfit, wt. 30 lbs. with 1 1/2"x2 1/2" tank... **\$32.45**  
Outfit with 1 1/2"x2 1/2" tank... **\$38.50**  
Compressor only... **\$20.50**  
Unit less compressor wt. 14 lbs... **\$12.45**

### WELLWORTH COMPRESSOR SPECIALS

<b>Model 800</b> As in above unit 2" bore, 1 1/2" stroke, 2.8 cfm up to 150 lbs. Use with 1/2 h.p. motor. <b>\$20.50</b> Ship. wt. 10 lbs.	<b>ALL PRICES F.O.B. Chicago</b> Send for Free Catalog Dept. PM254	<b>Model W7</b> 2 cylinder 2 1/2"x2" 5.10 up to 8.50 cfm up to 150 lbs. Use with 3/4-1-1/2 h.p. motor. Heavy duty compressor. <b>\$59.95</b> Ship. wt. 45 lbs.
---	--	---

**WELLWORTH TRADING CO.**  
1832 S. WABASH AVE. CHICAGO 16, ILL.

**Schupack's Amazing Tool Bargains! All Brand New! Save up to 100%!**

**112 PIECE ASSORTMENT \$3.95**  
FOR ELECTRIC GRINDER  
\$10.00 VALUE - ONLY  
Here's what you get! Assorted Saws, 24 1/2" Mandrels, Drum Sanders, Sanding Blocks, 40 Sanders, Rotary Cutters, Wire Sander Brush, Plastic Brushes, Circular Saw, Buffing Wheel, Grinding Wheel, Rubber Polishing Wheel, Cut-off Wheels, Rubber Cylinder, Mandrels 10 1/2" above last, each!

**Post-Paid**  
Sanding Bars, Sharpening Stone, etc.

**2 CIRCULAR SAWS \$1.50**  
ON 2 MANDRELS - ALL AT ONE LOW PRICE  
17" diameter saws on 1 1/2" Mandrels. For cutting wood, plastic, or soft metal. Order at special "Need Check" or Money Order.

**Post-Paid**

**12 MOUNTED WHEELS \$2.95**  
FOR GRINDING ON PLASTIC, WOOD, SOFT AND HARD METALS. Regular and Value \$8.40.  
12 MTS. WHEELS ON 1 1/2" SHANK... \$3.50  
18 MOUNTED POINTS ON 3/32" SHANK... \$2.50

**Post-Paid**

**2 DRUM SANDERS \$1.50**  
With 12 Bands in Assorted Sizes. 1 1/2" dia. x 1" long on 1/2" arbor with 12 bands  
**ONE DRUM, 1" DIA. x 1" LONG ON 1/2" ARBOR WITH 6 EXTRA SLEEVES \$1.00**

**Post-Paid**

**ADAPTER CHUCK \$1.50**  
With 3 interchangeable collets, opening from 3/32" to 9/16" on 1/2" shaft. Price each only.

**Post-Paid**

**HIGH SPEED DRILLS**

**7 High Speed \$1.00**  
Drills P.P.  
15 Drills \$2.00!  
7 "Populap" sizes—up to 1/4". Brand new. Set 2 1/2". \$4.95

**15 Assorted Drills**  
From 1/16" to 1/2" high speed, and carbon. Set 257  
Only... Post. \$3.95

**12 Assorted Drills**  
High speed & carbon steel. From 1/16" to 1/2". Set 221  
Post. \$3.50

**8 Assorted Drills**  
From 1/16" to 1/2" high speed. Set 222  
Post. \$9.50

**Woodworkers' Drills \$2.00**  
P.P. U.S.A.  
4 drills, from 1/16" to 1/2" with 1/2" shanks. Brand new, popular sizes. Set 214.

**5 Woodworkers' Drills**  
From 1/16" to 1/2". Set 218  
Only... Post. \$3.50

NEW ILLUSTRATED CATALOG 10c

**75 MOUNTED WHEELS & MINIATURE CUTTERS \$4.50**

Regular \$11.00 value. For cutting and grinding on wood, metal or plastic. Includes 20 min. wheels and points on 3/32" shanks; 24 miniature cutters on 3/32" shanks; 25 short shank min. cutters. Will fit all electric drills and hand grinders.

**Post-Paid**

**FLEXIBLE SHAFT - ONLY \$4.95**  
Fits all electric drills & hand power tools. 35 3/4" long. 3/32" dia. inner core of specially woven, high carbon steel wire in flexible steel casing. Will accommodate tool shafts up to 1/4" dia. For lathe, electric drills, etc.

**Post-Paid**

**12 MINIATURE CUTTERS \$1.00**  
FOR CUTTING WOOD, PLASTIC, & METAL. Assorted sizes. 1/2" shank. Post paid. \$1.00  
20 SHORT SHANK MINIATURE CUTTERS... \$1.00

**Post-Paid**

**18 ROTARY CUTTERS \$5.85**  
Value \$13.50  
Illustrated catalog \$1.00  
Assorted sizes either on 1/2" or 3/32" shank. Will fit all hand grinders. Ideal for cutting wood, metal, or plastic. Brand new.

**Post-Paid**

**4 HIGH SPEED SLITTING SAWS \$2.95**  
ONLY  
From 1 1/2" to 3" dia. 1/2" to 1" arbor. For cutting hard and soft metals, wood, or plastic. Ass'td. sizes. A regular \$8.00 value.

**Post-Paid**

SCHUPACK SUPPLY CO., 7331 COTTAGE GROVE AVE., DEPT. M-51 CHICAGO 19, ILL. SEND CHECKS OR M.O. NO C.O.D.'S PLEASE

**BURKS SUPER TURBINE PUMPS LAST LONGER**

**ONLY PUMP WITH LIFE-LOK FEATURE**



Thanks to the LIFE-LOK feature, the BURKS Super Turbine Water System lasts up to 40% longer than any other kind, delivers more gallons per minute and provides "like-new" performance and efficiency when other types would be worn out. It's completely automatic—self-priming.

**FREE BOOK PICTURES PUMP DETAILS**  
Send today for "The Story of Burks"—a 32-page book giving detail drawings, graphs, etc. See why BURKS is finest engineered system... why it delivers more water per hour... why it's the finest water system you can buy. Write to—  
**DECATUR PUMP CO., 61 Elk St., Decatur 70, Ill.**  
SAY YOU SAW IT IN POPULAR MECHANICS

**New! Miracle Wood Drill "SCREW-MATE" DOES 3 JOBS AT ONCE**

Drills shank and pilot holes and counter-sinks on wood or plastic. Automatic stop insures 100% holding power. Drill 40 holes p.m. accurately! High tungsten steel. Fits all 1/2" chucks. Utility Kit. 5 pop. sizes with stand. **\$3.95** Postpaid for only.

**FREE CATALOG "Do-It-Better-Easier Tools"**

**Eagle Products** BOX 84A, MERIDEN, CONN.

**POWER HACKSAW \$55.75**  
LESS MOTOR  
F.O.B. Benton Harbor



\* Rugged cast iron construction. Wt. 56 lbs. bronze bearings. Draw cut. Auto. return lift. Auto. shut-off. Vise swivels 45°. Cap. 4"x4".

Send for full details and name of nearest dealer.

**EXCEL MACHINE TOOLS** Dept. PM-24 BENTON HARBOR, MICHIGAN

**AUTOMATIC AIR COMPRESSOR \$79.00**  
FREE QUART GUN



1/2 HP heavy duty capacitor motor, 115-V. 60 Cy. AC. \$93.50  
X2 Quincy 3 CFM, 100-150 lb. compressor \$20.50  
Furnas automatic adjustable pressure switch \$8.50  
Tank #278, rubber tired wheels and handle \$17.00  
Adjustable pressure regulator and gauge \$6.00  
Moisture filter - \$3.25 V-belt drive \$2.75  
Hose and tire chuck \$2.50 Safety valve \$1.50  
Check valve & copper tubing \$1.75  
Small parts shipped parcel post prepaid at above prices.

Complete 1/2 HP unit assembled, ready to use—Plus Special FREE \$10.00 value Quart External Atomizing Spray Gun with every unit... \$79.00 F.O.B. Chicago  
Save \$10.00 - 1/2 HP outfit knocked down, you assemble, free spray gun, \$12.00 value. \$25.33... \$49.00 F.O.B. Chicago  
Same as above with larger 1 1/2 HP motor—free spray gun, knocked down unit \$79.00 \$2.50  
\$85.50

1 1/2 HP accessories, large 4 CFM compressor, free gun... \$123.50 F.O.B.  
\$25K-100 - 1 HP Motor 15x30 Tank Twin Cylinder 5 CFM Compressor, All Access. You Assemble. Free Gun... \$149.50 F.O.B.

**C. MARSHALL SALES**  
3548 W. Fullerton Ave. Dept. P-2 Chicago 47

**VOLUME BLOWERS FOR HEATING, VENTILATING, EXHAUSTING**

Blowers for forced drafts, heating boosters, exhausters, coolers, dryers and dust collectors, 110 volt A.C., 50/60 cycle motors.

- \*75 CFM Blower, 3 inch wheel... \$10.75
- \*125 CFM Blower, 4 inch wheel... \$14.75
- \*200 CFM Blower, 4 1/2 inch wheel... \$19.50
- 400 CFM Blower, 5 inch wheel... \$32.50
- 600 CFM Blower, 6 inch wheel... \$38.50
- 1000 CFM Blower, 8 inch wheel... \$52.00
- 1500 CFM Blower, 9 inch wheel... \$72.00

\*These blowers with motors shipped Post Paid. Larger sizes are F.O.B.

Write for CIRCULAR: Listing Motors; ALL SIZES: Fans and Air Compressors - ALL SIZES.

**16 TO 1 SPEED REDUCERS**  
For Display Table - Barbecue Spits - Toy Auto Gear Box - Experimental Uses, Etc. Gears Enclosed in Aluminum Housing. Bronze Gear, Hardened Worm, Input Shaft 1/4 in. Output Shaft 3/8 in. Speed Reducer  
2R 181... \$5.95 Post Paid



**WINCH HOISTS FOR GARAGE-SHOP-FARM**

**NEW SURPLUS WINCH HOIST**



Ideal for use in garage, machine shops, boat yards, farms, trucks, etc. Has 7500 lb. lift capacity through a 24 to 1 gear ratio. Has bronze worm gear drive. 18 feet of 3/16" high tensile strength steel cable. Originally made for use at Navy Bomb Hoist. **3250**

**SURPLUS 5 TON HOIST**



A real heavy duty hoist. Mfg. by the Seattle Chain & Wfy. Co. Hand operated. Has 2 speeds - one for rapid lifting and one for heavy duty. Drum size is 3-3/8" wide x 5" dia. at center. Complete with hand brake and crank type handle. A \$100 Value **7350**

**MARK VII - MODEL 1 NAVY SURPLUS HAS MAX. 1500 LB. LIFT**



**PORTABLE GIRAFFE NECK WINCH HOIST**

Originally made for U.S. Navy Barracks of Ordnance at a Bomb Hoist. Has a 21 to 1 gear ratio. 20" tube extension with 3" pulley on the end. 12 ft. of 3/16" steel cable. Handle has a ratchet brake. Ideal for swing about, truck and platform loading. Overall length is 48". **2750**

**MARK VII HOIST**



Same as Mark VII above without the extension tube and with a fast reeler. Has automatic handle brake on the lift. **ONLY 2475**

**PROP PITCH MOTOR**



One of the best all-around heavy duty motors. Does the job of bigger, bulkier more expensive motors and you can operate it on as little as 15 Volts DC. Will handle rotation of heavy beam antenna, boom equipment, etc. Cold weather will not FREEZE it up. Rated at 2 HP but will develop tremendous power through a 10,000 to 1 gear reduction. Easily adapted to AC current by using my standard current converter. **1975**

**UNIVERSAL JOINT**



Rotates with full flexibility from 90 to 180 degree angle. Body is solid bronze. Drive shaft is 28/32" dia" steel. Yoke is ball & socket type. Ideal for use on boats and heavy equipment. **595**

**RIGHT ANGLE DRIVE**



Has direct 1 to 1 ratio through 90° bevel gears. Drive & take-off shafts are 3/8" diameter. Gears are self-lubricating, high speed steel. Ideal for use on power tools, line drives, etc. Size: 2 1/2" x 2 1/2" x 1 1/2". **225**

Many other types Gear Boxes and line drives in stock. See our CATALOG 1

**QUICK STOPS KILL! BE SAFE!!**

**NEW AUTOMOBILE SAFETY BELT**

WILL WITHSTAND A LOAD OF 2000 POUNDS AROUND A HUMAN BODY



Many serious injuries & deaths are caused by being thrown through a windshield or against the dash. The PCA Safety Belt is designed to prevent these tragedies. Made by the Parachute Corp., to withstand terrific stress. Can be installed in any car. Fits all rear seat models. Made of finest Nylon webbing with a chrome plated Airline buckle and metal fittings. Colors: Green, Gray, Maroon. **795**

This belt may save YOUR life or the LIVES OF YOUR LOVED ONES!!! A \$17.50 VALUE

**SAVE UP TO 85% ON WAR SURPLUS**

Here at Palley's we carry the WORLD'S LARGEST supply of special Hydraulic Equipment. Our huge stocks of Hydraulic Cylinders alone feature over 20,000 units in 41 sizes and types. We also stock thousands of accessories such as Hydraulic Pumps, Transmissions, Valves, Tanks, Fittings, Hoses, etc.

**HYDRAULIC CYLINDERS**

No. 29 - Double Action Cylinder Gives 20,000 lbs. lift with a 1500 PSI line pressure, or will give 40,000 lbs. thrust on an intermittent 3000 lb. line pressure. Has a 4" bore, 1-1/2" diameter piston shaft. 18 inch stroke. 20-1/2" length. Ideal for presses, tool, form and other work. Cost Gov't \$395. **295**

**P-1A PESCO GEAR PUMP**



Capacity, 1 1/2 GPM at 1500 RPM at 1500 PSI. Pressure limit is 1500 PSI continuous, with intermittent maximum of 1875 PSI for 15 seconds. Normal operating speed is 3750 RPM with an intermittent maximum speed of 4500 RPM. Ratchet right-hand only. **Now 895**

No. 3 - Double Action Cylinder - Bore is 1", Stroke 1/2". Stroke adjustable from 2-1/2" to 4" with internal sleeve stops. Length overall 8-1/2". Will lift 1500 lbs. continuous - 3000 lbs. intermittent. Will lift or push up to 1100 pounds. **575**

**NEW! PUMP FOOT MOUNT**



Contains 2 first-line, high speed bearings. Mount plate has 4 holes - 2" from the center to center. Has spline shaft one side, key slotted 1/2" shaft on other side. **1050**

No. 46 - Double Action Cylinder. Bore 2-1/4", Shaft 1", Stroke 1-1/2". Length 13-1/4". Lifts 6000 lbs. with 1500 lbs. pressure. **1150**

**Large Bore FOOT MOUNT** - For a pump up to 80 HP. Four mount holes are 2-1/2" center to center. Shaft is 3/4" dia., slotted. **1495**

No. 52 - Double Action Cylinder. Bore is 2-3/8", shaft 1 1/2", stroke 1 1/2", length 26". Gives 6645 lbs. lift with 1500 lbs. line pressure. **2050**

**VICKERS HYDRAULIC TRANSMISSION**



Self-contained, constant torque at all speeds with variable volume, reversible piston pump which supplies piston hydraulic motor. Has 2 3/4" Automatic pressure dash pot for smooth control. Power output RPM - One 1/2" input RPM in both directions. Input RPM 1800 continuous, 4500 intermittent. Ideal for Lathes, Dupli-licator setup on Mills, Conveyors, Small Cars, Drives, etc. **4250**

**HYD. HAND PUMP**

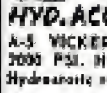

Has operating pressure of 3000 PSI. Capacity of 1.5 cu. inches per complete cycle. Our special price ONLY. **1275**

**4" SPLINE SHAFTS** for input and power take-off on above. Pair \$2.50

**INPUT & TAKE-OFF PLATE ASSEM.** To adapt Trans. to pulley drive. Has 1/2" keyway shaft. 2 first-line, shielded high speed bearings in each unit. Per Set. **\$20.00**

**HYD. ACCUMULATOR**



A-3 VICKERS - Built to stand 3000 PSI. Has lead Hydraulically vent. **2450**

**V-13 - FOUR WAY VALVE** - Pilot from Neutral position. Pressure balanced. Built-in relief valve for limit of cylinder strokes. Open center in **NEW 1750** neutral position. Parts are 3/8" ACTube. **USED 1250**

**SURPLUS RADIO VALUES**

**NOW AVAILABLE FOR FIRST TIME IN 3 YRS. ARMY FIELD PHONE**



A private phone or intercom system. Easy to operate. Reception up to 30 miles. Uses two standard flashlight batteries. Several phones can be used on same line. Set controls ringing generator, leather carrying case & phone. Complete system of 2 generators, 2 phones **3495**

Price for SYSTEM

**NAVY SOUND-POWER PHONE SET**



Used by the Navy for flight deck and gunnery control. An ideal emergency communication system because they require no power supply. Perfect for offices-to-shop, house-to-garage or base, or any point-to-point within 1/2 mile radius. These sets are fully sound powered. A set included 2 phones on chest plate, two headsets, button switches, 35' of cable. **995**

**U.S.A.P. THROAT MICROPHONE**

T-30-C. Consists of 2 microphones on rubber neckpiece. Operates on 100 to and 300 Ohms. A surplus value of \$1.39

**RADIO ANTENNA REEL**



For tuning Beam Antenna. Powered by 1/4HP, 24V, GE motor, engaged to gear reduction only when electrical contact is made. Will operate in either direction. Ideal for auxiliary power take-off. 150 RPM at take-off. May be used for opening and closing doors, etc. Cost Gov't approx. \$125.00. **NEW 875**

**DC METERS VOLTMETERS**

0-30	0-200	0-0-30
0-60	0-480	0-0-50
0-120	0-300	0-0-60
		120-0-120

**495 EACH**

All Voltmeters & Ammeters are NEW and have 2" face (except 0-300 which is Used and has 3" face) Manufactured by Westinghouse, G.E., & Weston.

**NEW AMMETER 0-30 ONLY 495 EA.**

NOTE: External SHUNTS are required on DC AMMETERS.

SHUNTS - with meter . . . \$1.35  
SHUNTS - without meter . . . \$1.65

**1954 Edition of WORLD'S MOST AMAZING BARGAIN CATALOG!**

**320 PAGES - FULLY ILLUSTRATED**

Larger than ever before. Packed with SENSATIONAL VALUES in WAR SURPLUS, FACTORY CLOSE-OUTS and GENERAL MERCHANDISE! Included are thousands of items in Hand & Power Tools; Hydraulic Cylinders, Pumps, Motors, etc.; Hardware; Industrial Tools; Cameras and Photo-Supplies; Outdoor and Sporting Equipment; Microscopes, Binoculars, Telescopes, etc. Foam Rubber, Aircraft Parts, Electrical Motors, Blowers, etc. Gadgets plus many, many more hard-to-find items.



**Only 50¢** Order Your Copy Today! We refund your 50¢ on your first order of \$1.00 or more.

**PALLEY SUPPLY CO.**

7343 E. VERNON AVE. DEPT. PM-2  
LOS ANGELES 58, CALIF.

Order From This Ad. Pay by M.O. or check. P.O.'s accepted from D&B firms. 1/2 deposit with C.O.D.'s. All Prices FOB Los Angeles.

# SOUTH BEND 10"-1" COLLET LATHE

**Top Value**  
for those  
who want  
the best!



Built for exacting industrial work, the South Bend 10"-1" collet lathe satisfies the demands of any craftsman. Its accuracy simplifies precision jobs and permits work of the highest professional quality. This is the perfect tool for shop owners who want accuracy and versatility. Write for literature on the 10"-1" collet lathe and its many attachments. Time payment terms: 10% with order and balance in 12 or 18 months.



Can I get it?  
When? How?

Yes—you can get most any South Bend product immediately from our distributor's stocks in principal cities. Items not stocked, shipped promptly from factory.

Three ways to order:

1. See or telephone nearest distributor.
2. Order by mail from your distributor.
3. If no distributor is nearby, order direct from factory.

South Bend machine tools with accessories may be purchased on convenient terms up to 18 months.

SEND INFORMATION  
CHECKED:

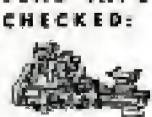

9" and 10"  
BENCH LATHES



10" to 16-24"  
FLOOR LATHES



DRILL  
PRESSES



TOOL  
GRINDERS



1/2" & 1" Collet  
TURRET LATHES



7"  
BENCH SHAPERS

Name \_\_\_\_\_

Company \_\_\_\_\_

Street \_\_\_\_\_

City & State \_\_\_\_\_



Building Better Tools Since 1906 • SOUTH BEND LATHE • South Bend 22, Indiana

# THIS ALADDIN 5-ROOM HOUSE

# \$1995

## FREIGHT PAID

Slightly Higher West of Missouri River



## YOU CAN BUILD THIS ALADDIN READI-CUT HOUSE YOURSELF... and Save Hundreds of Dollars!

Imagine receiving A COMPLETE HOUSE IN ONE SHIPMENT—ready to erect! You get everything needed. The lumber is the finest—every piece THOROUGHLY DRY. And it comes to you the EXACT SIZE needed—cut at the mill by fast, precision machines. No stopping to measure and saw each piece! (You save as much as 30% on labor—18% on waste) and YOU CAN CHOOSE

FROM 99 INDIVIDUAL PLANS—beautiful, modern houses of all sizes and styles. Not only will you save money but you will have the satisfaction of knowing that Aladdin Houses have withstood the test of time during the past 46 years. Aladdin's thousands of satisfied customers are your guarantee of honest value. We will send you names and addresses on request.

### BEAT THE HIGH COST OF BUILDING!



With carpenters getting up to \$24 a day think how much you can save by building your own Aladdin house! Carpentry work runs from 300 to 1200 hours. Even if you

hire help you save because most of the expensive, time-consuming labor (measuring and cutting) has been done at the mill. No wonder the cost of an Aladdin house often compares favorably WITH PRE-WAR COSTS! Drawings and instructions are easy to follow and cover everything from foundation up. More than half the Aladdin houses sold have been erected by buyers themselves!

### NO DEALERS' OR AGENTS' PROFITS IN ALADDIN PRICES—BUY DIRECT!



**GOOD HOUSES NEVER GROW OLD—ALADDIN HOUSES ARE NOT PREFABRICATED**



**QUALITY: ALL EXPOSED LUMBER IS GUARANTEED TO BE CLEAR AND KNOTLESS**

### WHAT READI-CUT MEANS

The picture at the right shows how each piece of Aladdin lumber is cut to EXACT size at the mill—mitred and bevelled for perfect fit. Aladdin houses are designed to meet the most exacting building standards in both construction and materials.

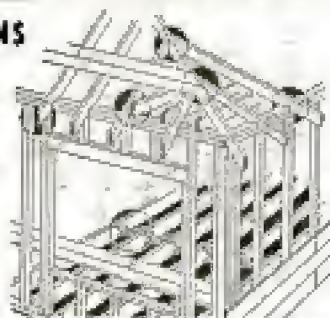

**IMMEDIATE DELIVERY**

### WHAT YOU GET WHEN YOU BUY AN ALADDIN HOUSE

- ALL THE LUMBER accurately cut to fit, marked and numbered ready to erect practically without the use of a saw.
- SIDING • WINDOWS • MOULDINGS • GLASS
- MILLWORK • DOORS • HARDWARE • NAILS
- FLOORING • TRIM • PAINT • ROOFING
- COMPLETE DRAWINGS & INSTRUCTIONS

## EXCITING NEW HOME DESIGNS FOR 1954!

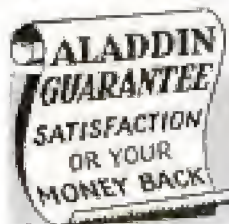

SEE THEM IN THE LATEST BOOK OF ALADDIN HOMES →

**THE ALADDIN CO.**  
BAY CITY, MICHIGAN

Est. 48 Years



Why did you change to Camels,  
WILLIAM HOLDEN?



"With so many people smoking Camels, I figured they must be good! So I tried them — found their cool mildness and swell flavor suit my taste to a T! You ought to try Camels yourself!"

WILLIAM HOLDEN, star of "Forever Female", is another on the big list of Hollywood personalities who prefer America's most popular cigarette, Camel!



"Good Smoking"  
William Holden

for Mildness and Flavor

**CAMELS** AGREE WITH MORE PEOPLE  
THAN ANY OTHER CIGARETTE!

Make your own  
30-day Camel  
mildness test —  
you'll see how well  
Camels' mildness  
and flavor suit you.



You, too, rate the cigarette that rates *best* with the *most* smokers! After all, Camels' costly tobaccos *assure* you a cool, cool mildness, a rich, exclusive flavor that other brands can't match! So *try* Camels — today. Smoke only Camels for 30 days. Let your own sense of good taste tell you why Camels' flavor and mildness agree with more people than *any* other cigarette!

R. J. REYNOLDS TOBACCO CO.  
WINSTON-SALEM, N. C.

Copyrighted material